

Alumline

Technical brochure for heating and cooling ceiling modules



Alumline: for optimal comfort and energy saving whatever the season

With the reduction of CO₂ emissions and tightening of thermal regulations, the construction industry plays an important role in the fight against global warming. Of course, these changes affect thermal insulation and building design, but also heating and cooling systems. This is why the position of the heat exchanger and the operating temperatures, for example, play a critical role in reducing energy consumption.

SPECIAL FEATURES OF ALUMLINE

Due to a short response time to temperature changes, energy efficiency and architectural freedom, Zehnder Alumline enables functional solutions for heating and cooling.

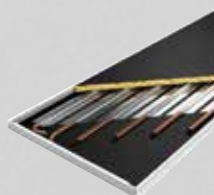

PAGE 4 – 7

MOUNTING AND INSTALLATION

The installation stage is made easier, due to a flexible system and professional support from Zehnder.



PAGE 8 – 15



TECHNICAL SPECIFICATION

- Calculation of pressure loss and minimum mass flow
- Heating and cooling performance
- Technical specification



Special features of Alumline

Due to a short response time to temperature changes, energy efficiency and architectural freedom, Zehnder Alumline enables functional solutions for heating and cooling.

Areas of application

- Offices and meeting rooms
- Schools
- Nurseries
- Hospitals

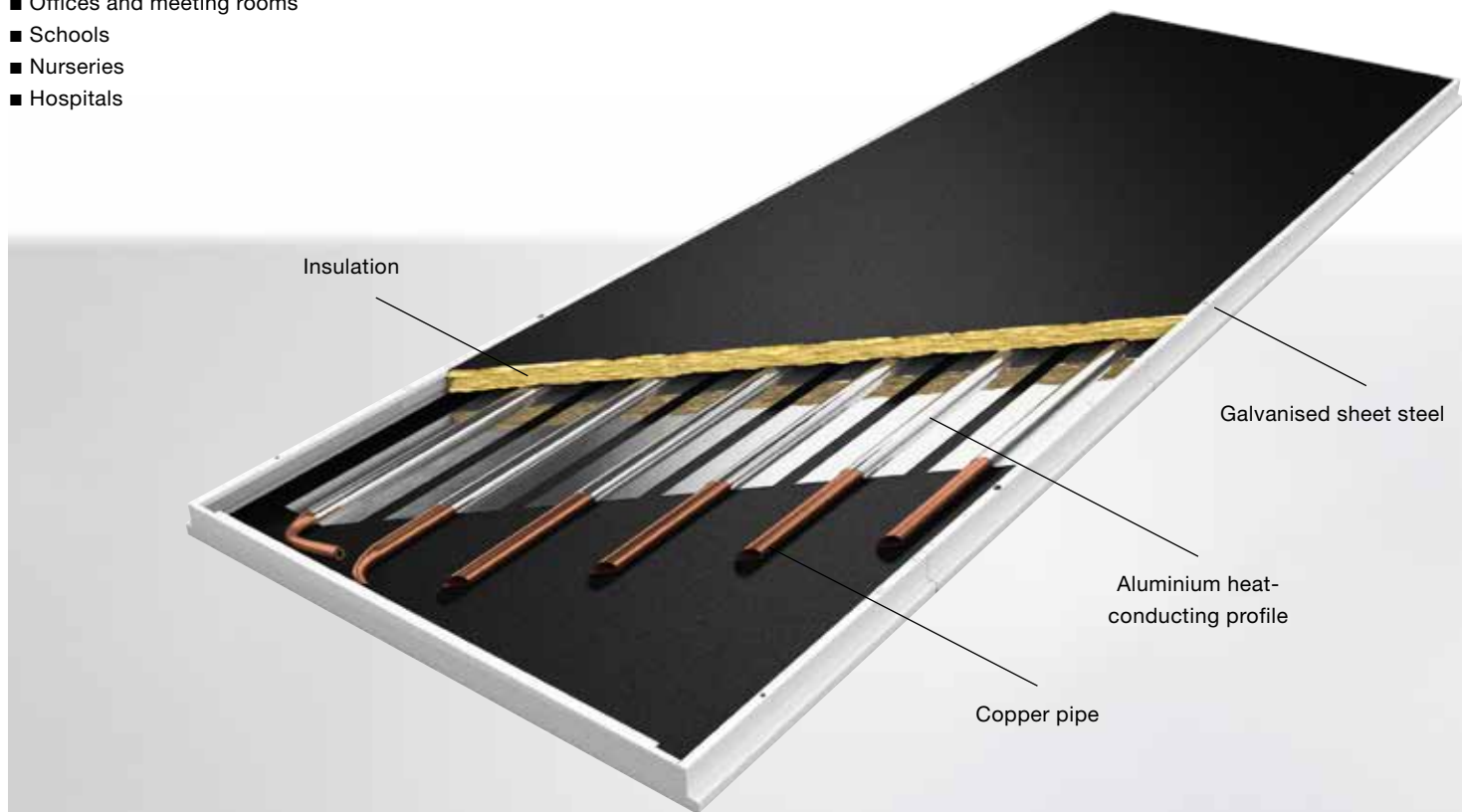

+ ADVANTAGE

- Energy saving thanks to a short system response time to temperature changes
- Operating temperatures perfectly suitable for low temperature system
- Can be installed in the suspended ceiling or as a freely suspended installation
- Simple installation: lightweight, delivered ready to install, simple hydraulic connection
- Integrated sound insulation (optional)
- The high-quality paint on the surface of the radiant ceiling panels guarantees the system's long service life
- Lightweight and long service life due to the aluminium profiles

The radiant panel system is activated by aluminium heat-conducting profiles and a D-shape meandering copper pipe.



Round tube



D-pipe

The special D-shape of the copper pipe increases the surface area for thermal transfer to the aluminium heat-conducting profile and to the steel sheet. Moreover, the D-pipe ensures a turbulent flow even with a low mass flow, which enables optimal thermal transfer.

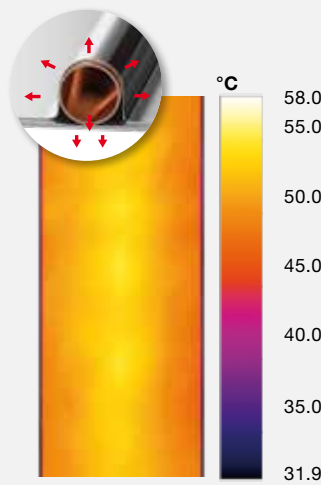

Heat flow characteristics of conventional round tube

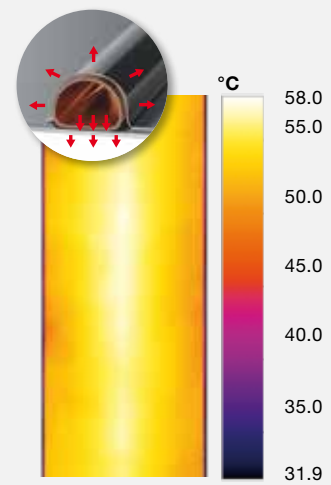

D-pipe heat flow characteristics



Maximum value: 53.2 °C
Average value: 47.5 °C



Maximum value: 55.8 °C
Average value: 49.5 °C

The thermograph shows that the D-pipe produces a more even and more pronounced thermal transfer than a conventional 12 mm round tube. This is achieved thanks to better encapsulation of the pipe in the aluminium profile and on account of the large contact area of the pipe on the heating and cooling module. With the combination of the D-pipes and the aluminium profiles, a performance increase of 5% is possible depending on heat flow and application.

Together with Zehnder's expertise in the development and production of radiant ceiling panels for heating and cooling, these special properties enable very powerful systems that can easily be integrated into all spatial configurations.

The ideal system for every project

The surface of the Zehnder Alumline radiant ceiling panels has a high-quality powder coating and can be delivered in a smooth or perforated finish. The modules are available in the standard white colour (RAL 9016); further RAL colours available on request.

Connecting clips for sail surfaces



Sound-absorbing version, perforated plate

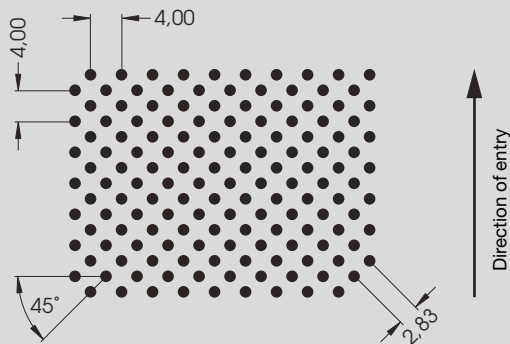

The Zehnder Alumline radiant ceiling panels can be perforated to provide optimised sound absorption. Sound waves pass through the perforations and are absorbed by the specially developed sound insulation. With sails, the sound waves are also absorbed by means of reverberation on the top of the product. This significantly reduces noise and the associated vibrations, especially in open-plan offices, call centres, schools, etc. We will be happy to provide you with the acoustic calculation data on request.

Hole diameter	1.5 mm
Open cross section	22%

Variants	Ceiling sail perforation 1.5 mm Open cross section 22%	Ceiling sail perforation 1.5 mm Open cross section 22%	Ceiling sail perforation 1.5 mm Open cross section 22%	Smooth ceiling sail	Smooth ceiling sail	Smooth ceiling sail	Closed ceiling perforation 1.5 mm Open cross section 22%	Closed ceiling perforation 1.5 mm Open cross section 22%	Closed ceiling perforation 1.5 mm Open cross section 22%
	with mineral wool in LDPE foil	with mineral wool in LDPE foil	with mineral wool in LDPE foil	with mineral wool in LDPE foil	with mineral wool in LDPE foil	with mineral wool in LDPE foil	with mineral wool in LDPE foil	with mineral wool in LDPE foil	with mineral wool in LDPE foil
Activation	6 parallel pipes	4 parallel pipes	None	6 parallel pipes	4 parallel pipes	None	6 parallel pipes	4 parallel pipes	None
Sound absorption coefficient α_w (EN 11654)	1	1	1	0.45	0.4	0.4	0.55	0.85	1

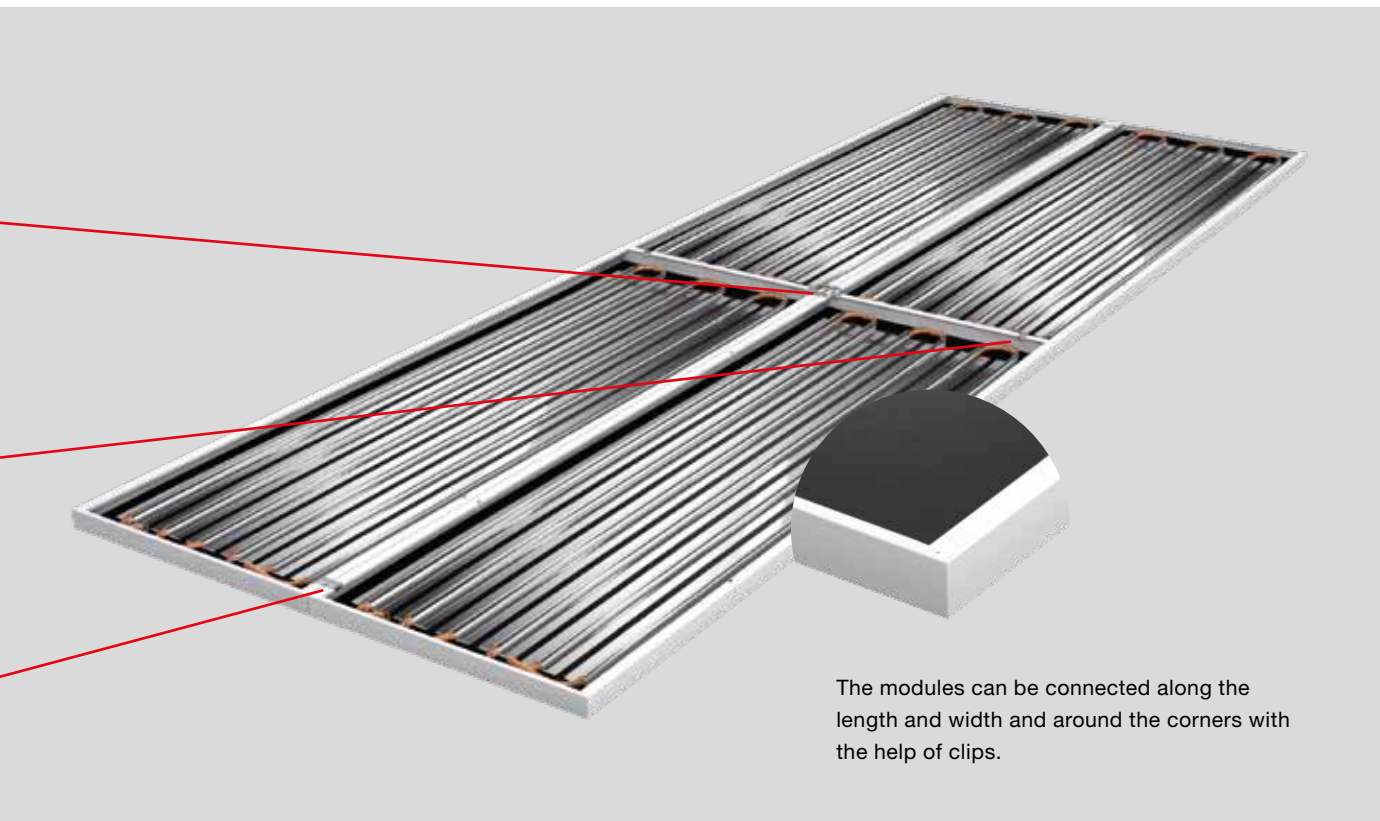

The modules can be connected along the length and width and around the corners with the help of clips.

Anti-flec technology for lay-in modules (longer than 1,500 mm)

Not only for using Zehnder Alumline lay-in modules in high temperatures.

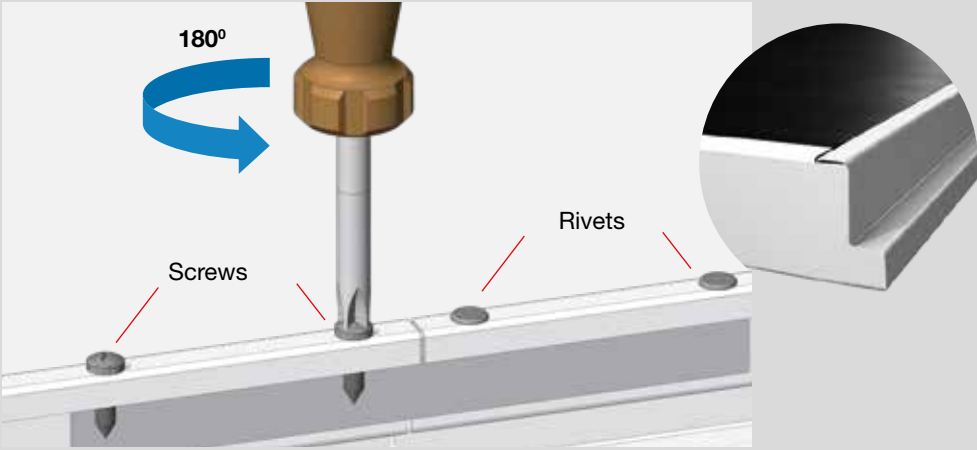

The Zehnder Alumline lay-in modules for grid ceilings are produced from a length of 1,500 mm with anti-flec technology. This ensures an even contact surface on the ceiling grid, even when heating.

After laying the modules in the grid, the anti-flec profiles are loosened in the ceiling grid by opening the pair of screws.

Flexible installation options

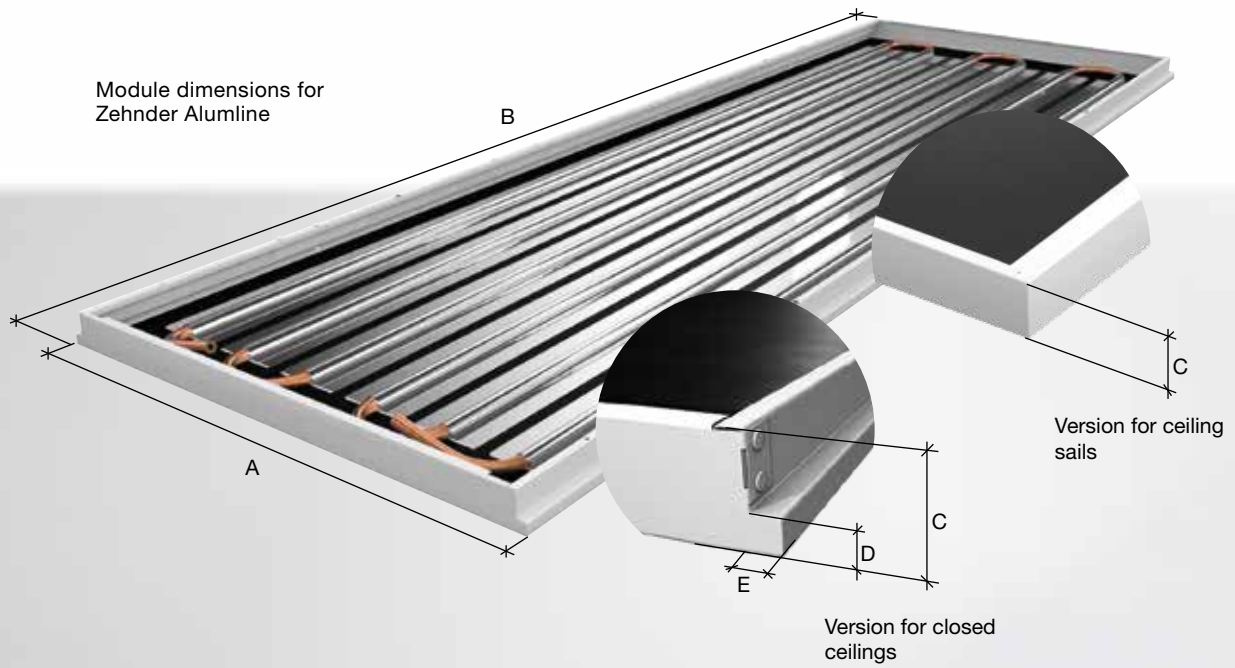

Dimension	Description	Closed ceiling	Ceiling sails
Module 600		Dimension in mm	Dimension in mm
A	Overall width	595	600
B	Overall length	592 - 2,992	600 - 3,000
C	Total height	40	40
D	Height of the supporting edge	14	-
E	Width of the supporting edge	10	-

Modules for closed ceilings

The Zehnder Alumline radiant ceiling panels are perfect for integration into all types of lay-in ceilings, especially into traditional grid ceilings (600 x 600 mm or 600 x 1,200 mm), which are often used in schools, hospitals, nurseries, retirement homes and offices. The sections come in five standard sizes. Special dimensions available on request.

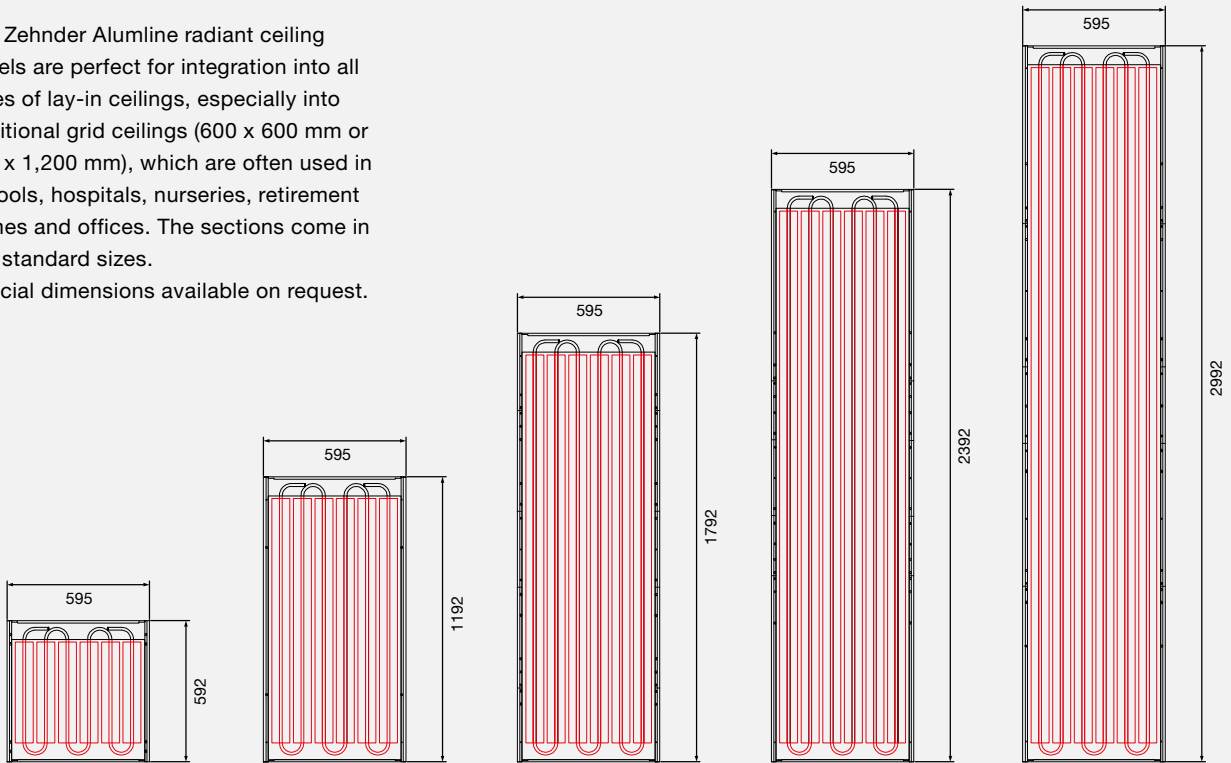

Modules for ceiling sails

The Zehnder Alumline radiant ceiling panels can also be installed freely suspended. In this case, the edges are straight for aesthetic reasons. The individual sail modules can be installed very quickly and easily next to or behind each other. They also provide significant sound insulation. With their discrete design, they can be delivered on request in the RAL colour of your choice and integrated into any architectural style. This version is available in five standard sizes. Special dimensions available on request.

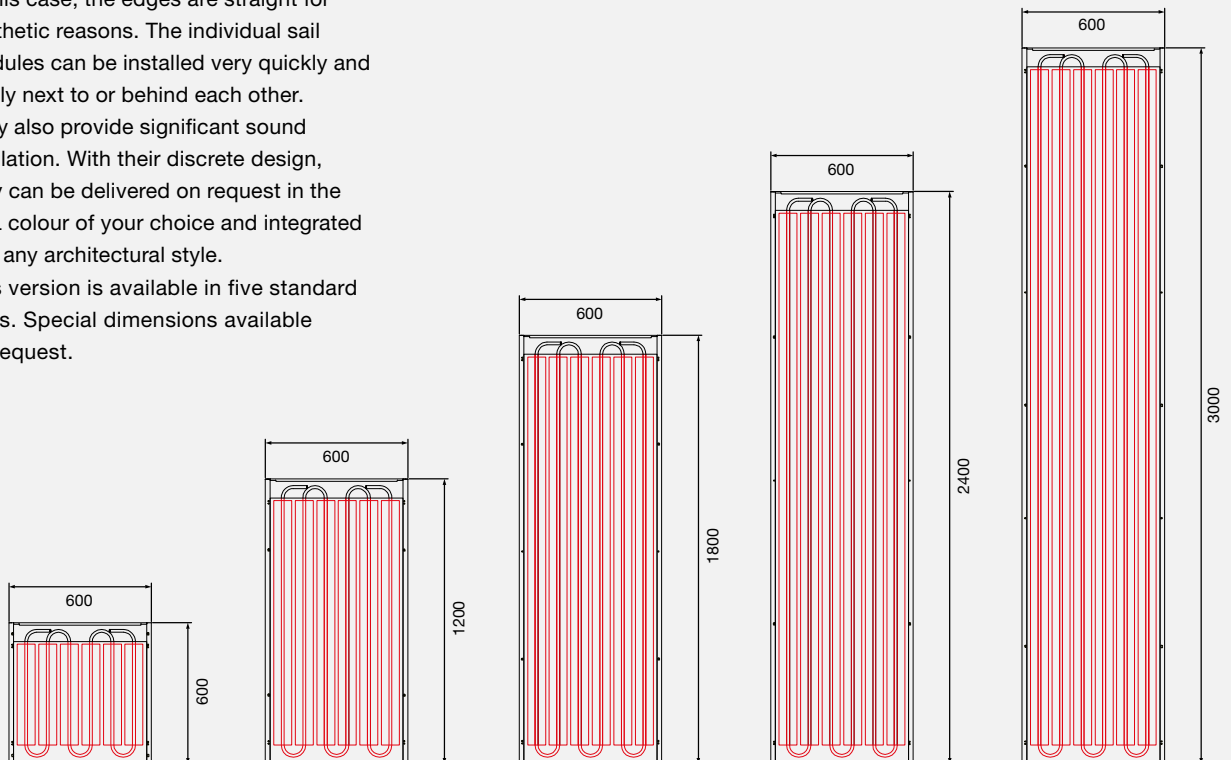

Suspension system for lay-in module and sail

Standard lay-in modules

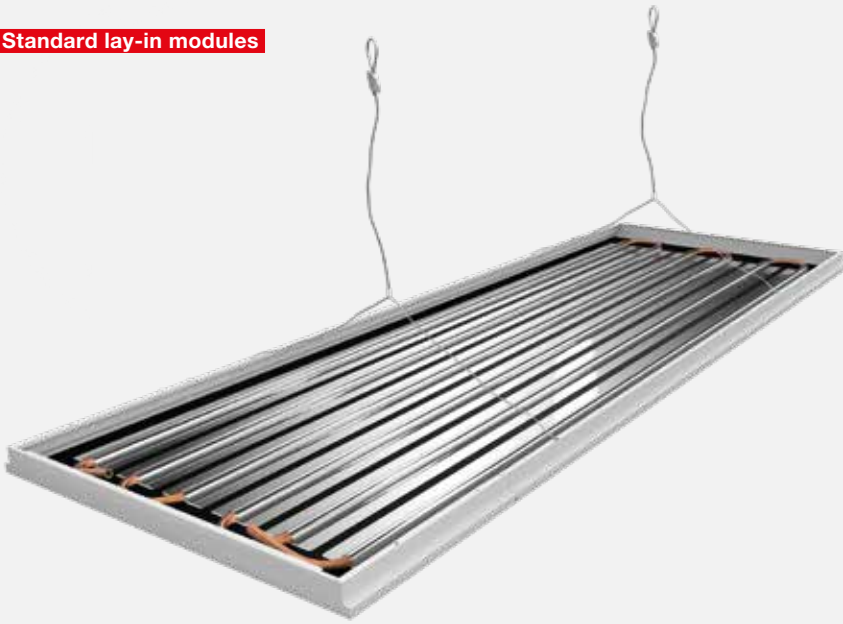

Cross anchor

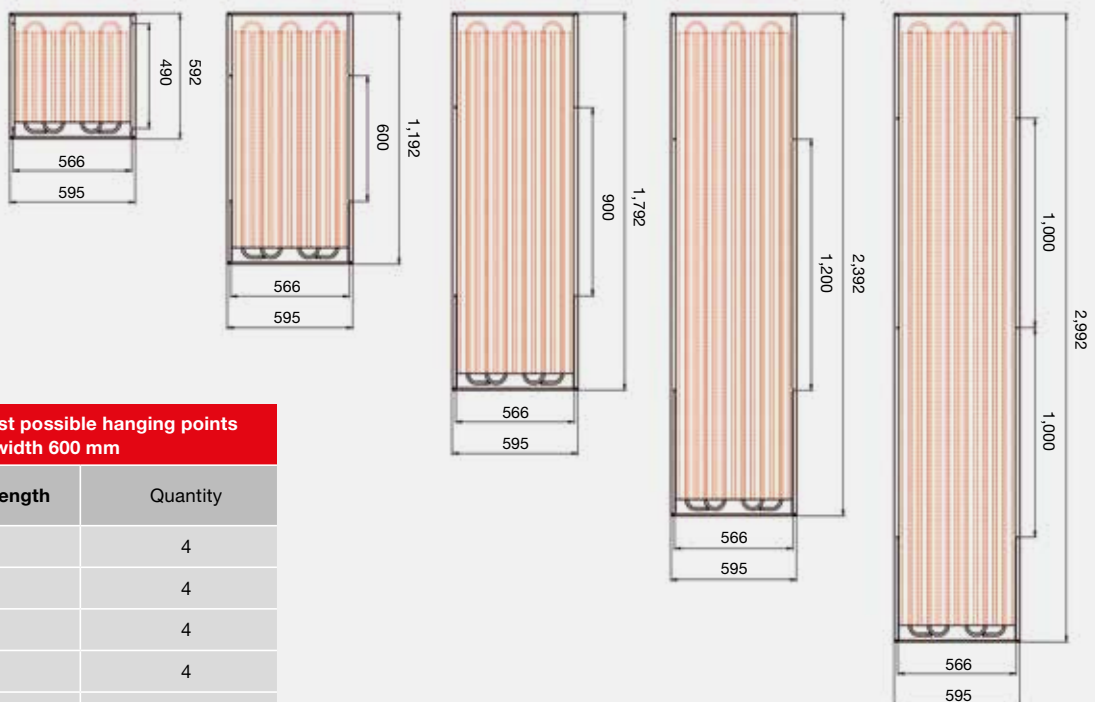

Number of highest possible hanging points
Nominal overall width 600 mm

Nominal overall length	Quantity
600 mm	4
1,200 mm	4
1,800 mm	4
2,400 mm	4
3,000 mm	6

Suspension system using multi-clips (sails)

The multi-clip is pushed into the lateral edge of the module.
The suspension points can therefore be varied.
*See the areas specified at the bottom of the drawings.



Multi-clip with carabiner

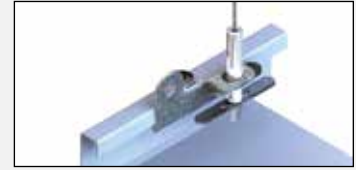

Multi-clip with wire cable and fine adjustment

Standard sail



Long hole with fine adjustment



Cross anchor



The suspension system must be at a right angle to the module on all planes.

Fine adjustments enable the module to be aligned exactly, which makes installation easier.

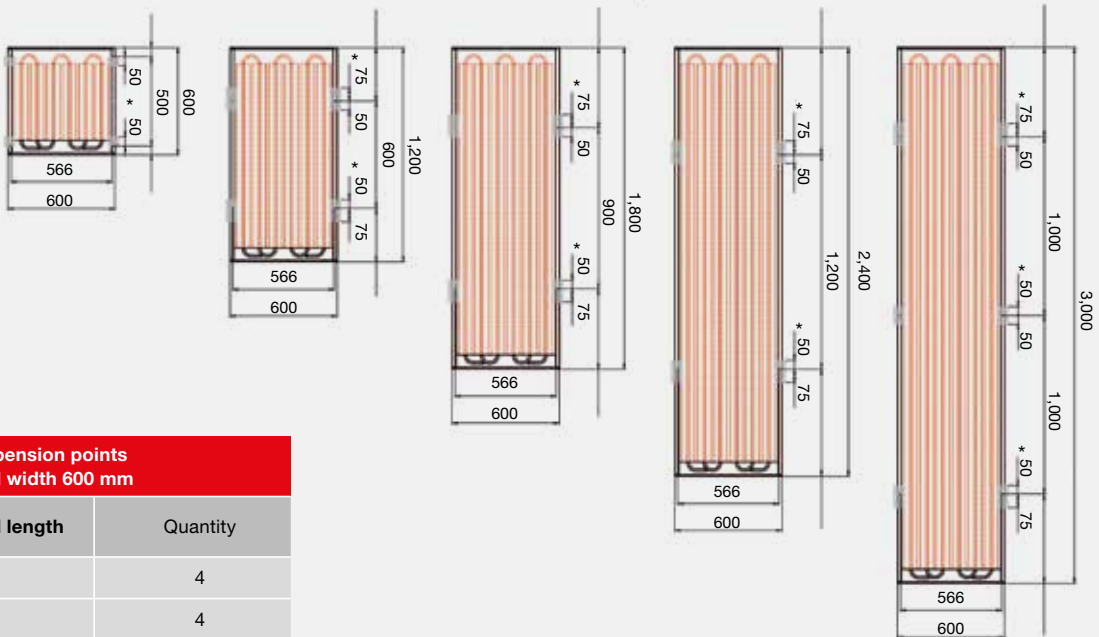

Number of suspension points Nominal overall width 600 mm

Nominal overall length	Quantity
600 mm	4
1,200 mm	4
1,800 mm	4
2,400 mm	4
3,000 mm	6

Special solutions

The Zehnder Alumline ceiling modules are extremely adaptable: in addition to the wide standard range, there are also a number of special solutions available. Therefore, whatever the room and whatever the project, we have exactly what you need.

LARGE SAILS

Zehnder Alumline large sails are available in widths up to 1,250 mm and lengths up to 3,600 mm. The modules are fixed to threaded bars or wire cable suspensions with suspension axes.



LARGE SAILS THAT CAN BE HINGED DOWN

Zehnder holding brackets also make it possible to individually hinge down large sails connected in series. The suspensions are adapted for the specific project on site. Holding brackets can be combined with standard ceiling accessories currently on the market.

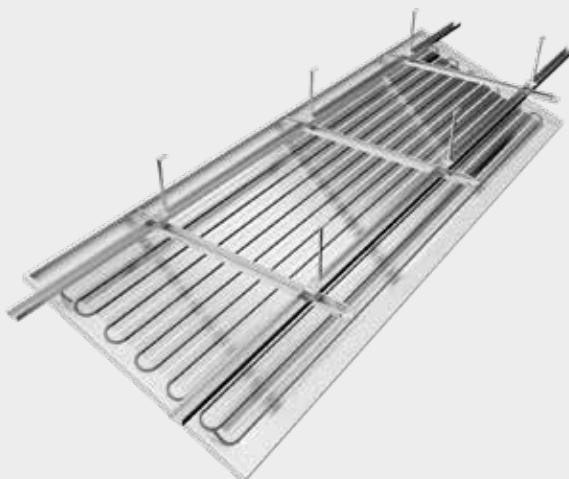

LARGE SAILS THAT CAN BE HINGED DOWN - AS A SYSTEM

Zehnder offers various special solutions for large sails that can be hinged down.



SAILS WITH HOOK SUSPENSION

Zehnder hook suspensions make it possible to take down sails individually. During installation they are characterised by easy handling for suspension and ability to align the modules next to each other.



SPECIAL SOLUTIONS TAILORED TO CUSTOMER REQUIREMENTS

We supply individual customer solutions – cut-outs, special perforations and special shapes. We will find a solution by working together with you. The figure shows cut-outs for lights.

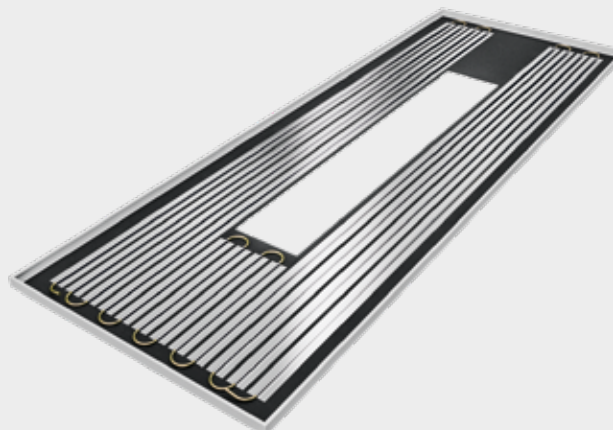

Connection technology

6 parallel pipes

The Zehnder Alumline radiant ceiling panels can be installed as strips up to a maximum of 9 metres in length. In this case, the front-facing radiant ceiling panels have 2 serpentine circuits with hydraulic couplings on both sides of the panels, which enable a series connection.

Two modules next to each other with same-end connection.



Special solution



Cut-outs can be made in the Zehnder radiant ceiling panels in order to integrate external wall grilles, projectors, fire alarms, lights and other equipment.

Three modules behind each other with same-end connection.

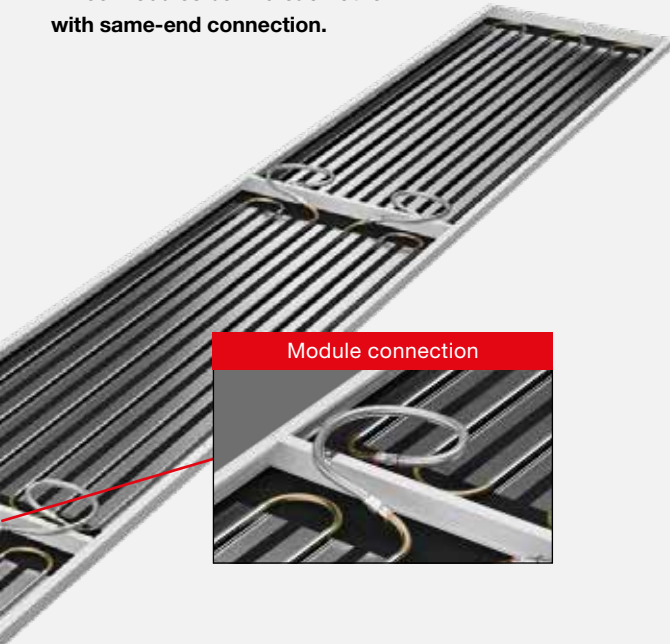

Module connection

Two modules behind each other with centre connection.

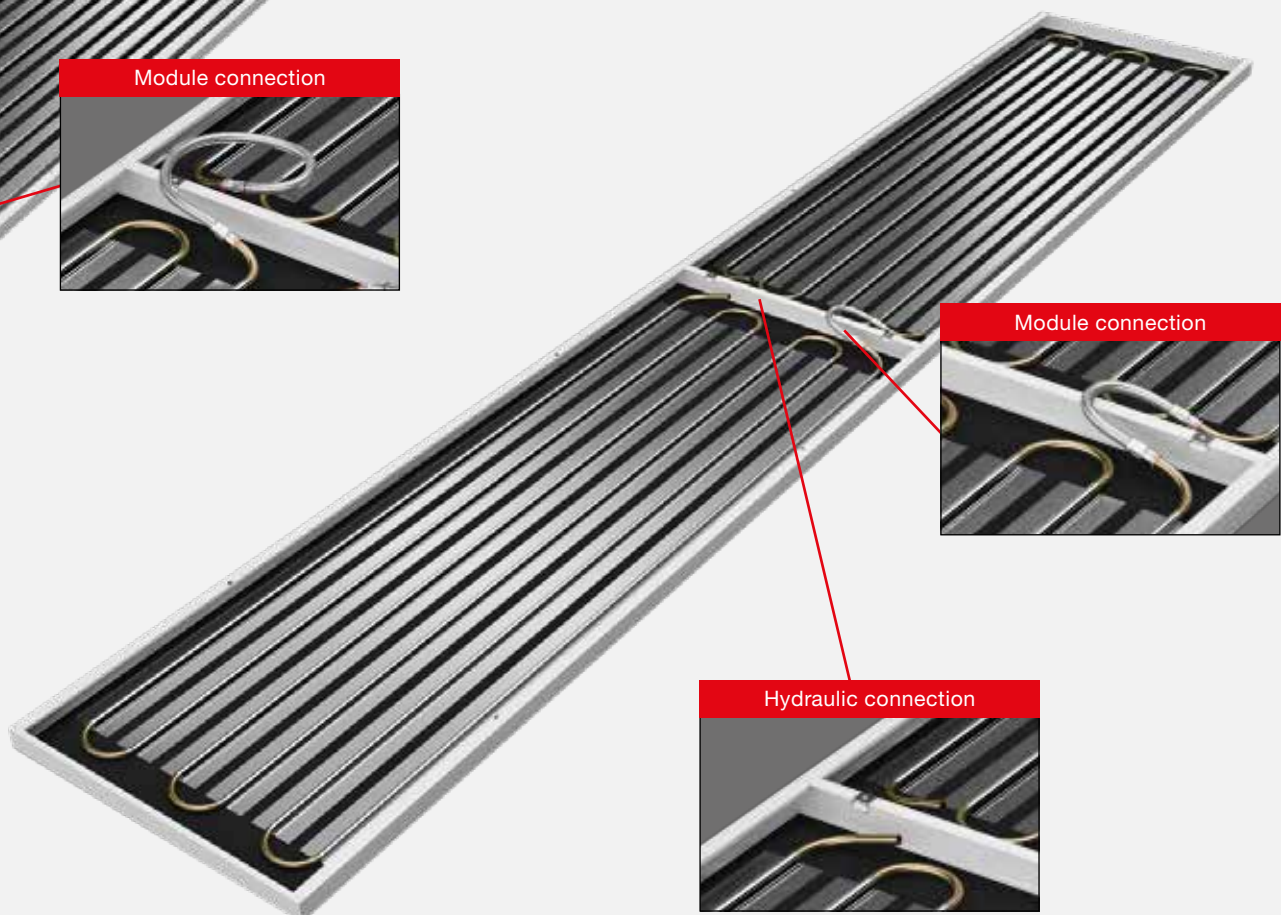

Module connection

Hydraulic connection

Minimum mass flow

To maintain the outputs shown in the tables on pages 18/19 and 20/21, a turbulent flow must be ensured within the pipes in the radiant panel system. This minimum mass flow depends on the lowest system temperature. When heating, this corresponds to the return temperature. When cooling or in a combined cooling/heating mode, this corresponds to the cold water flow temperature. If the minimum mass flow per pipe is not achieved, this can result in a drop in performance of around 15%.

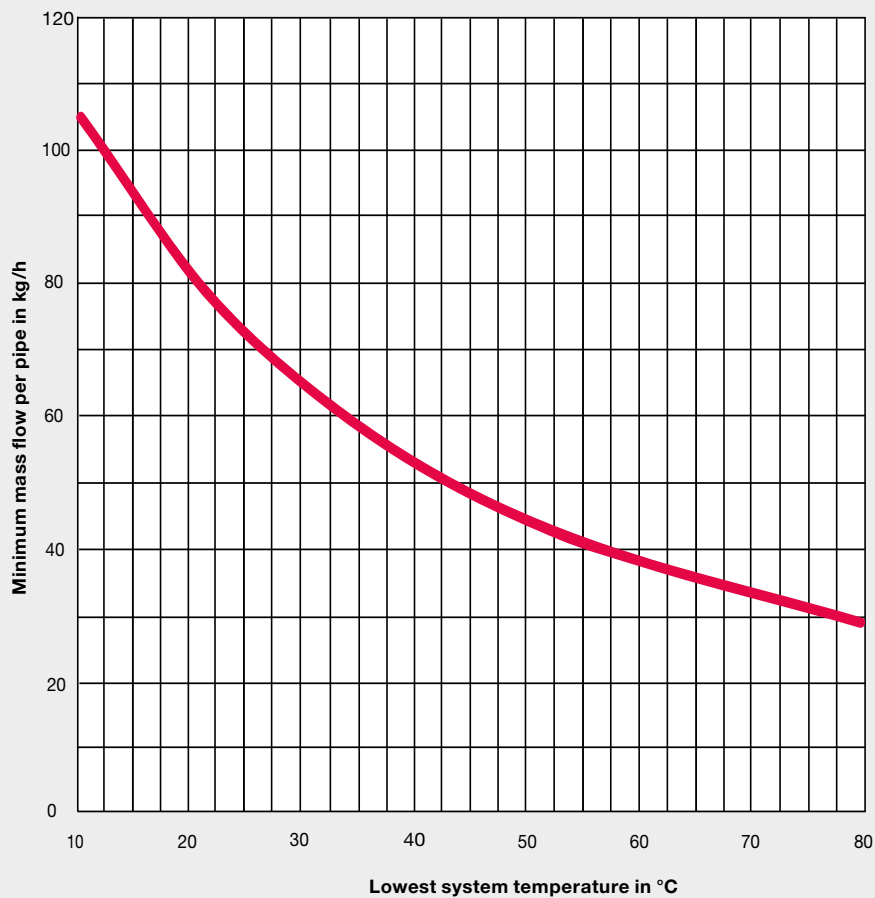

Pressure loss calculation

The pressure loss, depending on the module size and mass flow, is shown in the diagram. The maximum permitted flow speed is 0.5 m/s.

Pressure loss graph 6 parallel pipes

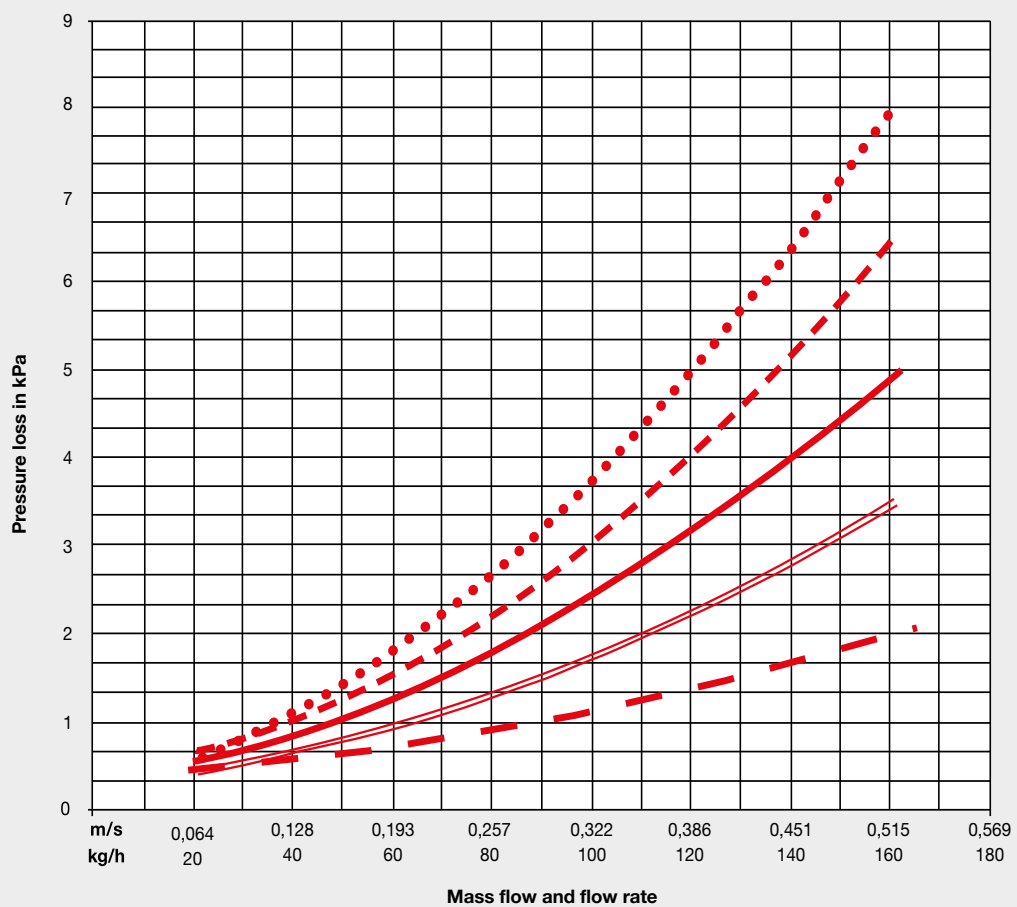

- 600 x 3,000
- - - - 600 x 2,400
- 600 x 1,800
- ==== 600 x 1,200
- · - · 600 x 600

Series connections available on request.

Heating and cooling performance

The following tables show the heating and cooling performance of Zehnder Alumline. The given heating and cooling performance values are measured based on EN 14037-3 (heating) and EN 14240 (cooling).

Thermal outputs for 6-pipe activation										
Sail module / ceiling sail with insulation						Sail module / ceiling sail without insulation				
Dimensions	600 x 600	600 x 1200	600 x 1800	600 x 2400	600 x 3000	600 x 600	600 x 1200	600 x 1800	600 x 2400	600 x 3000
K	1,8777	3,7554	5,6331	7,5108	9,3885	2,4136	4,8272	7,2409	9,6545	12,068
n			1,163					1,191		
Δ t (K)	W	W	W	W	W	W	W	W	W	W
70	263	525	788	1051	1314	380	761	1141	1521	1902
68	254	508	762	1016	1270	367	735	1102	1470	1837
66	245	491	736	981	1227	355	709	1064	1418	1773
64	237	473	710	947	1184	342	684	1026	1367	1709
62	228	456	684	913	1141	329	658	987	1317	1646
60	220	439	659	878	1098	317	633	950	1266	1583
58	211	422	633	844	1056	304	608	912	1216	1520
56	203	405	608	811	1013	292	583	875	1166	1458
55	198	397	595	794	992	285	571	856	1142	1427
54	194	389	583	777	971	279	558	838	1117	1396
52	186	372	558	744	930	267	534	801	1068	1335
50	178	355	533	711	888	255	510	764	1019	1274
48	169	339	508	678	847	243	485	728	971	1213
46	161	322	484	645	806	231	461	692	923	1153
44	153	306	459	612	765	219	438	656	875	1094
42	145	290	435	580	725	207	414	621	828	1035
40	137	274	411	548	685	195	391	586	781	977
38	129	258	387	516	645	184	367	551	735	919
36	121	242	364	485	606	172	345	517	689	861
34	113	227	340	454	567	161	322	483	644	805
32	106	211	317	423	529	150	299	449	599	749
30	98	196	294	392	490	139	277	416	555	693
28	91	181	272	362	453	128	255	383	511	639
26	83	166	249	332	415	117	234	351	468	585
24	76	151	227	303	378	106	213	319	425	531
22	68	137	205	273	342	96	192	287	383	479
20	61	122	184	245	306	86	171	257	342	428
18	54	108	162	217	271	75	151	226	302	377
16	47	94	142	189	236	66	131	197	262	328
14	40	81	121	162	202	56	112	168	224	280
12	34	68	101	135	169	47	93	140	186	233
10	27	55	82	109	137	37	75	112	150	187

Note: Removing the insulation has a positive effect on the cooling capacity (see table). However, this increase can only be calculated with an open ceiling.

Removing the insulation increases the thermal output; however, this can lead to heat accumulation under higher ceilings.

Cooling capacities for 6-pipe activation										
Sail module / ceiling sail with insulation						Sail module / ceiling sail without insulation				
Dimensions	600 x 600	600 x 1200	600 x 1800	600 x 2400	600 x 3000	600 x 600	600 x 1200	600 x 1800	600 x 2400	600 x 3000
K	3,0777	6,5489	10,02	13,491	16,962	3,1278	6,6553	10,183	13,71	17,238
n			1,0695					1,0869		
Δ t (K)	W	W	W	W	W	W	W	W	W	W
15	56	119	181	244	307	59	126	193	260	327
14	52	110	169	227	285	55	117	179	241	304
13	48	102	156	210	264	51	108	165	223	280
12	44	93	143	192	242	47	99	152	204	257
11	40	85	130	175	220	42	90	138	186	234
10	36	77	118	158	199	38	81	124	167	211
9	32	69	105	141	178	34	72	111	149	188
8	28	61	93	125	157	30	64	98	131	165
7	25	52	80	108	136	26	55	84	114	143
6	21	45	68	92	115	22	47	71	96	121
5	17	37	56	75	95	18	38	59	79	99
4	14	29	44	59	75	14	30	46	62	78
3	10	21	32	44	55	10	22	34	45	57
2	6	14	21	28	36	7	14	22	29	37
1	3	7	10	13	17	3	7	10	14	17

Heating and cooling performance

The following tables show the heating and cooling performance of Zehnder Alumline. The given heating and cooling performance values are measured based on EN 14037-5 (heating) and EN 14240 (cooling).

Thermal outputs for 6-pipe activation										
Lay-in module with insulation						Lay-in module without insulation				
Dimensions	595 x 592	595 x 1,192	595 x 1,792	595 x 2,392	595 x 2,992	695 x 592	595 x 1,192	595 x 1,792	595 x 2,392	595 x 2,992
K	1,6864	3,5883	5,4902	7,3921	9,294	1,7101	3,6388	5,5675	7,4961	9,4248
n			1,0959					1,0979		
Δ t (K)	W	W	W	W	W	W	W	W	W	W
70	177	378	578	778	978	181	386	591	795	1000
68	172	366	560	753	947	176	374	572	770	969
66	166	354	542	729	917	170	362	554	746	937
64	161	342	524	705	886	164	350	535	721	906
62	155	330	506	681	856	159	338	517	696	875
60	150	319	488	657	826	153	326	499	672	844
58	144	307	470	633	796	148	314	481	647	813
56	139	296	452	609	766	142	302	462	623	783
55	136	290	443	597	751	139	296	453	610	767
54	134	284	435	585	736	136	290	444	598	752
52	128	273	417	561	706	131	279	426	574	722
50	123	261	399	538	676	125	267	408	550	691
48	117	250	382	514	647	120	255	390	526	661
46	112	238	365	491	617	114	244	373	502	631
44	107	227	347	468	588	109	232	355	478	601
42	101	216	330	444	559	104	220	337	454	571
40	96	204	313	421	530	98	209	320	430	541
38	91	193	296	398	501	93	197	302	407	511
36	86	182	279	375	472	87	186	285	383	482
34	80	171	262	352	443	82	175	267	360	453
32	75	160	245	330	415	77	163	250	337	423
30	70	149	228	307	386	72	152	233	314	394
28	65	138	212	285	358	66	141	216	291	366
26	60	128	195	263	330	61	130	199	268	337
24	55	117	179	241	303	56	119	182	246	309
22	50	106	162	219	275	51	108	166	223	281
20	45	96	146	197	248	46	98	149	201	253
18	40	85	130	176	221	41	87	133	179	225
16	35	75	115	154	194	36	76	117	157	198
14	30	65	99	133	168	31	66	101	136	171
12	26	55	84	113	142	26	56	85	115	144
10	21	45	68	92	116	21	46	70	94	118

Note: Removing the insulation has a positive effect on the cooling capacity (see table). However, this increase can only be calculated with an open ceiling.

Removing the insulation increases the thermal output; however, this can lead to heat accumulation under higher ceilings.

Cooling capacities for 6-pipe activation										
Lay-in module with insulation						Lay-in module without insulation				
Dimensions	595 x 592	595 x 1,192	595 x 1,792	595 x 2,392	595 x 2,992	695 x 592	595 x 1,192	595 x 1,792	595 x 2,392	595 x 2,992
K	2,4513	5,2159	7,9805	10,745	13,51	2,4912	5,3007	8,1103	10,92	13,729
n			1,0911					1,0911		
Δ t (K)	W	W	W	W	W	W	W	W	W	W
15	47	100	153	206	259	48	102	156	210	264
14	44	93	142	191	241	44	94	144	194	244
13	40	86	131	176	222	41	87	133	179	225
12	37	78	120	162	203	37	80	122	164	207
11	34	71	109	147	185	34	73	111	149	188
10	30	64	98	133	167	31	65	100	135	169
9	27	57	88	118	149	27	58	89	120	151
8	24	50	77	104	131	24	51	78	106	133
7	20	44	67	90	113	21	44	68	91	115
6	17	37	56	76	95	18	37	57	77	97
5	14	30	46	62	78	14	31	47	63	79
4	11	24	36	49	61	11	24	37	50	62
3	8	17	26	36	45	8	18	27	36	46
2	5	11	17	23	29	5	11	17	23	29
1	2	5	8	11	14	2	5	8	11	14

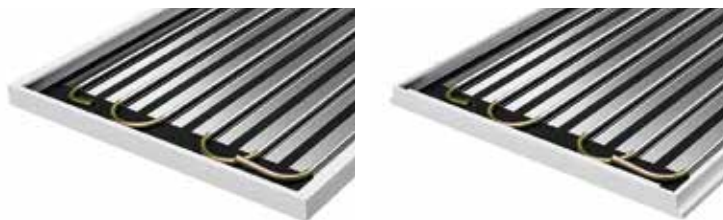
Technical specifications for 6-pipe activation

		Sail module for the ceiling sail					Lay-in module				
Dimensions	Unit of measurement										
Width type	-	600					600				
Length type ²⁾	-	600	1,200	1,800	2,400	3,000	600	1,200	1,800	2,400	3,000
Actual width	mm	600					595				
Actual length ²⁾	mm	600	1,200	1,800	2,400	3,000	592	1,192	1,792	2,392	2,992
Number of suspension points per module	Piece	4	4	4	4	6	4	4	4	4	6
No. of parallel pipes	Piece	6					6				
Tube spacing	mm	90					90				
Pipe material / dimension (outside ø)	- / mm	D copper pipe / 12					D copper pipe / 12				
Panel material	-	Galvanised steel					Galvanised steel				
Parameters											
Max. operating temperature ¹⁾	°C	83					83				
Max. operating pressure ²⁾	bar	6					6				
Weight											
Operating weight with water, without insulation	kg	4.04	7.78	11.53	15.27	19.01	3.61	6.99	10.82	14.20	19.36
Operating weight with water, with insulation ³⁾	kg	4.19	8.12	12.04	15.96	19.88	3.77	7.33	11.33	14.90	20.24
Water content	kg	0.39	0.75	1.11	1.47	1.83	0.39	0.75	1.11	1.47	1.83

¹⁾ A max. operating temperature of 50 °C only is possible with the perforated version.

²⁾ Higher operating pressure on request.

³⁾ Insulation made of mineral wool in LDPE foil, mass per unit area = 0.84 kg/m², λ = 0.03 - 0.04 W/(m*K)

Tender specification

Manufacture

The radiant panels shall be supplied by Zehnder UK, Watchmoor Point, Camberley, Surrey GU15 3AD. The panels are manufactured according to the TAIM e.V. quality standard, version: November 1998. The material will be galvanised sheet steel with a minimum thickness of 0.6 mm, with the lip on longitudinal side in line with static requirements.

The radiant panels will have a surface similar to RAL 9016, with the option of perforation, with hole pattern RD - L30 (diameter 1.5 mm - 22% - 45°), surrounding non-perforated edge, approx. 10 mm wide. A special heat-conducting acoustic fleece has been force-fitted to the back of the perforated version, without pleats, to improve sound absorption. Sound absorption measured according to EN ISO 345.

The radiant panels are suitable as lay-in modules/grids or as free-hanging ceiling sails.

Design

The radiant panels will be 600 mm in width (595 mm for lay-in modules/grids), and lengths up to 3,000 mm (2,992 mm for lay-in modules/grids) in increments of 600 mm starting from 600 mm.

Installation: Lay-in modules for T24 grid ceiling

The panels will be suitable for a T24 ceiling construction for heating and cooling ceiling modules.

The panels will lay flush, as lay-in metal cassettes for a visible T24 track supporting structure for heating and cooling, in a perforated or smooth version, for removing sensitive heat loads in an approximate ratio of 70% via radiation and 30% via convection.

A minimum suspension height of 350 mm (bottom edge of bare ceiling to upper edge of heating and cooling ceiling) is recommended.

Components and additional loads must be suspended from the bare ceiling separately; alternatively, they can be attached by means of reinforcements on the back of the panels, additional profiles and additional suspending brackets on the substructure. The supplementary work must be carried out professionally.

Hydraulic pipework for the individual metal cassettes as per the room-specific calculations.

Hoses connected to the outlet connectors of the pipework on the room side by 12 mm outlets.

Insulation

Heat and sound-absorbing insulating layer based on mineral wool, coated with black fleece on one side and shrink wrapped in LDPE foil as an option.

Pipe register

Factory-integrated copper pipe register with large-area aluminium heat-conducting profiles in the shape of the module, with flow and return connections. D-pipes (12 mm) made of copper according to EN 12735-2.

The copper pipe registers are pressed against the panel sheet by the aluminium profiles at the factory using a special adhesive thus ensuring optimum thermal transfer and, as such, optimum heating and cooling performance. The size of the meandering copper pipe is tailored to the ceiling module. The pipe spacing and the number of heat-conducting profiles and copper pipes must be selected, so that the given technical specification can be achieved.

The cooling ceilings should be hydraulically connected so there is a max. pressure loss of 25 kPa per control circuit.

Performance

Thermal output certified to EN 14037-3 for free-hanging panels, approx. 888 W @ ΔT 50 K and certified to EN 14037-5 for lay-in modules /grid, approx. 676 W @ ΔT 50 K based on testing of a 3,000 mm length panel.

Cooling output certified to EN 14240, approx. 157 W @ ΔT 8 K for e.g. 600 mm x 3,000 mm with insulation free-hanging ceiling sails and 131 W @ ΔT 8 K for e.g. 595 mm x 2992 mm with insulation lay-in modules/grid applications.

Maximum operating temperature: 83 °C
Maximum operating pressure: 6 bar

Flexible Hoses

The Zehnder oxygen impermeable hose approved for heating systems, compliant to DIN 4726 consisting of temperature-resistant resilient butyl with a stainless steel braided sleeve and with brass push-fit connectors pressed on both sides.

The flexible hose connections with steel braiding will be 12 x 12 mm for panel inter-connections and 12 x 15 mm for connection to supply pipework. The connectors will be 750 mm, 1,000 mm, 1,500 mm or 2,500 mm in length.

The connectors will work with a max. operating temperature of 80 °C and a max. operating pressure of 6 bar. A stainless steel corrugated version with a max. operating temperature of 83 °C is available on request.

Plastic connectors are not permitted. Push-fit connector on both sides for copper pipe (12 mm).

The copper pipes used on site to connect the flexible connection pipes must meet the requirements of EN 1057. Only copper pipes in the R220 (soft) and R250 (half hard) variant are permitted.

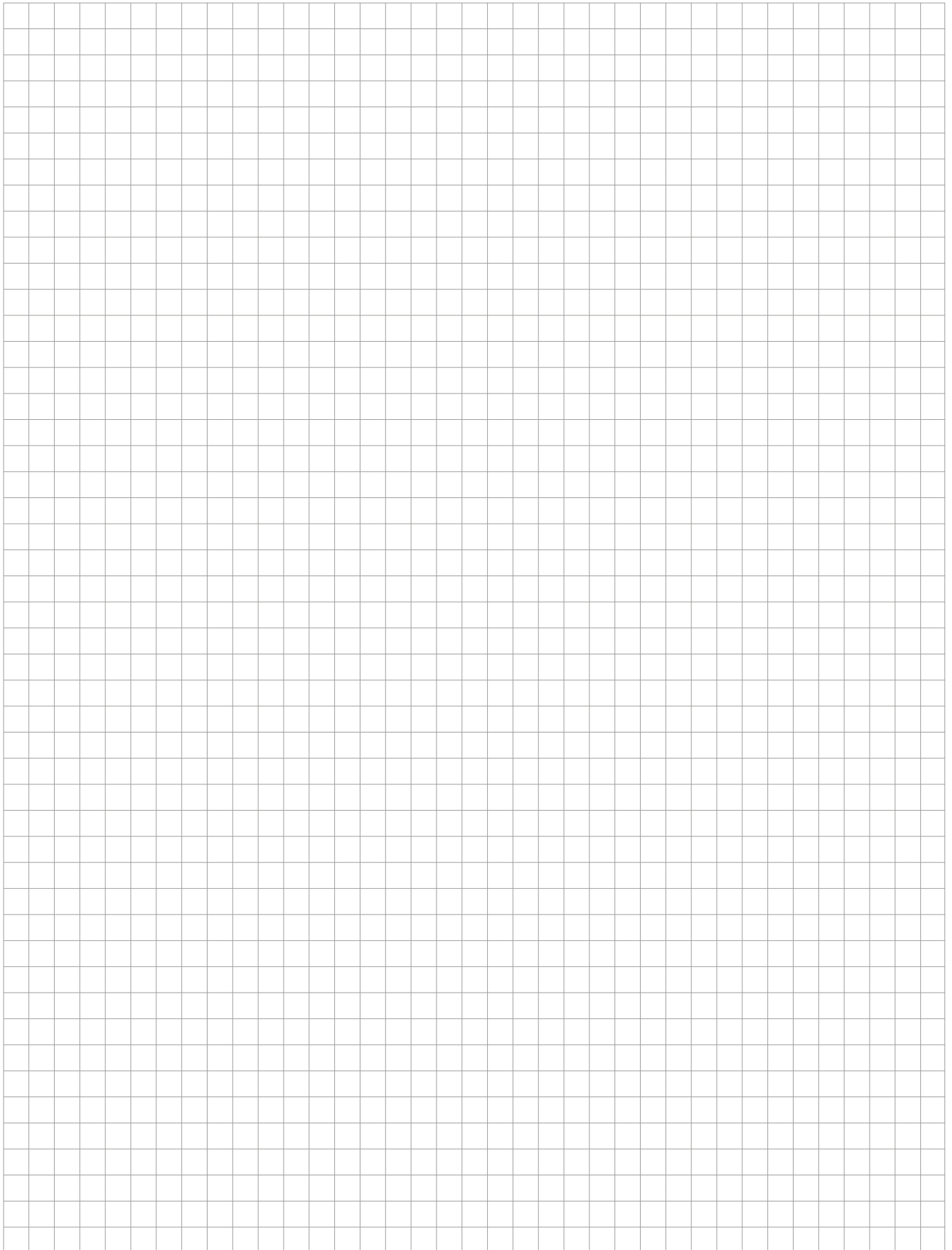

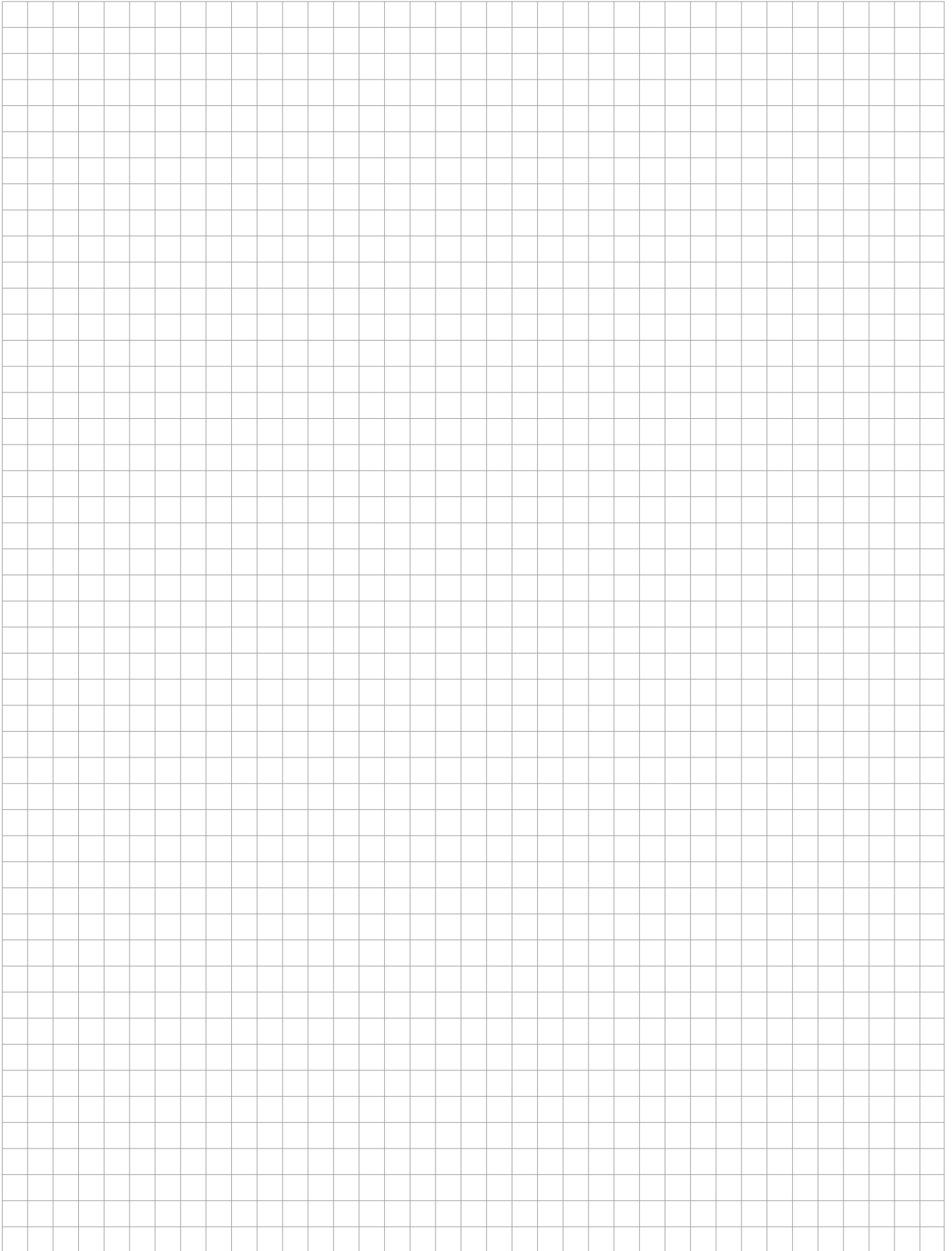

ALWAYS THE BEST CLIMATE

“We strive to improve the quality of life by providing the finest indoor climate solutions.”



Excellent team

Every day we combine passion, expert knowledge and commitment to give you the best results.



Great solutions, products and services

Great products and unique service for an energy-efficient, healthy and comfortable indoor climate.

WE ARE THE SPECIALISTS FOR A HEALTHY, COMFORTABLE AND ENERGY-EFFICIENT

The broad and clearly structured portfolio from the Zehnder Group is split into four product lines. Consequently, we can provide our customers with the right product, perfect system and matching service for all types of projects – from new build to renovations, single or multi-occupancy homes, as well as commercial projects. This variety ensures that our wealth of experience is continuously expanding, providing tangible added value to our customers on a daily basis.



Decorative radiators

Our individual decorative radiators for living and bathrooms make a home not only warmer but also more attractive. Created by renowned designers, they impress with excellent functionality.

OUR BRANDS REPRESENT INNOVATION, QUALITY AND DESIGN

zehnder

The Zehnder brand offers excellent indoor climate solutions within the product lines of decorative radiators, comfortable indoor ventilation, heating and cooling ceiling systems and clean air solutions.

BISQUE

The Bisque brand offers beautiful but practical radiators in the most exciting styles, colours and shapes for homes and more.



First choice for customers

Always close to the needs of our customers, to grow with you and overcome all challenges together.

INNOVATION OVER 4 GENERATIONS

MANUFACTURER OF THE WORLD'S

1st

STEEL AND BATHROOM RADIATORS

REPRESENTED IN MORE THAN

70 COUNTRIES

AROUND **3,500** EMPLOYEES

16 OF OUR OWN PRODUCTION PLANTS IN EUROPE, NORTH AMERICA AND CHINA

INNOVATION SINCE **1895**

1,200 PATENTS AND DESIGN RIGHTS THROUGHOUT THE WORLD

AROUND **20,000** TRAINED CUSTOMERS PER YEAR

INDOOR CLIMATE



Comfortable indoor ventilation

Our comfortable indoor ventilation is energy-efficient and provides a healthy indoor climate. It promotes the wellbeing of the occupants and increases the value of the property.



Heating and cooling ceiling systems

Zehnder ceiling systems are convenient and energy-efficient for heating and cooling. They are perfectly attuned to the relevant environment.



Clean air solutions

Clean air systems from Zehnder reduce the level of dust in the air, create a healthier working environment and reduce the amount of cleaning required.



The Greenwood Airvac brand offers a range of low energy, smart residential ventilation solutions from intermittent extract fans to whole house ventilation with heat recovery.

BEST QUALITY CERTIFICATES

Zehnder Group products are frequently awarded prizes for design and innovative technology.





Versatile · Beechmount Homepark · Navan · Co. Meath
T +353 (0) 4690 29444 · F +353 (0) 4690 27705 · sales@versatile.ie · www.versatile.ie

Zehnder Group UK · Watchmoor Point · Camberley · Surrey · GU15 3AD
T +44 (0) 1276 605800 · sales@zehnder.co.uk · www.zehnder.co.uk
Registered in England 2296696