

### Application: Suspended Ceilings

Suitable for integration into a 600mm x 600mm ceiling, Electric Trident Panels blend into the ceiling to give an almost invisible heating solution. They are aesthetically identical to our LTHW panels whilst using electric heating mats instead of copper pipes.

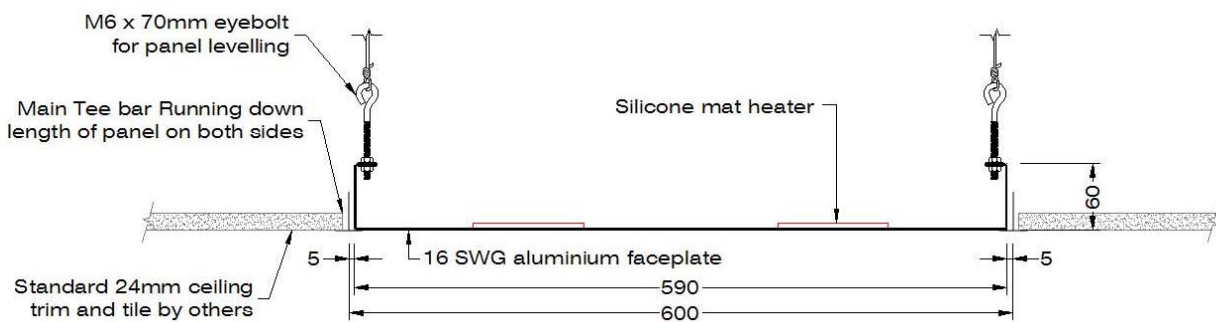

### Trident Modular Panels

Trident Modular panels are available in nominal lengths from 600mm up to 3000mm (in 600mm increments)

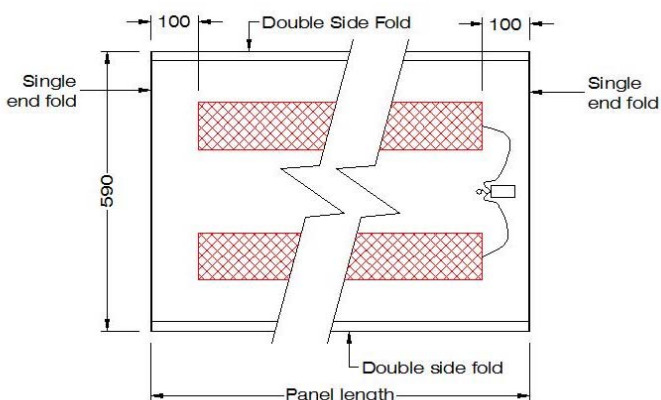

# Electric Trident Linear Panels

Trident Linear panels are Trident panels that are longer than 3000mm. They are made up of separate 3m (or smaller) panels that are pushed together on site using discreet expansion strips to cover the join.



## Electric Trident Technical Specification

- 1.6mm smooth aluminium faceplates, free of any ridges and lines
- Factory finished in a white texture to RAL 9010 (other colours can be provided)
- 1.1mm thick moisture resistant silicone rubber electric heater mats self adhered to reverse of panel.
- Max temperature 180°C (requires high temp paint) – usually 60-80°C
- Thermal safety cut out included
- Wired with connection block for wiring to the mains and site testing by others.
- Insulated with 50mm foil backed unencapsulated glass fibre with a thermal conductivity at 70°C of 0.045 W/m K
- Panel mass: 600mm wide ~5-7 kg/m
- The outputs of our panels have been tested to BS EN 14037