

HERZ DR Fully Lugged Butterfly Valve PN16

Standard sheet for
BF-DR-FLG
(0914)

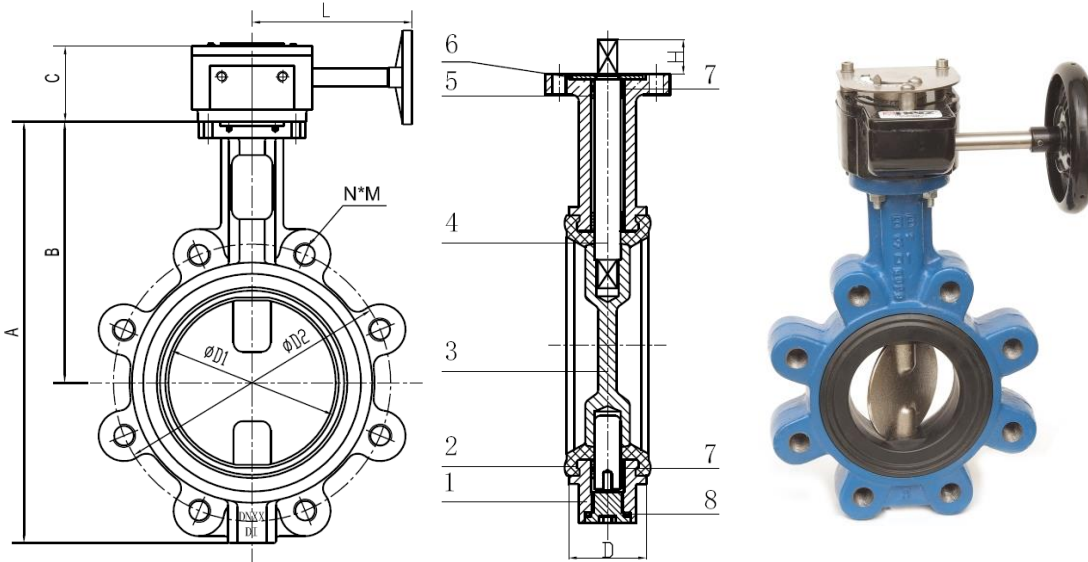

Size	ØD1	ØD2	N*M	A	B	C	D	H	L	Weight
	mm	mm		mm	mm	mm	mm	Mm	mm	kg
DN65	65.6	145	4xM16	202	133	72	46	29	112	8.0
DN80	80	160	8xM16	238	152	72	46	29	112	8.7
DN100	102.2	180	8xM16	276	170	72	52	29	112	11.3
DN125	125.6	210	8xM16	296	181	72	56	29	112	13.8
DN150	150.6	240	8xM20	324	196	72	56	29	112	15.0
DN200	200.4	295	12xM20	398	238	84	60	41	171	28.1

Dimensions

No	Item	Material	Specification	Operator
1	Body	Cast Iron	BS EN1561 EN-JL1040	Gear
2	Seat	EPDM	WRAS 0504515EPDM	
3	Disc	Stainless Steel	CF8	
4	Shaft	Stainless Steel	SS416	
5	Bearing	PTFE	PTFE	
6	Plate	Steel	ASTM A283	
7	O Ring	Elastomer	EPDM	
8	Gasket	Elastomer	EPDM	

Materials

EN593
Face to Face: EN558-1
End Flange: BS EN 1092-2 PN16
Top Flange: ISO5211

Working Temperature: -10 to 120°C
Test pressure
Shell 24 bar
Seat 17.6 bar

Specification



Herz Valves UK Ltd
Progress House
Moorfield Point
Moorfield Road
Guildford
Surrey
GU1 1RU

Tel 01483 502211
Fax 01483 502025

Sales@herzvalves.com

www.herzvalves.com