

versatile

Heating



Light cooling



Deep cooling



BRIZA 12

Compact and quiet fan convector in a slim design or for built-in installation

Briza 12 is the best solution if you want to combine power with a sleek design.

Jaga Briza fan convectors ensure the highest climate comfort while being energy-efficient and whisper-quiet. They bring every room up to temperature very quickly, both in winter and in summer. This way you can enjoy an ideal indoor climate year-round.

- Also for residential projects
- Built-in EC motor for a much lower energy consumption and a longer service life
- Suitable for connection to any heat source
- Ideal in combination with heat pumps and low temperature systems
- Optimized cooling capacity due to the new hydrophilic protection of the copper-aluminum coil.
- With built-in room thermostat or controllable via the latest home automation systems
- For 2-pipe or 4-pipe
- Also available in a ceiling model or for in-wall or in-ceiling installation

Suitable for non-condensing and condensing cooling



jaga
QUALITY
MADE IN BELGIUM



BRIZA 12



BRIZA 12 ▪ PLUG & PLAY

BRIZA PLUG & PLAY: QUALITY IN EVERY DETAIL

Heat exchanger with hydrophilic coating for optimum cooling performance

Sturdy casing manufactured from electro-galvanised steel

aluminum top grille, in the color of the device



Wi-Fi thermostat with touchscreen and app.*

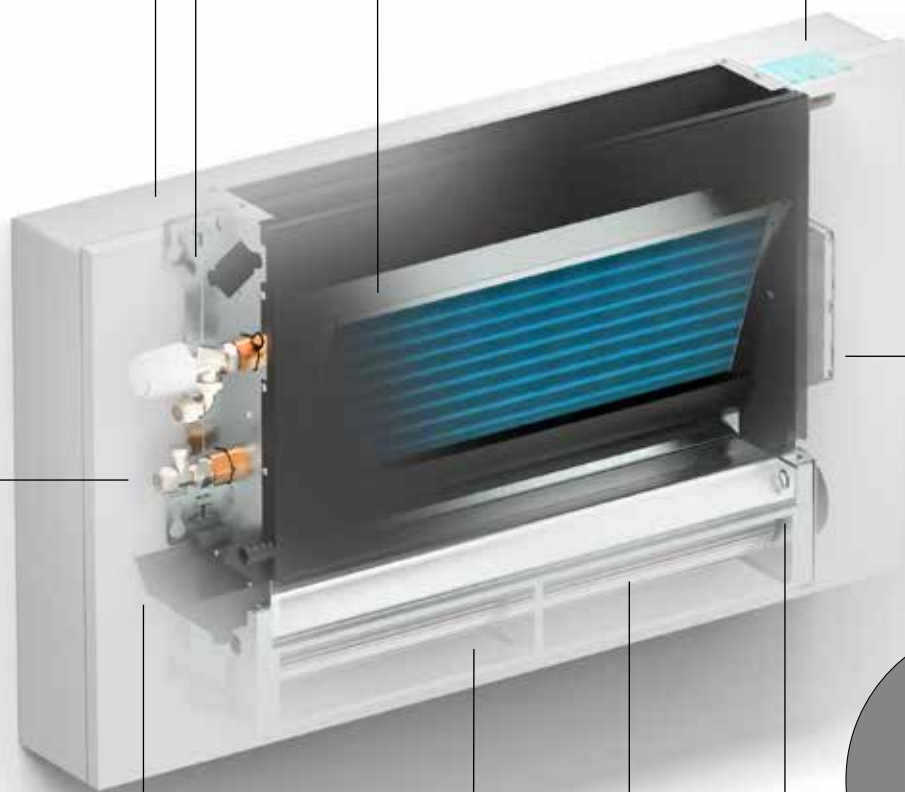

Metal condensate tray with epoxy-polyester coating

Stainless steel air filter

Tangential activators with aluminium fins are provided with ball bearings and resin-coated EPDM vibration damping



Preassembled connection set for an easy 3/4" Euroconus connection. *

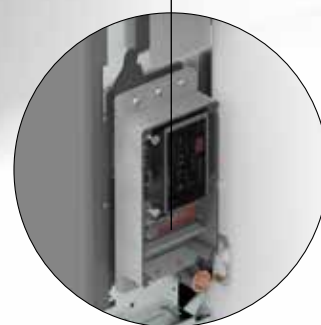

Integrated 230 V power supply, with clamp connector. *

Built-in EC motor for a much lower energy consumption and a longer service life

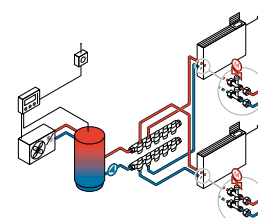

Installation scheme see p. 280

EASY TO CONTROL WITH THE NEW WI-FI THERMOSTAT

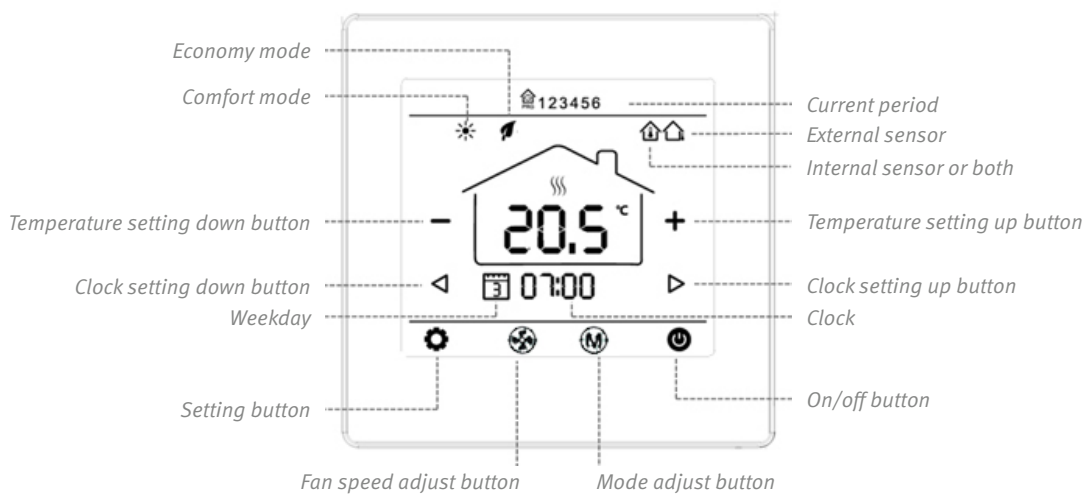

The thermostat and accompanying app enable the creation of a comfortable climate for each individual room. Operation can be done via the LCD touchscreen with background lighting (1) or via the app (2). Easily add different devices (3). Manual selection of the ideal temperature (4) & (5) Program your weekly program(6).



BRIZA 12 ■ PLUG & PLAY

DIMENSIONS (in cm)

Completely preassembled devices with built-in power supply 24 VDC, WIFI-thermostat and valves

H041

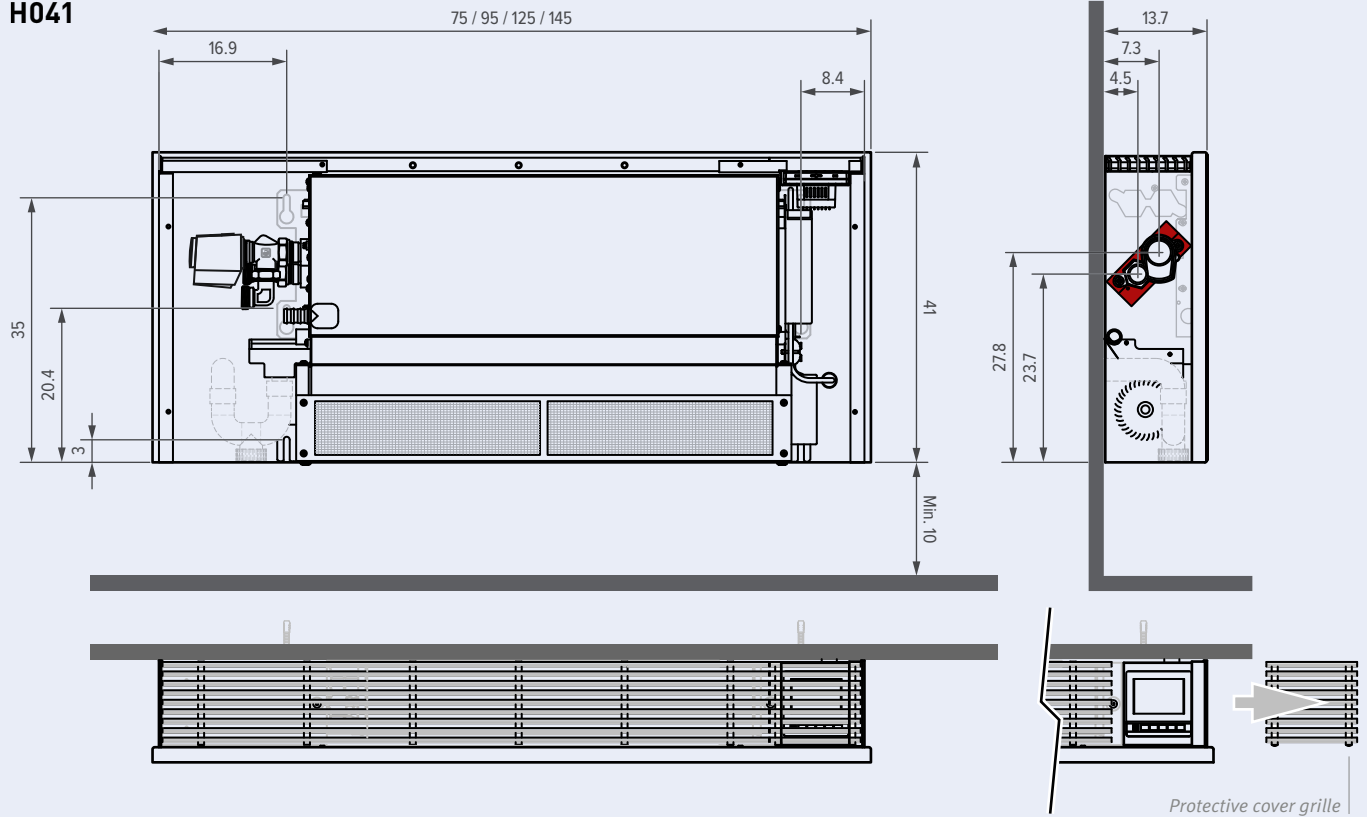

H055

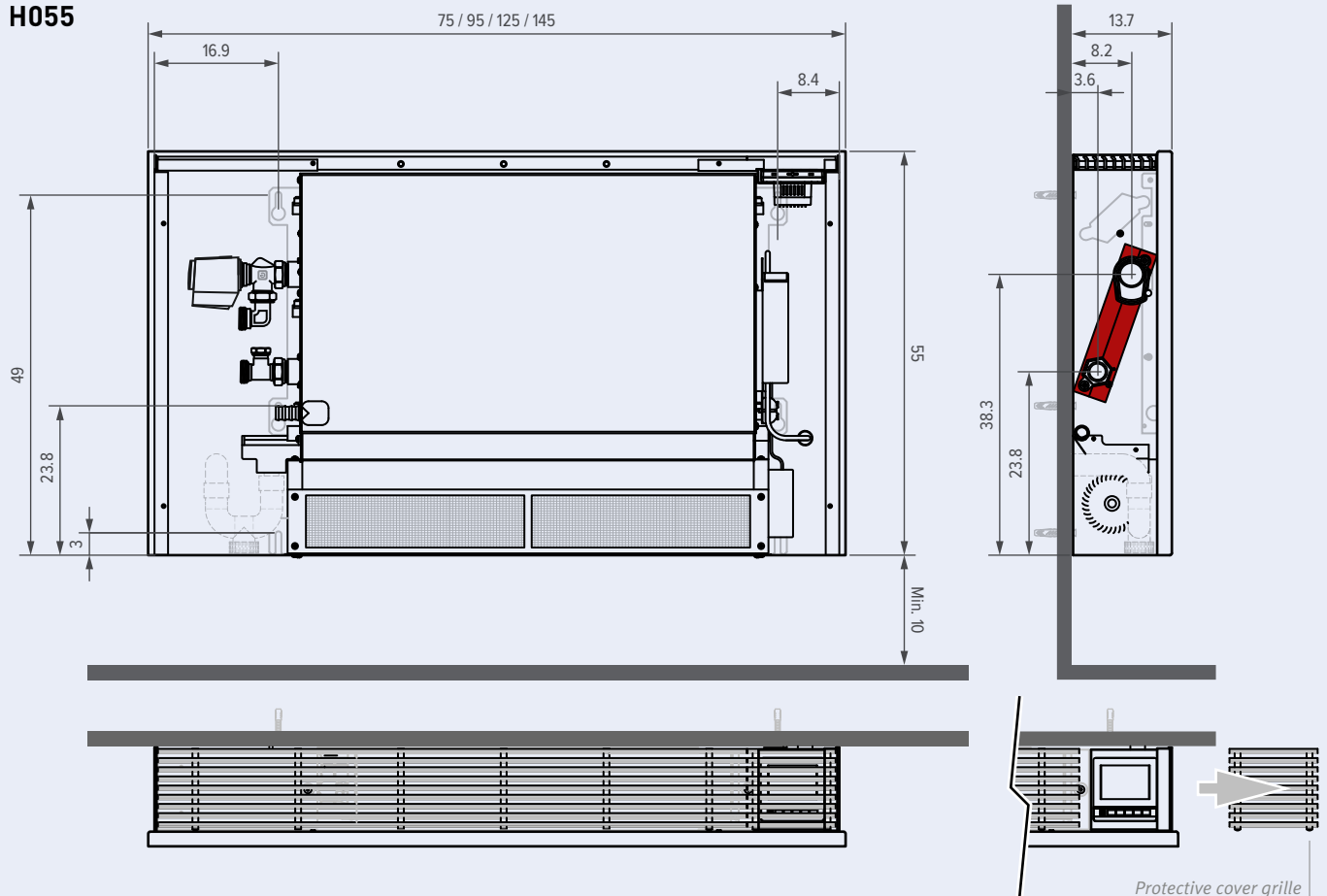

STANDARD DELIVERY

- Integrated Wi-Fi thermostat with LCD touchscreen and app
- Integrated power supply 230 VAC > 24 VDC
- Integrated 24 VDC two-way valve connection with 3/4" Euroconus hydraulic connections on the left.
- Coating made from sendzimir galvanized steel plate with an aluminum grille in the same color.
- Sturdy casing manufactured from electro-galvanised steel
- Stainless steel air filter
- Condensate drain for deep cooling Ø 20mm
- Copper-aluminum 2-pipe hydrophilic coated heat exchanger, G1/2" F.
- EC fans with dustproof ball bearings and vibration damping.
- Order sleeve couplings 3/4" Eurocone separate

CONNECTION

Standard connection:
3/4" Euroconus hydraulic connections on the left

COLOUR

traffic white RAL 9016 (133), soft touch lightly structured satin powder coating

All technical information
Go to jaga.com

DIMENSIONS			CONTROL VOLTAGE	HEATING ROOM TEMPERATURE 20°C				COOLING TOTAL Room temperature 27°C		COOLING SENSIBLE Room temperature 27°C	COOLING (NON-CONDENSING) Room temperature 27°C	SOUND PRESSURE* dB(A)	AIR FLOW m³/h	ELECTRIC POWER CONSUMPTION Watts	STANDARD COLOURS €	 2-PIPE
H cm	L cm	T cm		U V	75/65 Watts	55/45 Watts	45/35 Watts	35/30 Watts	7/12 Watts	7/12 Watts	16/18 Watts					
041	075	12	2	903	538	355	223	284	201	115	18.5	70	1.6	1514	BZMP.041 075 12.133 /20	
			4	1035	617	406	256	328	235	135	29.4	111	2.6			
			6	1194	712	469	296	382	276	159	31.3	155	4.3			
			8	1399	834	550	346	441	323	185	37.3	196	7.2			
			10	1669	996	656	413	503	373	214	42.5	235	13.0			
095	12		2	1545	921	607	382	472	334	191	24.0	119	2.5	1595	BZMP.041 095 12.133 /20	
			4	1699	1014	668	421	529	379	217	30.0	189	4.3			
			6	1797	1072	706	445	607	440	252	36.8	245	7.2			
			8	2243	1338	881	555	707	518	297	41.5	315	11.5			
			10	2749	1640	1080	680	828	614	352	44.5	380	18.0			
125	12		2	2431	1450	955	602	773	547	313	24.6	160	2.6	1825	BZMP.041 125 12.133 /20	
			4	2717	1620	1067	672	845	605	347	30.2	243	4.8			
			6	3090	1843	1214	765	953	691	396	37.0	328	8.0			
			8	3617	2157	1421	895	1106	811	465	42.5	419	14.0			
			10	4367	2604	1715	1081	1314	974	559	47.0	492	24.0			
145	12		2	2999	1788	1178	742	1015	718	412	25.7	190	2.8	1908	BZMP.041 145 12.133 /20	
			4	3401	2028	1336	842	1097	785	450	30.5	295	5.5			
			6	3894	2323	1530	964	1215	881	505	37.3	410	10.3			
			8	4551	2714	1788	1126	1390	1019	584	43.0	512	18.5			
			10	5444	3247	2138	1347	1640	1216	698	47.0	560	28.8			
055	075	12	2	1400	835	550	346	419	296	170	19.2	89	2.0	1763	BZMP.055 075 12.133 /20	
			4	1701	1014	668	421	521	373	214	25.2	130	3.2			
			6	2000	1193	786	495	617	447	256	32.2	169	5.5			
			8	2295	1369	902	568	705	517	296	38.1	212	9.6			
			10	2588	1544	1017	641	781	579	332	42.5	250	16.8			
095	12		2	2250	1342	884	557	728	515	295	23.0	127	2.2	1886	BZMP.055 095 12.133 /20	
			4	2781	1658	1092	688	872	624	358	27.8	193	3.6			
			6	3309	1973	1300	819	1025	743	426	34.4	262	5.7			
			8	3816	2276	1499	944	1171	859	492	39.9	320	9.6			
			10	4285	2555	1683	1060	1294	959	550	43.5	365	15.6			
125	12		2	3561	2124	1399	881	1170	827	474	23.1	168	2.8	2189	BZMP.055 125 12.133 /20	
			4	4420	2636	1736	1094	1387	993	569	29.1	259	5.4			
			6	5280	3149	2074	1307	1628	1179	676	36.5	353	10.0			
			8	6097	3637	2395	1509	1863	1365	783	42.5	437	18.0			
			10	6831	4074	2683	1690	2062	1529	877	46.5	513	28.8			
145	12		2	4509	2689	1771	1116	1455	1029	590	25.0	200	2.8	2328	BZMP.055 145 12.133 /20	
			4	5525	3295	2170	1367	1728	1237	709	30.8	297	5.5			
			6	6588	3929	2588	1630	2030	1471	843	37.5	396	10.0			
			8	7615	4542	2991	1884	2324	1704	977	42.8	500	18.0			
			10	8526	5085	3349	2110	2575	1910	1095	46.5	583	28.8			

Output measured in accordance with EN16430

*Schallmessung nach ISO 3741:2010, 2 m von das Gerät entfernt und bei einer angenommenen Raumdämpfung von 8 dB(A) / Rauminhalt 100 m³ / Nachschallzeit 0.5 sec.

BRIZA 12 ■ BASIC ■ WITH CASING

BZBW INSTALLATION IN A WALL RECESS

BZBC BUILT-IN CEILING

Hydraulic connection
 2-pipe 1/2"
 4-pipe 1/2"

Sturdy casing manufactured
 from electro-galvanised steel

Heat exchanger with hydrophilic
 coating for optimum cooling
 performance

Metal condensate tray with
 epoxy-polyester coating

Tangential fans



Electrical connection



EC motor 24 VDC

Stainless steel air filter

Mounting of the fan blade using
 dust/oil-free ball bearings

DIMENSIONS (in cm)

H 52 / 2-pipe H 52 / 4-pipe H 38 / 2-pipe H 38 / 4-pipe

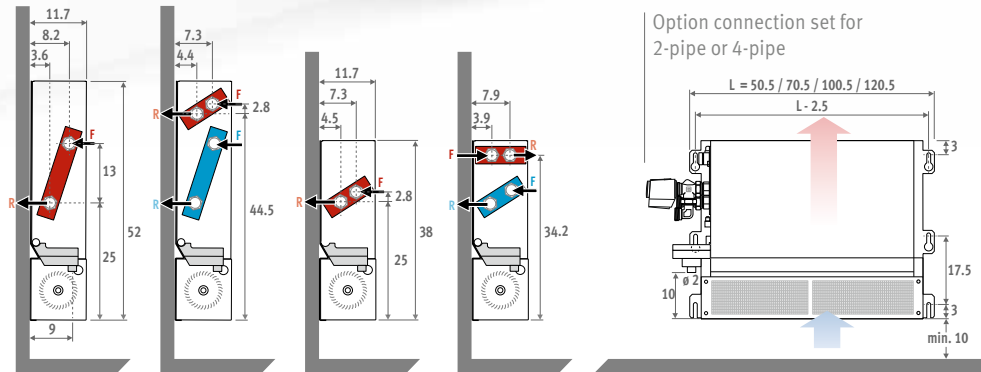

Built-in model with air outlet corner piece

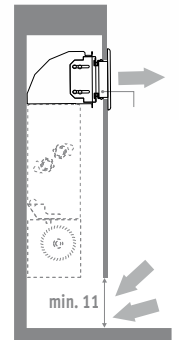

BUILT-IN CEILING (in cm)

H 52 / 2-pipe

H 52 / 4-pipe

Built-in model with air outlet corner piece

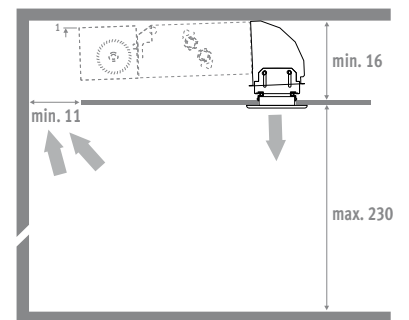
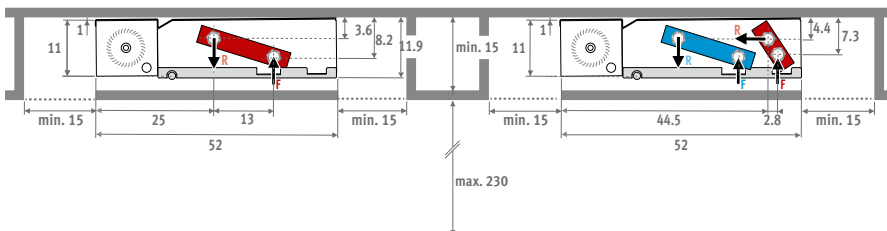

H 38 / 2-pipe

H 38 / 4-pipe

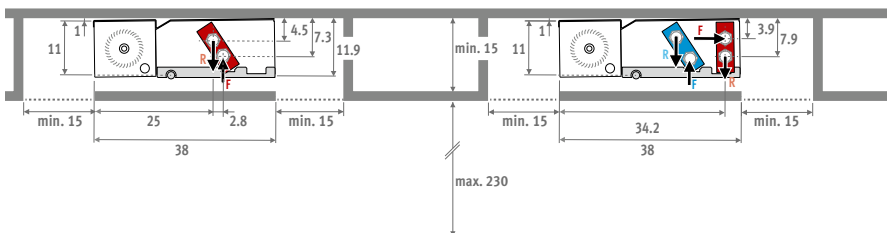

WITH CASING (BZMW - BZMC) - BASIC - BRIZA12

BZMW WALL MOUNTED MODEL

aluminium top grille, powder coated in the same colour as the unit

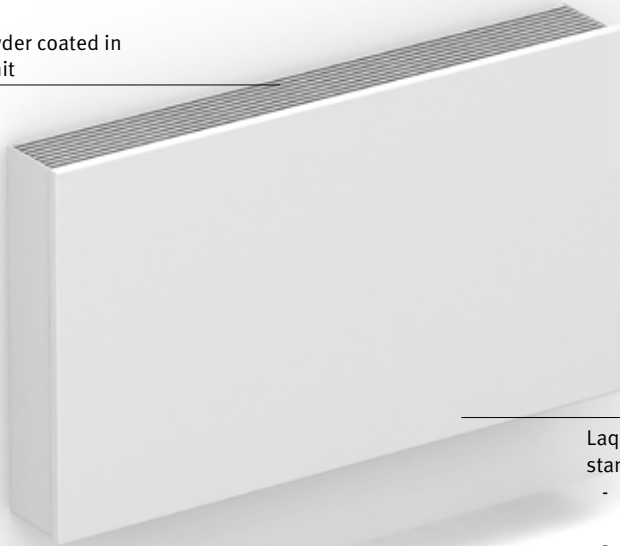

BZMC CEILING MOUNTED MODEL



Laquered casing in sendzimir galvanized steel plate standard colours:

- traffic white RAL 9016 (133), soft touch lightly structured satin powder coating
- sandblast grey (001), fine texture metallic powder coating
- off-black (145), soft touch lightly-textured satin lacquer

Other colours: see colour chart

DIMENSIONS (in cm)

H 55 / 2-pipe

H 55 / 4-pipe

H 41 / 2-pipe

H 41 / 4-pipe

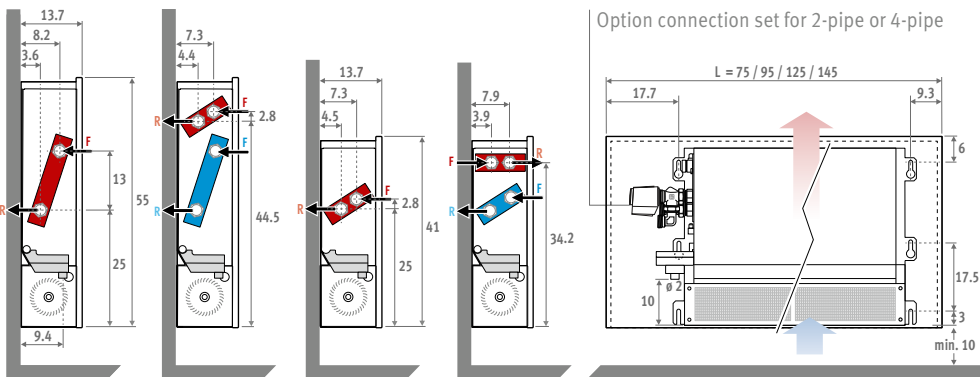

CEILING MOUNTED MODEL (in cm)

H 55 / 2-pipe

H 55 / 4-pipe

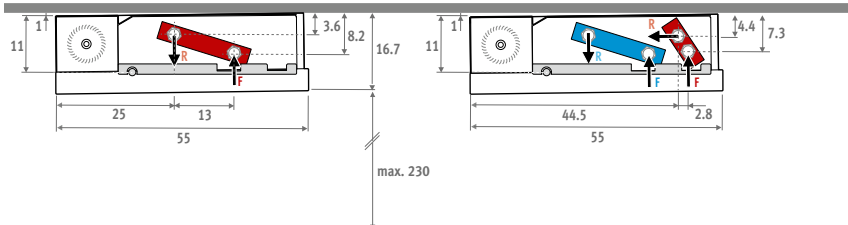

H 41 / 2-Rohr

H 41 / 4-pipe

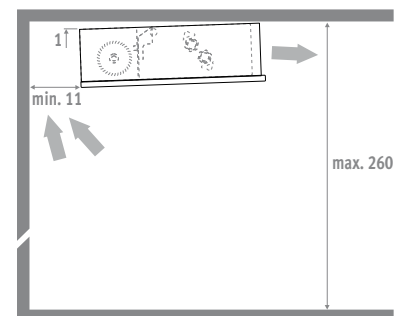
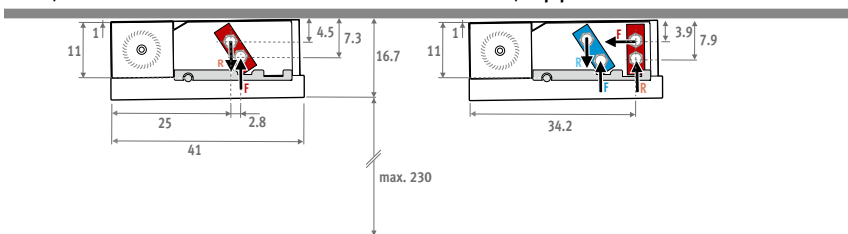

BRIZA 12 BASIC ■ OPTIONS

1. CONNECTION SETS

OPTION 1: CONNECTION SET 24 VDC

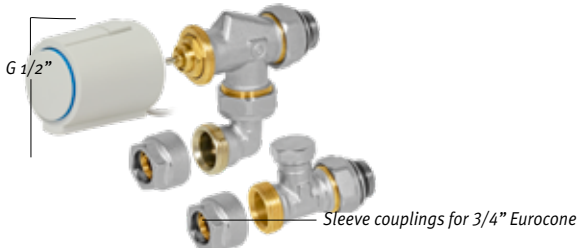

- thermo-electrical motor 24 VDC 0-10V oder 24VDC
- valve 3/4" Eurocone 90°
- lockshield 3/4" Eurocone 180°

Set 295	Kv max. 0.6		
	TWO PIPE		€
CODY.SC5.10.4...	0...10 VDC	228	
CODY.SC5.24.4...	24 VDC	132	

OPTION 2: CONNECTION SET WITH 2 LOCKSHIELDS 180°

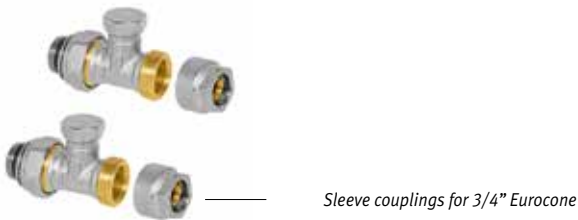

Set 290		€
	CODY.LOC.00.4...	74

SLEEVE COUPLINGS EUROCOONE

Precision metal tube

CODE	Tube
112	12/1
114	14/1
115	15/1
116	16/1
118	18/1

Synthetic or RPE/ALU tube

CODE	Tube	CODE	Tube
612	12/2	619	16/1.5
614	14/2	620	20/2
616	16/2		
618	18/2		

2. POWER SUPPLY

OPTION 1: POWER SUPPLY IN THE DEVICE

- With waterproof cable gland
- CONFORMITY: UL1310 - EN 60950-1 / CLASS 2
- Output voltage 24 VDC
- Input voltage 100 - 240 VAC
- Dimensions L 14.5 x B 4.5 x H 3.0 cm

CODE	Output Watts	Output current A	Surcharge €
/P	40	1.67	119



OPTION 2: POWER SUPPLY DIN-RAIL MOUNTAGE

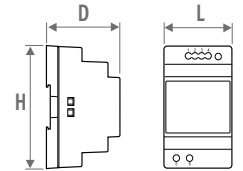

CODE	H	L	D
7990.054	9.0	3.5	5.9
7990.055	9.0	5.3	5.9
7990.056	9.0	7.0	5.9
7990.057	9.0	10.3	5.9

The guarantee is only valid if the original Jaga power supply is used.

- For DIN-rail- or wall mounting
- Conformity: UL60950 / UL508 / IEC 60950-1 / TUV EN61558-2-16 / Class 2
- Output voltage 24 VDC
- Input voltage 100 - 240 VAC
- Screw connection
- LED indicator

MAXIMUM CABLE LENGTH

Maximum cable length in function of the number of devices.
see jaga.com

CODE	Output Watts	Output current A	€
7990.054	36	1.5	48
7990.055	60	2.5	65
7990.056	92	3.9	93
7990.057	150	6.25	187

Required power = sum of the power consumption of the devices

3. THERMOSTATS

OPTION 1: JRT-100TW
NEW: WI-FI THERMOSTAT WITH TOUCH-SCREEN AND APP.

Control per room for one or multiple devices

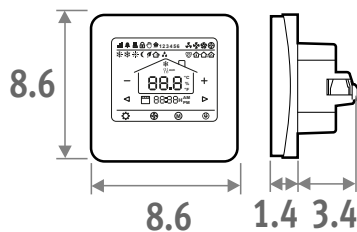

- Jaga clock thermostat for recessed/panel mounting
- Fan speed: 4V/6V/10V or auto
- power supply voltage 24 VDC
Combine with power supply 2.1 or 2.2.
- Output(s) control signal 0-10 VDC
- Programmable zones
- Protection category IP30



Touchscreen



WiFi



App

- LCD touchscreen with background lighting
- control via WIFI (smartphone app)
- programmable time zones 7 days (1-7)
- Control valves 24 VDC heating/cooling
- Thermostat to be mounted in a junction box
 - Spacing holes at 6 cm
 - Minimum depth 4.5 cm
 - inner dimension 5 x 5 cm or Ø 6 cm

CODE			€
8751.050017	Built-in	White	177
8751.050019	Built-in	Black	177



JRT-200



JRT-100



Siemens clock thermostat

Technical data: see jaga.com

4. PRODUCT CONTROLLERS

Recommended if temperature monitoring is required. The fans will never run unless the water temperature is below 18 ° C in cooling mode, or above 28 ° C in heating mode.

OPTION 1:
JAGA DYNAMIC PRODUCT CONTROLLER

The Jaga Dynamic Product Controller is delivered pre-set and mounted in the unit and must therefore be ordered together with the device.



WHAT DOES THE JDPC DO?

- Control per appliance
- Control with sensor for water temperature, pre-configured and assembled by Jaga
- Heating/cooling/standby with automatic switch (temporary manual adjustment is possible: contact Jaga for more information)
- 0-10 V input for building management system/thermostats
- Only for 2 pipe wall mounted model with casing
- Power supply voltage 24 VDC

Delivered preassembled and must therefore be ordered together with the device!

CODE		Surcharge €
DPC.BR72	Heating and cooling	103

OPTION 2: JAGA DYNAMIC PRODUCT CONTROLLER WITH CONTROL PANNEL



WHAT DOES THE JDPC DO?

- Control with touch operation and sensors for water and room temperature, pre-configured and assembled by Jaga
- Heating/cooling/standby with automatic switch (temporary manual adjustment is possible: contact Jaga for more information)
- Control:
 - o Standby
 - o Heating: 3 speeds
(Operates at water temperature > 28°C, can easily be modified)
 - o Cooling: 3 speeds
(Operates at water temperature < 18°C, can easily be modified)
- Indication of operating mode by LED's
- Only for 2 pipe wall mounted model with casing
- power supply voltage 24 VDC

Delivered preassembled and must therefore be ordered together with the device!

CODE		Surcharge
DPC.BRC6	Heating and cooling	130

BRIZA 12 ■ WITH CASING 2-PIPE

STANDARD DELIVERY

- Laquered casing in sendzimir galvanized steel plate with aluminium top grille
- standard colours:
 - traffic white RAL 9016 (133),
Soft touch sanft strukturierte Seidenglanzausführung
 - sandblast grey (001),
fine texture metallic powder coating
 - off-black RAL 7021 (145) Soft touch: finely-textured matte look, gloss degree < 10%
- Other colours: see colour chart
- tangential activators with aluminium fins, ball bearings and resin-coated EPDM vibration damping
- Stainless steel air filter
- Condensation tray with drain
- Copper-aluminum 2-pipe hydrophilic coated heat exchanger, G1/2" F.
- Sturdy casing manufactured from electro-galvanised steel

CONNECTION

- Standard connection:
- Hydraulic connection 3/4" Eurocone left
 - Clamp connector for electric connection 24 VDC, to connect via an external power supply, on the right hand side.
- Other connection:
- Hydraulic right, electric left:
Connection code /70 instead of /20
No surcharge



BZMC Ceiling mounted model



BZMW Wall mounted model

DIMENSIONS			CONTROL VOLTAGE	HEATING ROOM TEMPERATURE 20°C				COOLING TOTAL ROOM TEMPERATURE 27°C		COOLING SENSIBLE ROOM TEMPERATURE 27°C		COOLING Non-condensing ROOM TEMPERATURE 27°C	SOUND PRESSURE*	AIR FLOW	ELECTRIC POWER CONSUMPTION	STANDARD COLOURS	OTHER COLOURS	2-PIPE
H	L	T		U	75/65	55/45	45/35	35/30	7/12	7/12	16/18							
cm	cm	cm	V	Watts	Watts	Watts	Watts	Watts	Watts	Watts								
041	075	12	2	903	542	353	223	285	202	115	19	70	2	878	1191	BZMW.041 075 12.XXX /20		
			4	1035	621	405	255	329	236	135	29	111	3					
			6	1194	717	468	295	383	277	159	31	155	4					
			8	1399	840	548	345	443	325	185	37	196	7					
			10	1669	1002	654	412	505	375	214	43	235	13					
095	12	12	2	1545	927	605	381	473	335	191	24	119	3	959	1272	BZMW.041 095 12.XXX /20		
			4	1699	1020	665	419	531	380	217	30	189	4					
			6	1797	1078	704	443	609	442	252	37	245	7					
			8	2243	1346	878	553	709	520	297	42	315	12					
			10	2749	1650	1076	678	831	617	352	45	380	18					
125	12	12	2	2431	1458	952	599	776	548	313	25	160	3	1188	1501	BZMW.041 125 12.XXX /20		
			4	2717	1630	1064	670	848	607	347	30	243	5					
			6	3090	1854	1210	762	957	693	396	37	328	8					
			8	3617	2170	1416	892	1110	814	465	43	419	14					
			10	4367	2620	1710	1077	1318	978	559	47	492	24					
145	12	12	2	2999	1799	1174	740	1018	720	412	26	190	3	1273	1586	BZMW.041 145 12.XXX /20		
			4	3401	2041	1332	839	1101	788	450	31	295	6					
			6	3894	2337	1525	960	1220	884	505	37	410	10					
			8	4551	2731	1782	1122	1395	1023	584	43	512	19					
			10	5444	3266	2131	1343	1646	1221	698	47	560	29					
055	075	12	2	1400	840	548	345	420	297	170	19	89	2	1127	1440	BZMW.055 075 12.XXX /20		
			4	1701	1021	666	420	523	374	214	25	130	3					
			6	2000	1200	783	493	620	449	256	32	169	6					
			8	2295	1377	899	566	708	519	296	38	212	10					
			10	2588	1553	1013	638	784	581	332	43	250	17					
095	12	12	2	2250	1350	881	555	730	517	295	23	127	2	1249	1562	BZMW.055 095 12.XXX /20		
			4	2781	1668	1089	686	875	626	358	28	193	4					
			6	3309	1985	1295	816	1029	746	426	34	262	6					
			8	3816	2290	1494	941	1176	862	492	40	320	10					
			10	4285	2571	1678	1057	1298	963	550	44	365	16					
125	12	12	2	3561	2136	1394	878	1174	830	474	23	168	3	1555	1869	BZMW.055 125 12.XXX /20		
			4	4420	2652	1731	1090	1391	996	569	29	259	5					
			6	5280	3168	2067	1302	1634	1183	676	37	353	10					
			8	6097	3658	2387	1504	1869	1370	783	43	437	18					
			10	6831	4098	2674	1685	2069	1535	877	47	513	29					
145	12	12	2	4509	2705	1765	1112	1460	1033	590	25	200	3	1694	2008	BZMW.055 145 12.XXX /20		
			4	5525	3315	2163	1363	1734	1242	709	31	297	6					
			6	6588	3953	2579	1625	2037	1476	843	38	396	10					
			8	7615	4569	2981	1878	2332	1710	977	43	500	18					
			10	8526	5115	3338	2103	2584	1917	1095	47	583	29					

Output measured in accordance with EN16430

* Noise measurement according to ISO 3741:2010, 2 m from the device and with an assumed room attenuation of 8 dB(A) / room volume 100 m³ / reverberation time 0.5 sec.

BZMW (Wall mounted model)
BZMC (Ceiling mounted model)

enter colour
code

WITH CASING 4-PIPE BRIZA 12

STANDARD DELIVERY

- Laquered casing in sendzimir galvanized steel plate with aluminium top grille
- standard colours:
 - traffic white RAL 9016 (133), soft touch lightly structured satin powder coating
 - sandblast grey (001), fine texture metallic powder coating
 - off-black RAL 7021 (145) Soft touch: finely-textured matte look, gloss degree < 10%
- Other colours: see colour chart
- tangential activators with aluminium fins, ball bearings and resin-coated EPDM vibration damping
- Stainless steel air filter
- Condensation tray with drain
- Copper-aluminum 2-pipe hydrophilic coated heat exchanger, G1/2" F.
- Second heat exchanger, G1/2" F
- Sturdy casing manufactured from electro-galvanised steel

CONNECTION

- Standard connection:
- Hydraulic connection 3/4" Eurocone left
 - Clamp connector for electric connection 24 VDC, to connect via an external power supply, on the right hand side.
- Other connection:
Hydraulic right, electric left:
Connection code /70 instead of /20
No surcharge.



BZMC Ceiling mounted model



BZMW Wall mounted model

DIMENSIONS			CONTROL VOLTAGE	HEATING ROOM TEMPERATURE 20°C				COOLING TOTAL ROOM TEMPERATURE 27°C		COOLING SENSIBLE ROOM TEMPERATURE 27°C	COOLING (Non-condensing) ROOM TEMPERATURE 27°C	SOUND PRESSURE*	AIR FLOW	ELECTRIC POWER CONSUMPTION	STANDARD COLOURS	OTHER COLOURS	4-PIPE
H	L	T		75/65	55/45	45/35	35/30	7/12	7/12	16/18	dB(A)						
cm	cm	cm	V	Watts	Watts	Watts	Watts	Watts	Watts	Watts							
041	075	12	2	698	419	273	172	229	162	92	19	32	2	1017	1330	BZMW.041 075 12.XXX /4/20	
			4	840	504	329	207	267	191	109	29	67	3				
			6	948	569	371	234	310	224	128	31	95	5				
			8	1120	672	438	276	355	260	149	37	128	8				
			10	1336	802	523	330	403	299	171	43	157	14				
095	12	12	2	1211	726	474	299	365	258	148	24	57	2	1117	1431	BZMW.041 095 12.XXX /4/20	
			4	1349	810	528	333	432	309	177	30	101	3				
			6	1529	918	599	377	493	357	204	37	158	6				
			8	1797	1078	704	443	566	415	237	42	213	8				
			10	2200	1320	861	543	664	493	282	45	252	14				
125	12	12	2	1924	1155	753	475	594	420	240	25	80	2	1418	1732	BZMW.041 125 12.XXX /4/20	
			4	2163	1298	847	533	676	484	276	30	164	4				
			6	2470	1482	967	609	767	556	318	37	242	7				
			8	2896	1738	1134	714	887	651	372	43	305	13				
			10	3492	2095	1367	861	1055	782	447	47	400	21				
145	12	12	2	2380	1428	932	587	720	509	291	26	98	3	1532	1846	BZMW.041 145 12.XXX /4/20	
			4	2722	1633	1066	671	843	603	345	31	174	5				
			6	3119	1872	1221	769	967	701	400	37	249	9				
			8	3641	2185	1426	898	1118	819	468	43	318	17				
			10	4355	2613	1705	1074	1316	976	558	47	420	29				
055	075	12	2	610	366	239	150	341	241	138	19	30	2	1229	1543	BZMW.055 075 12.XXX /4/20	
			4	696	418	272	172	398	285	163	25	74	2				
			6	778	467	305	192	466	337	193	32	118	4				
			8	923	554	361	228	533	390	223	38	151	6				
			10	1102	661	431	272	588	436	249	43	188	10				
095	12	12	2	1000	600	391	247	557	394	225	23	79	2	1377	1690	BZMW.055 095 12.XXX /4/20	
			4	1115	669	437	275	656	470	268	28	135	3				
			6	1250	750	489	308	767	556	318	34	185	6				
			8	1480	888	579	365	876	643	367	40	251	10				
			10	1813	1088	710	447	973	721	412	44	282	16				
125	12	12	2	1570	942	615	387	868	614	351	23	123	2	1694	2008	BZMW.055 125 12.XXX /4/20	
			4	1798	1079	704	444	1042	746	426	29	201	4				
			6	2040	1224	799	503	1229	890	509	37	286	8				
			8	2399	1440	939	592	1406	1031	589	43	360	13				
			10	2879	1727	1127	710	1551	1151	658	47	423	22				
145	12	12	2	1980	1188	775	488	1130	799	457	25	139	3	1862	2176	BZMW.055 145 12.XXX /4/20	
			4	2245	1347	879	554	1307	935	534	31	251	5				
			6	2565	1539	1004	633	1526	1106	632	38	334	9				
			8	2996	1797	1173	739	1748	1282	732	43	432	16				
			10	3591	2154	1406	886	1935	1435	820	47	508	27				

Output measured in accordance with EN16430

* Noise measurement according to ISO 3741:2010, 2 m from the device and with an assumed room attenuation of 8 dB(A) / room volume 100 m³ / reverberation time 0.5 sec.

BZMW (Wall mounted model)
BZMC (Ceiling mounted model)

enter
colour code

BRIZA 12 ■ BUILT-IN 2-PIPE

STANDARD DELIVERY

- tangential activators with aluminium fins, ball bearings and resin-coated EPDM vibration damping
- Stainless steel air filter
- Condensation tray with drain
- Copper-aluminum 2-pipe hydrophilic coated heat exchanger, G1/2" F.
- Sturdy casing manufactured from electro-galvanised steel

CONNECTION

- Standard connection:
- Hydraulic connection 3/4" Eurocone left
 - Clamp connector for electric connection 24 VDC, to connect via an external power supply, on the right hand side.
- Other connection:
Hydraulic right, electric left:
Connection code /70 instead of /20
No surcharge.



BZBC Built-in ceiling



BZBW Installation in a wall recess

DIMENSIONS			CONTROL VOLTAGE	HEATING ROOM TEMPERATURE 20°C				COOLING TOTAL ROOM TEMPERATURE 27°C		COOLING SENSIBLE ROOM TEMPERATURE 27°C	COOLING (Non-condensing) ROOM TEMPERATURE 27°C	SOUND PRESSURE*	AIR FLOW	ELECTRIC POWER CONSUMPTION	PRICE	2-PIPE
H	L	T		U	75/65	55/45	45/35	35/30	7/12	7/12	16/18					
cm	cm	cm	V	Watts	Watts	Watts	Watts	Watts	Watts	Watts						
038	052	12	2	1000	600	392	247	280	198	113	19	70	2	752	BZBW.038 052 12./20	
			4	1150	690	450	284	348	249	142	25	111	3			
			6	1310	786	513	323	417	302	172	33	155	4			
			8	1530	918	599	377	486	356	203	39	196	7			
			10	1836	1102	719	453	555	412	235	44	235	13			
072	12	2	1619	971	634	399	489	346	198	22	119	3	818	BZBW.038 072 12./20		
		4	1982	1189	776	489	572	409	234	28	189	4				
		6	2099	1259	822	518	670	485	277	35	245	7				
		8	2461	1476	963	607	784	575	329	41	315	12				
		10	3021	1813	1183	745	914	678	387	45	380	18				
102	12	2	2604	1562	1020	642	807	571	326	23	160	3	1018	BZBW.038 102 12./20		
		4	3192	1915	1250	787	903	646	369	30	243	5				
		6	3409	2045	1335	841	1043	755	432	38	328	8				
		8	3995	2397	1564	986	1226	898	513	44	419	14				
		10	4799	2879	1879	1184	1450	1075	615	49	492	24				
122	12	2	3273	1964	1282	808	971	686	392	26	190	3	1088	BZBW.038 122 12./20		
		4	4023	2414	1575	992	1033	739	423	31	295	6				
		6	4297	2578	1683	1060	1271	921	526	38	410	10				
		8	5021	3013	1966	1239	1565	1147	656	44	512	19				
		10	5983	3590	2342	1476	1801	1336	763	48	560	29				
052	052	12	2	1500	900	587	370	462	327	187	21	89	2	973	BZBW.052 052 12./20	
			4	1751	1050	685	432	543	388	222	27	130	3			
			6	2109	1266	826	520	643	466	266	34	169	6			
			8	2400	1440	940	592	756	554	317	40	212	10			
			10	2717	1630	1064	670	823	611	349	44	250	17			
072	12	2	2465	1479	965	608	790	559	319	22	127	2	1088	BZBW.052 072 12./20		
		4	2931	1759	1148	723	922	660	377	27	193	4				
		6	3499	2099	1370	863	1073	778	444	35	262	6				
		8	4011	2406	1570	989	1226	899	513	41	320	10				
		10	4499	2699	1761	1110	1362	1010	577	45	365	16				
102	12	2	3895	2337	1525	961	1257	889	508	24	168	3	1355	BZBW.052 102 12./20		
		4	4651	2791	1821	1147	1455	1041	595	30	259	5				
		6	5549	3329	2172	1369	1709	1238	708	38	353	10				
		8	6391	3834	2502	1577	1966	1441	823	44	437	18				
		10	7172	4303	2808	1769	2171	1610	920	48	513	29				
122	12	2	4652	2791	1821	1148	1550	1096	627	26	200	3	1481	BZBW.052 122 12./20		
		4	5794	3476	2268	1429	1823	1305	746	32	297	6				
		6	6924	4154	2711	1708	2149	1557	890	39	396	10				
		8	7994	4796	3130	1972	2439	1788	1022	45	500	18				
		10	8954	5373	3506	2209	2711	2011	1149	49	583	29				

Output measured in accordance with EN16430

* Noise measurement according to ISO 3741:2010, 2 m from the device and with an assumed room attenuation of 8 dB(A) / room volume 100 m³ / reverberation time 0.5 sec.

BZBW (Installation in a wall recess)
BZBC (Built-in ceiling)

BUILT-IN 4-PIPE ■ BRIZA 12

STANDARD DELIVERY

- tangential activators with aluminium fins, ball bearings and resin-coated EPDM vibration damping
- Stainless steel air filter
- Condensation tray with drain
- Copper-aluminum 2-pipe hydrophilic coated heat exchanger, G1/2" F.
- Second heat exchanger, G1/2" F
- Sturdy casing manufactured from electro-galvanised steel

CONNECTION

- Standard connection:
- Hydraulic connection 3/4" Eurocone left
 - Clamp connector for electric connection 24 VDC, to connect via an external power supply, on the right hand side.
- Other connection:
Hydraulic right, electric left:
Connection code /70 instead of /20
No surcharge



BZBC Built-in ceiling



BZBW Installation in a wall recess

DIMENSIONS			CONTROL VOLTAGE	HEATING ROOM TEMPERATURE 20°C				COOLING TOTAL ROOM TEMPERATURE 27°C		COOLING SENSIBLE ROOM TEMPERATURE 27°C	COOLING (Non-condensing) ROOM TEMPERATURE 27°C	SOUND PRESSURE*	AIR FLOW	ELECTRIC POWER CONSUMPTION	PRICE	4-PIPE
H	L	T		U	75/65	55/45	45/35	35/30	7/12	7/12						
cm	cm	cm	V	Watts	Watts	Watts	Watts	Watts	Watts	Watts						
038	052	12	2	799	480	313	197	248	175	100	19	32	2	891	BZBW.038 052 12./4/20	
			4	918	551	359	226	292	209	119	25	67	3			
			6	1053	632	412	260	339	246	140	33	95	5			
			8	1228	737	481	303	390	286	163	39	128	8			
			10	1468	881	575	362	443	329	188	44	157	14			
072	12	2	1343	806	526	331	407	288	165	22	57	2	978	BZBW.038 072 12./4/20		
		4	1497	898	586	369	469	336	192	28	101	3				
		6	1681	1009	658	415	537	389	222	35	158	6				
		8	1965	1179	769	485	621	455	260	41	213	8				
		10	2417	1450	946	596	731	542	310	45	252	14				
102	12	2	2102	1261	823	518	668	472	270	23	80	2	1243	BZBW.038 102 12./4/20		
		4	2395	1437	938	591	744	533	305	30	164	4				
		6	2731	1638	1069	673	841	609	348	38	242	7				
		8	3186	1912	1247	786	974	714	408	44	305	13				
		10	3839	2303	1503	947	1160	860	492	49	400	21				
122	12	2	2606	1564	1020	643	821	580	332	26	98	3	1349	BZBW.038 122 12./4/20		
		4	2998	1799	1174	739	930	666	380	31	174	5				
		6	3431	2059	1343	846	1057	766	438	38	249	9				
		8	3997	2398	1565	986	1222	896	512	44	318	17				
		10	4787	2872	1874	1181	1444	1071	612	48	420	29				
052	052	12	2	640	384	251	158	354	251	143	21	30	2	1075	BZBW.052 052 12./4/20	
			4	725	435	284	179	414	296	169	27	74	2			
			6	830	498	325	205	491	356	203	34	118	4			
			8	969	582	379	239	554	406	232	40	151	6			
			10	1157	694	453	285	618	458	262	44	188	10			
072	12	2	1050	630	411	259	577	408	233	22	79	2	1215	BZBW.052 072 12./4/20		
		4	1176	706	461	290	687	492	281	27	135	3				
		6	1314	789	515	324	808	585	334	35	185	6				
		8	1550	930	607	382	925	678	387	41	251	10				
		10	1903	1142	745	469	1022	758	433	45	282	16				
102	12	2	1650	990	646	407	945	668	382	24	123	2	1494	BZBW.052 102 12./4/20		
		4	1891	1134	740	466	1098	786	449	30	201	4				
		6	2150	1290	842	530	1291	936	535	38	286	8				
		8	2503	1502	980	617	1467	1075	615	44	360	13				
		10	3023	1814	1184	746	1629	1208	690	48	423	22				
122	12	2	2002	1201	784	494	1151	814	465	26	139	3	1649	BZBW.052 122 12./4/20		
		4	2362	1417	925	583	1372	982	561	32	251	5				
		6	2700	1620	1057	666	1610	1166	666	39	334	9				
		8	3152	1891	1234	777	1839	1348	770	45	432	16				
		10	3769	2261	1476	930	2033	1508	862	49	508	27				

Output measured in accordance with EN16430

* Noise measurement according to ISO 3741:2010, 2 m from the device and with an assumed room attenuation of 8 dB(A) / room volume 100 m³ / reverberation time 0.5 sec.

BZBW (Installation in a wall recess)
BZBC (Built-in ceiling)

BRIZA 12 ■ INSTALLATION SCHEMES ■ PLUG & PLAY

Heat pump and Briza Plug & Play with integrated Wi-Fi room thermostat and electrically controlled valves.

Temperature control in every unit/room via the integrated room thermostat. The heat pump works autonomously and supplies water according to the weather conditions.

Example

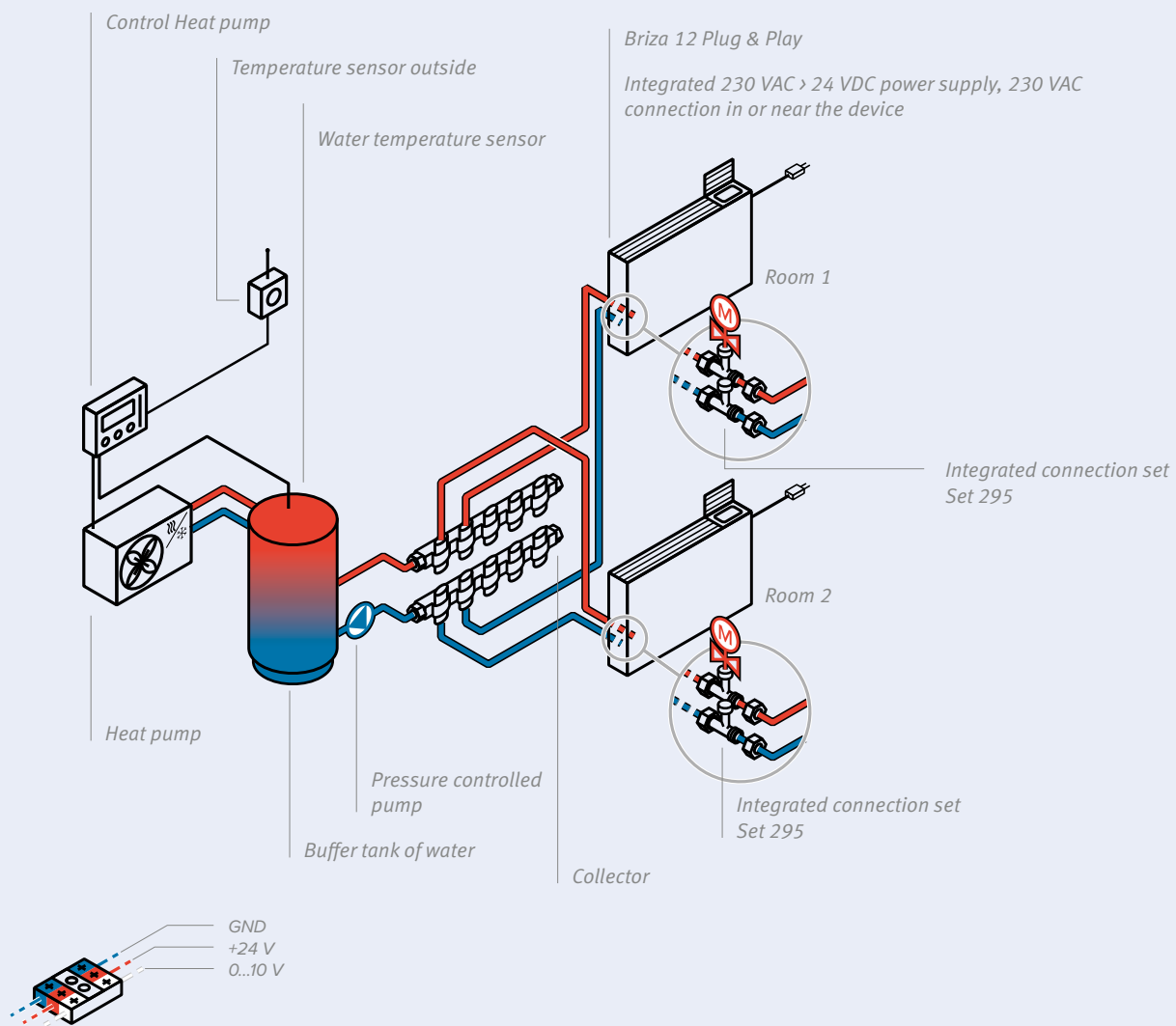

BASIC ■ INSTALLATION SCHEMES ■ BRIZA 12

Heat pump and Briza BASIC (24 VDC) with external room thermostat and external fan control.

The external room thermostat manages the Briza's fan speed via a 0-10 V signal and controls the electrically controlled valves on the distributor (open/closed) in order to switch between heating and cooling. The heat pump works autonomously and supplies water according to the weather conditions.

Example

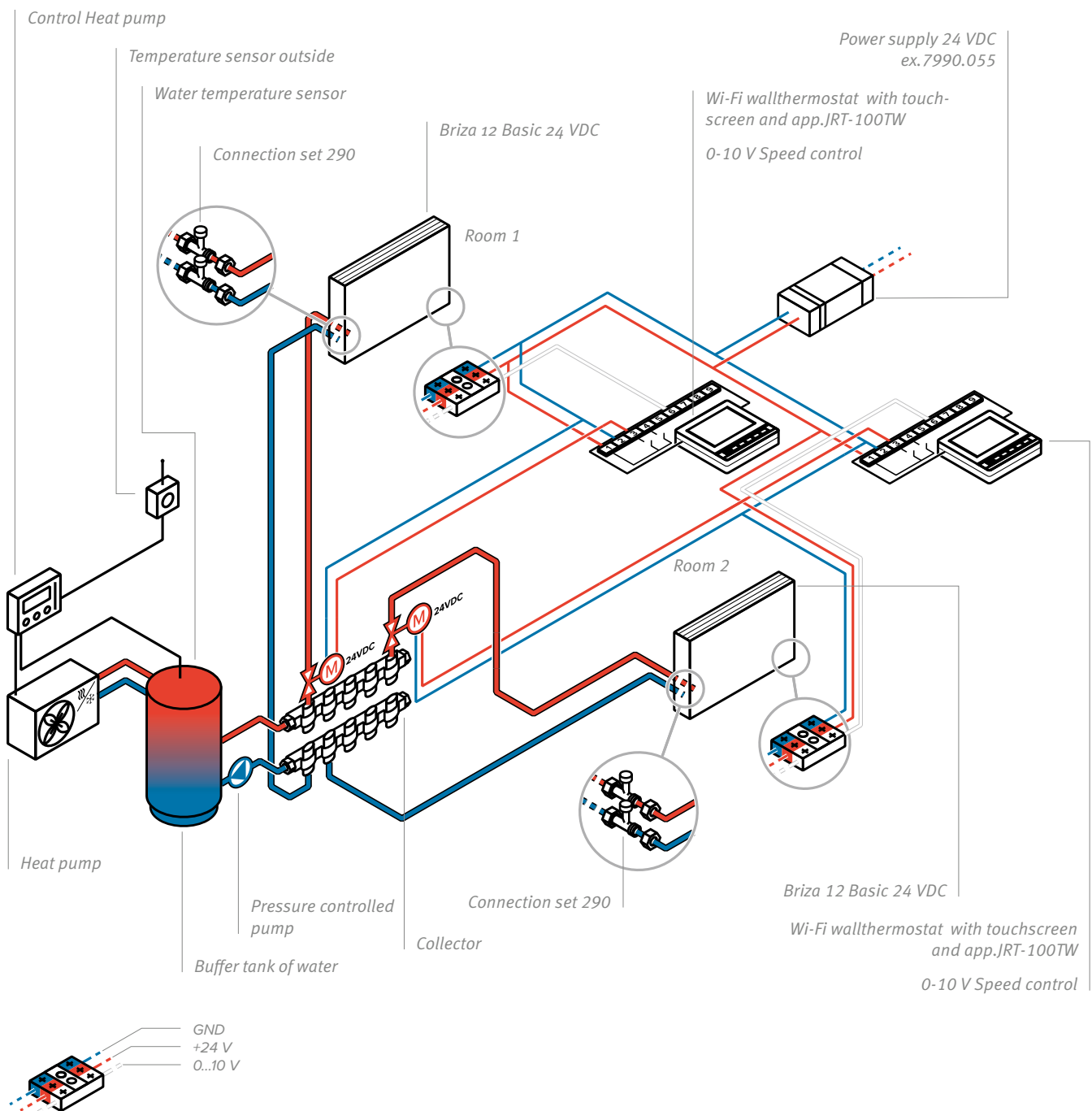

BRIZA 12 ■ INSTALLATION SCHEMES ■ BASIC

Heat pump and Briza BASIC (24VDC) with external room thermostat, external fan control and integrated water temperature monitoring.

Heat pump and Briza Basic (24V) with JDPC option, used with an external room thermostat. The external room thermostat adjusts the Briza's fan speed via a 0-10V signal. The JDPC option (for mounted Jaga Dynamic Product Controller) provides water temperature monitoring and possible fan speed adjustment. The heat pump supplies water according to the room thermostat's heating/ cooling demand.

Example

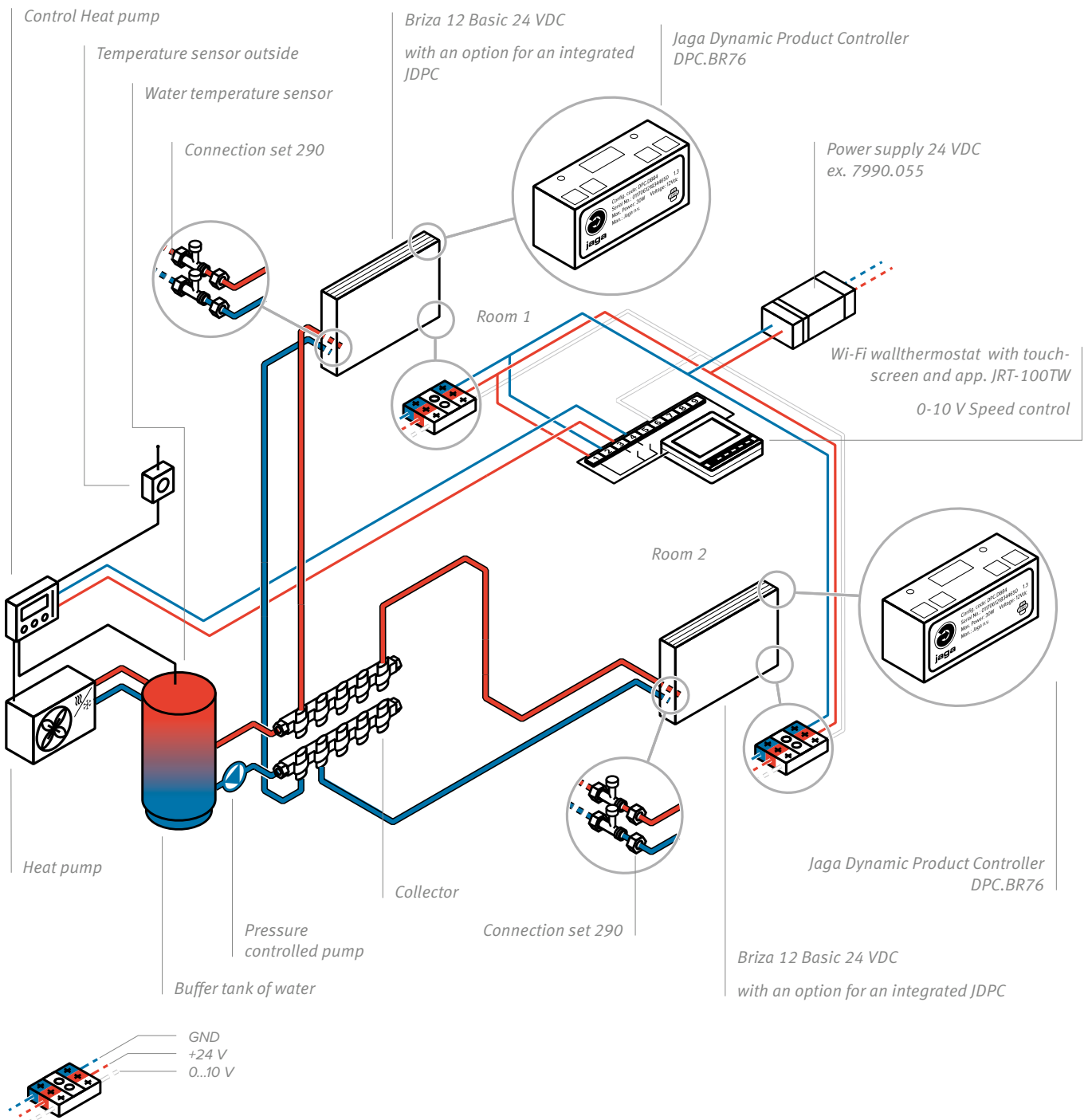

BASIC ■ INSTALLATION SCHEMES ■ BRIZA 12

Heat pump and Briza BASIC (24 VDC) with preassembled JDPC with control panel (option)

Integrated electronic JDPC unit with water temperature monitoring and a 3-position control of the fan speed with a control panel on the device. The Briza will start up when warm or cold water enters the heat exchanger, which is controlled by a heat pump with thermostatic control.

Example

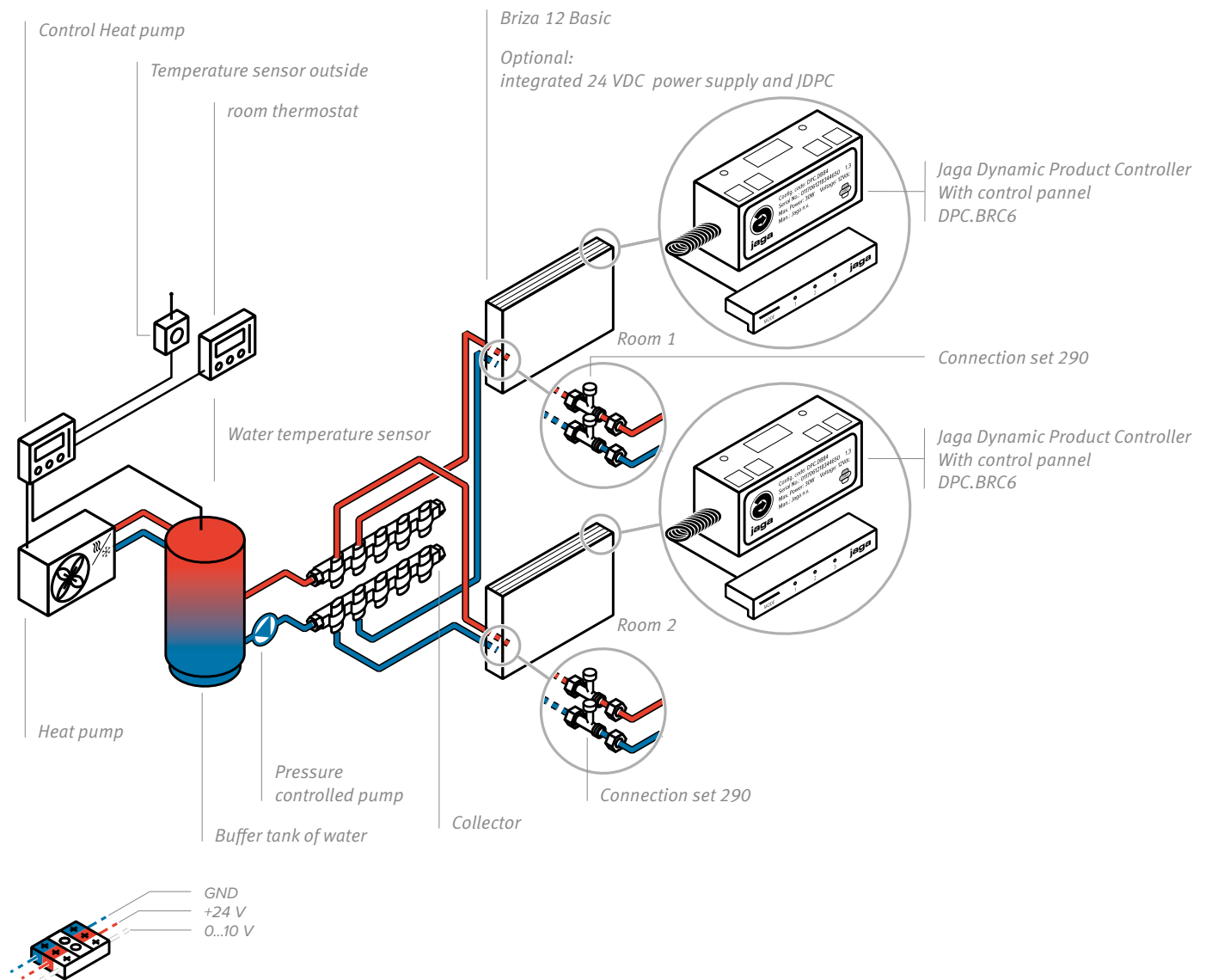

BRIZA 22

Easy to install fan convector for in-wall or in-ceiling installation

Super-power for heating, cooling and ventilation

Briza 22 is the most powerful ventilo-convector for exhibition and retail spaces, office and meeting rooms, school buildings, hotels, winter gardens, etc. Jaga Briza fan convectors ensure the highest climate comfort while being energy-efficient and whisper-quiet. They bring every room up to temperature very quickly, both in winter and in summer. This way you can enjoy an ideal indoor climate year-round.

- Built-in EC motor for a much lower energy consumption and a longer service life, suitable for connection to any heat source and ideal in combination with heat pumps and low temperature systems, optimized cooling capacity due to the new hydrophilic protection of the copper-aluminum coil, suitable for non-condensing and condensing cooling in combination with any heat pump that has a cooling function, with built-in room thermostat or controllable via the latest home automation systems, two-pipe system for cooling or heating through a single water-side circuit, 4-pipe system for cooling and heating through two water-side circuits.
- For 2-pipe or 4-pipe
- Also available for in-ceiling installation.



EBM-PAPST motors with Energy Efficiency Award





BRIZA 22

BRIZA 22 ■ BUILT-IN (BABW - BABC)



Heat exchanger with hydrophilic coating for optimum cooling performance

Hydraulic connection
2-pipe G3/4"
4-pipe G1/2"

Sturdy casing manufactured from electro-galvanised steel

Metal condensate tray with epoxy-polyester coating

Centrifugal fan(s) with twin inlet



Electrical connection

Filter Class G2

Mounting of the fan blade using dust/oil-free ball bearings

Greentech EC motor 230 VAC 0-10V



GREENTECH EC-MOTORS

EC motors reduce operating costs, reduce the impact on the environment and impress with their quiet operation. Due to the higher efficiency of the EC motors, the energy consumption is directly linked to the rotation speed and thus the flow rate of the fan. The actual power consumption is determined by the (variable) speed.

INSTALLATION IN A WALL RECESS BABW

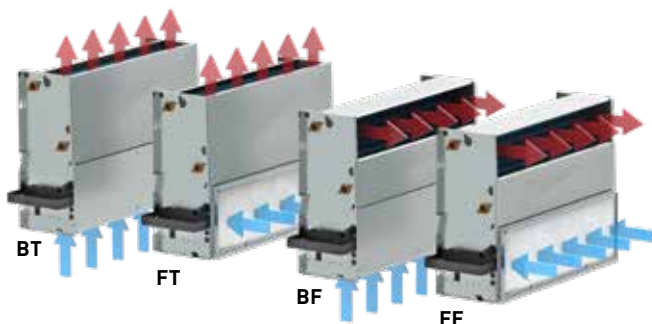

BUILT-IN CEILING BABC

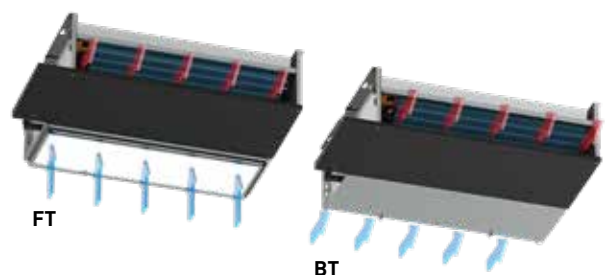



back panel to aesthetically seal off the space between the radiator and the wall
 - prepainted in dark gray RAL 7024

aluminium top grille, powder coated in the same colour as the unit

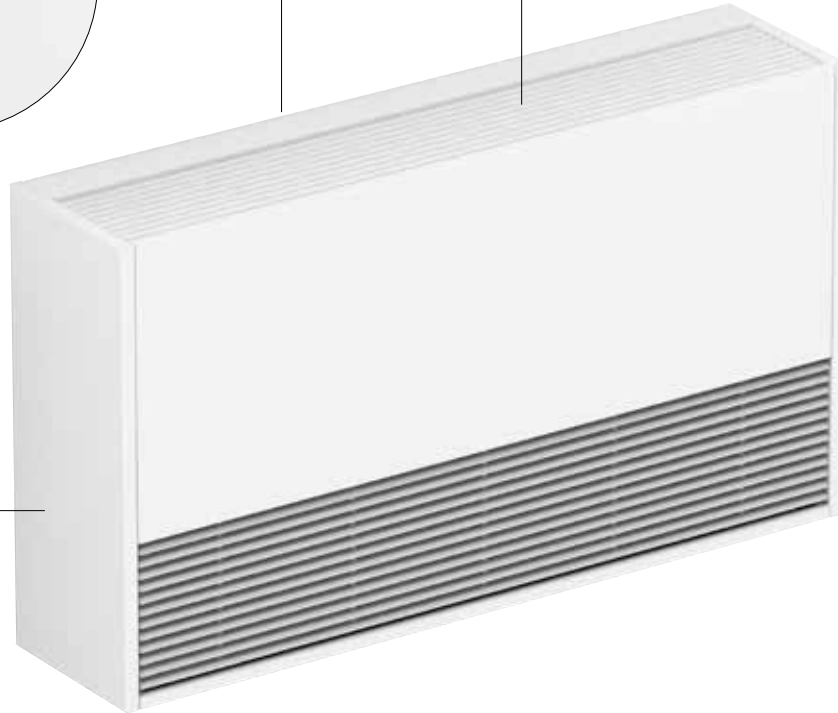

Laquered casing in sendzimir galvanized steel plate
 standard colours:
 - traffic white RAL 9016 (133), soft touch lightly structured satin powder coating
 - sandblast grey (001), fine texture metallic powder coating
 - off-black (145), soft touch lightly-textured satin lacquer
 Other colours: see colour chart

EASY INSTALLATION

The units are light and compact. In order to facilitate the installation, the construction is done with an eye for detail. Despite its small dimensions, there is sufficient space for connecting and installing additional components.

WALL MOUNTED MODEL BAMW

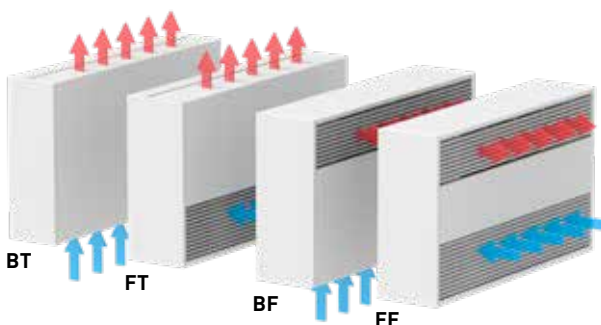

CEILING MOUNTED MODEL BAMC

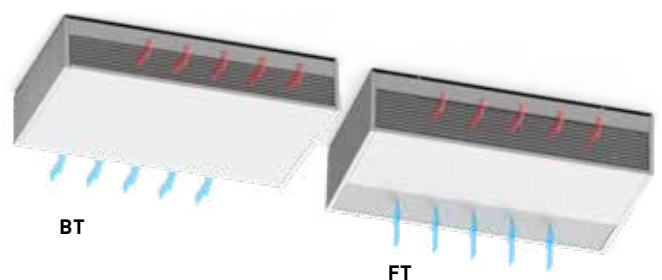

BRIZA 22 ■ INSTALLATION IN A WALL RECESS - BABW

DIMENSIONS (in cm)

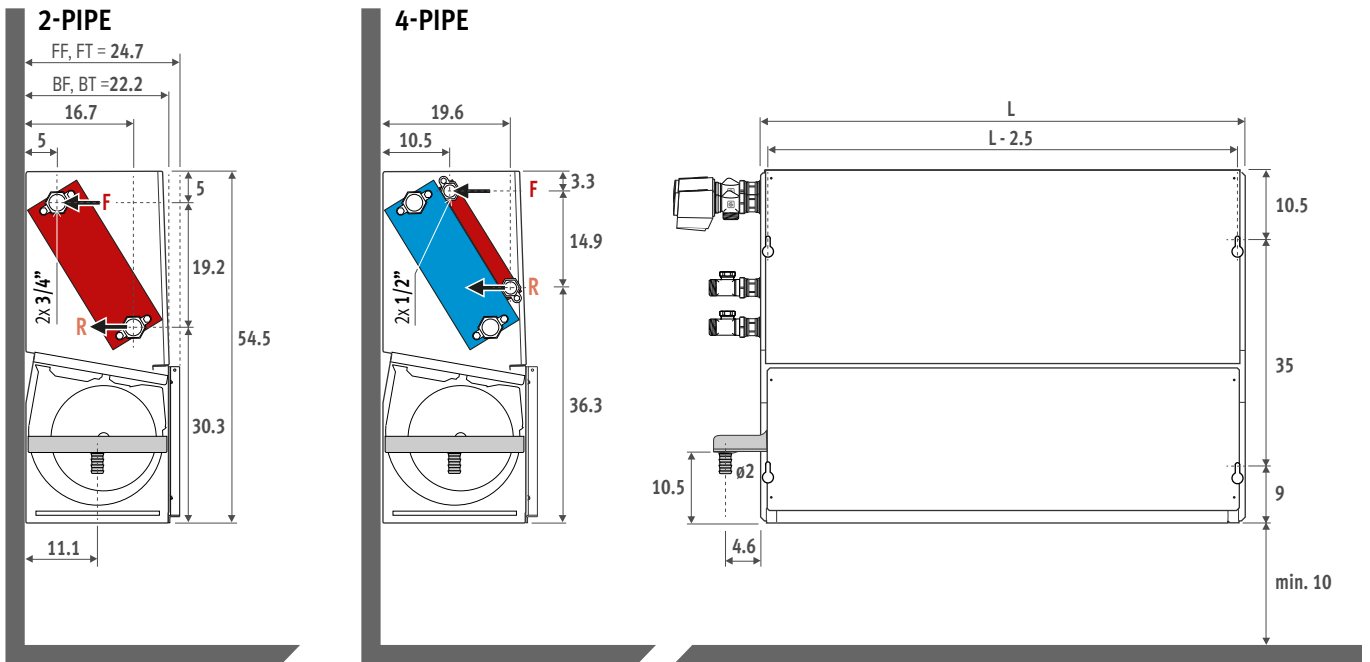

INSTALLATION

BT • BOTTOM TOP

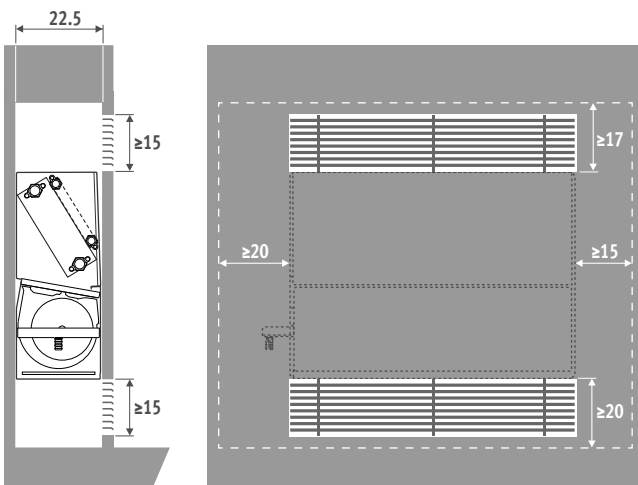

FT • FRONT TOP

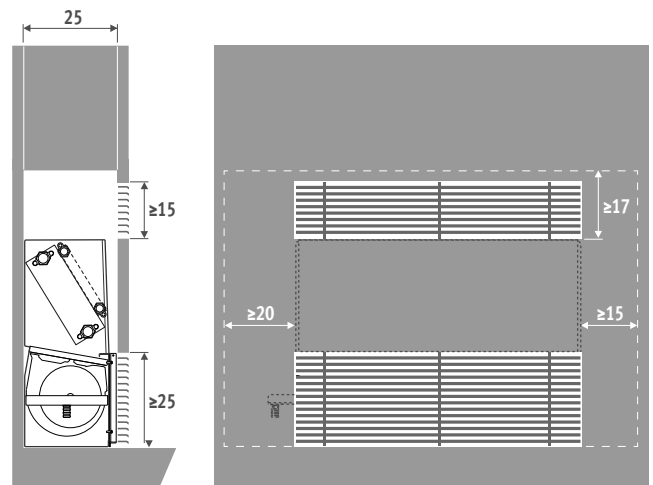

BF • BOTTOM FRONT

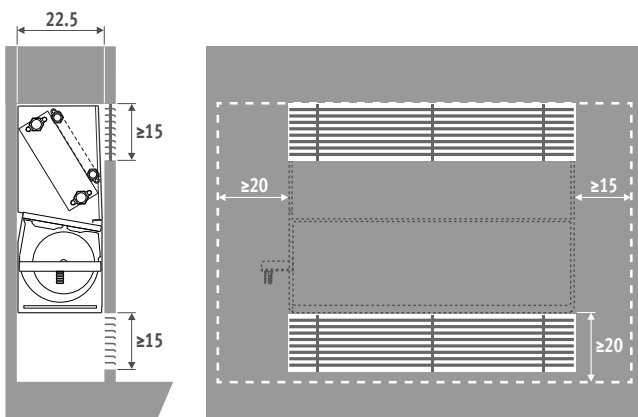

FF • FRONT FRONT

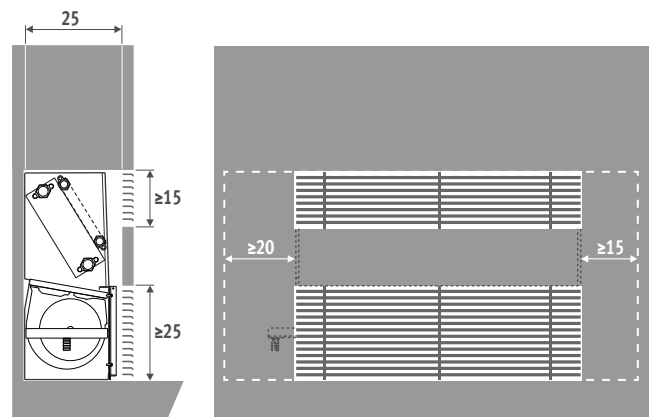

BUILT-IN CEILING - BABC ■ BRIZA 22

DIMENSIONS (in cm)

2-PIPE

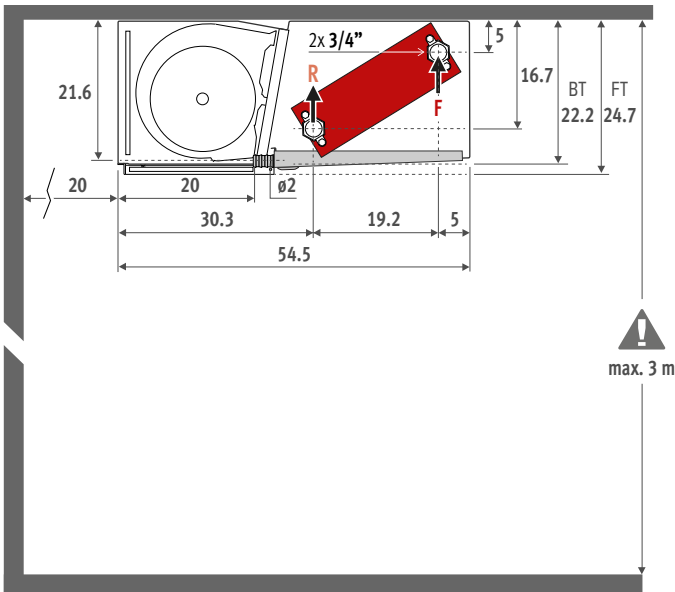

4-PIPE

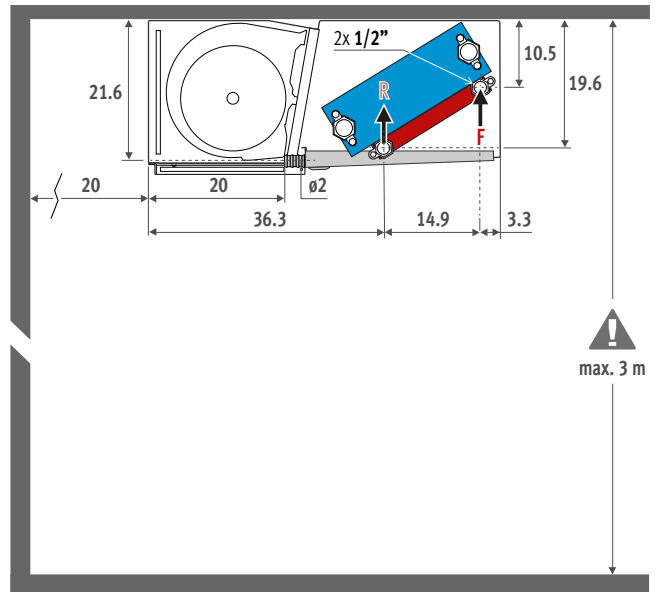

INSTALLATION

BT - BOTTOM TOP

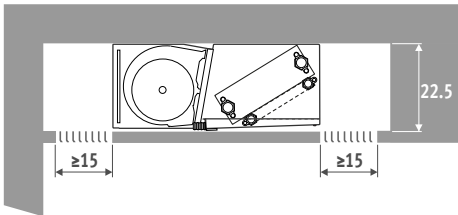

FT - FRONT TOP

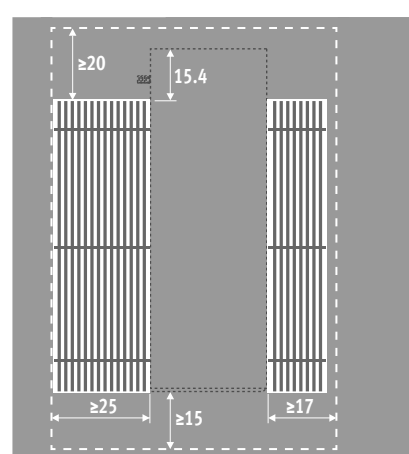
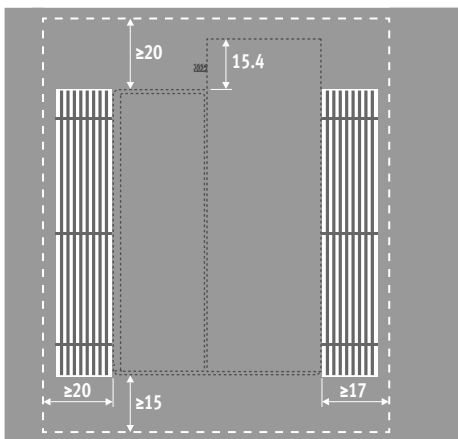
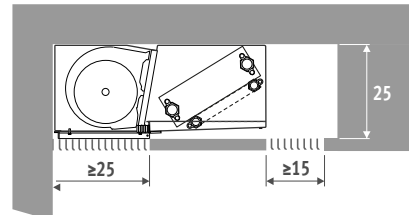

BRIZA 22 ■ WALL MOUNTED MODEL WITH CASING - BAMW

DIMENSIONS (in cm)

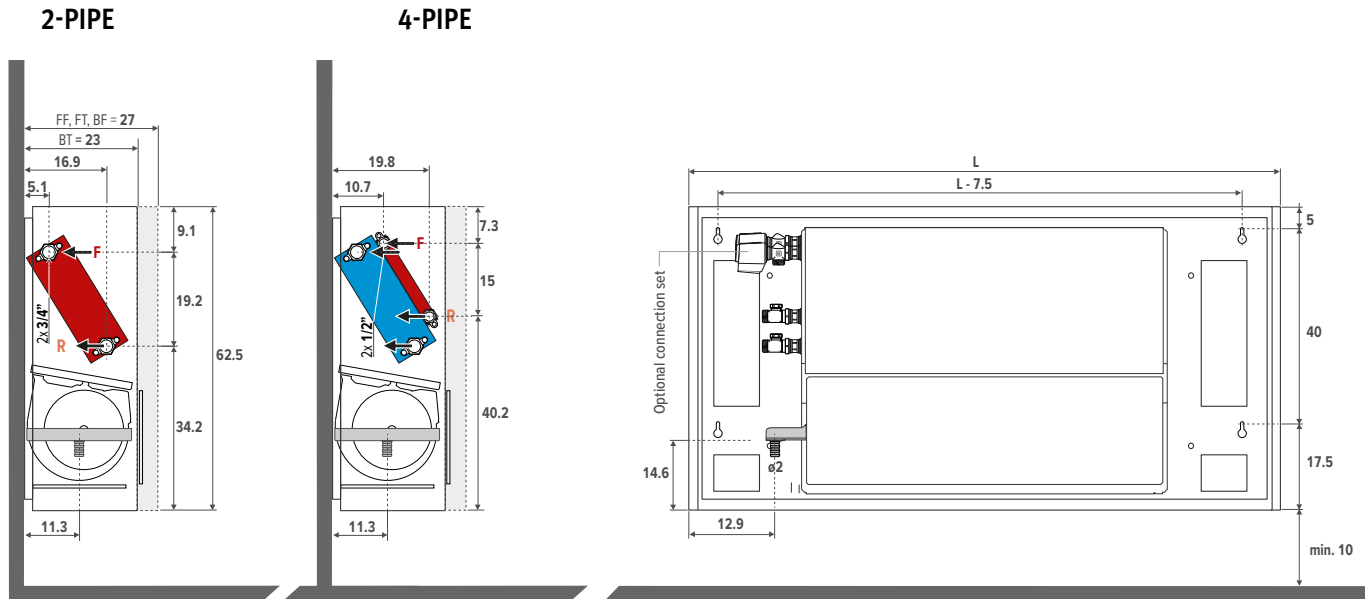

BRIZA 22 ■ CEILING MOUNTED MODEL WITH CASING - BAMC

DIMENSIONS (in cm)

2-PIPE

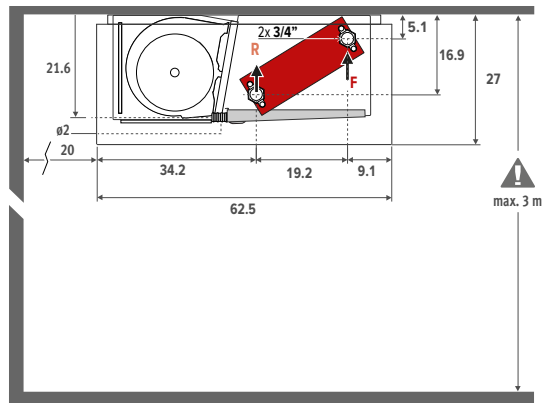

4-PIPE

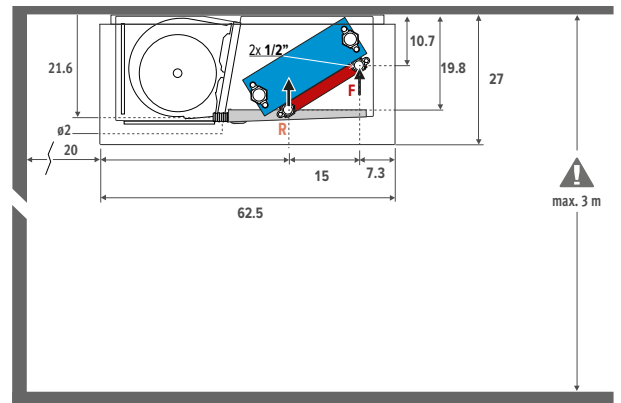

PRE-MOUNTED JAGA FANCOIL CONTROLLER (JFCC)

Jaga Fan Coil Controller increases the functionalities of the Jaga products. The JFCC is available for all Jaga Briza 22 devices. The controller is delivered pre-set and mounted in the unit. The device is controlled by the home automation system or BMS.



CONTROL VIA BMS OR EXTERNAL THERMOSTAT

- For 2-pipe or 4-pipe
- Control per appliance, without control panel
- With water temperature sensor
- Power supply 230 VAC
- With key card contact / window contact
- Heating / cooling
- Heating: configured at water temperature >28°C, can easily be modified
- Cooling: configured at water temperature <18°C, can easily be modified
- 0-10 V input for building management system/thermostats

CODE	SURCHARGE	€
FCC.BR712 Heating 2-pipe	347	
FCC.BR722 Heating / Cooling 2-pipe	347	
FCC.BR724 Heating / Cooling 4-pipe	347	

CONTROL WITH 3-POSITION CONTROL PANEL

- For 2-pipe or 4-pipe
- Control with a pushbutton control and a water and room temperature sensor(s)
- Heating/cooling with automatic switch
- Power supply 230 VAC
- With key card contact / window contact
- Heating: configured at water temperature >28°C, can easily be modified
- Cooling: configured at water temperature <18°C, can easily be modified

CODE	SURCHARGE	€
FCC.BRC42 Heating 2-pipe	358	
FCC.BRC62 Heating / Cooling 2-pipe	358	
FCC.BRC64 Heating / Cooling 4-pipe	358	

CLOCK THERMOSTATS HEATING / COOLING

The features in bold type listed below apply to thermostats 8751.050013 - 8751.050012 - 8751.050009

- Automatic thermostat for
 - . 2-pipe: heating/cooling or auto
 - . 4-pipe: heating/cooling or auto
- Fan speed: 4V/6V/10V or auto
- power supply voltage 24 VDC
- Output(s) control signal 0-10 VDC
- 1 clock thermostat per room
- Programmable zones
- LCD display with background lighting
- Protection category IP30

FOR WALL MOUNTING

Jaga clock thermostat for wall mounting JRT-200

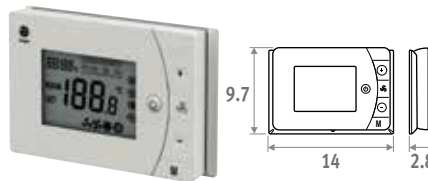

- 2 potential-free contacts heating/cooling (f.e. valve control 24 VDC or 230 VAC)
- With key card contact / window contact
- Can be mounted on a junction box with screw holes at 6 cm

CODE	€
8751.050013 Wall mounted	100

Siemens clock thermostat for wall mounting

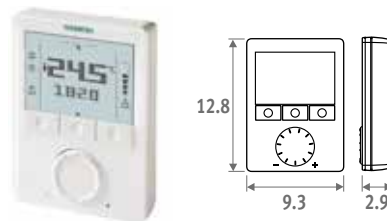

- Unlimited adjustment possibilities: 74 features and diagnostic test
- Contact Jaga for more information

CODE	€
8751.050009 Wall mounted	315

FOR RECESSED MOUNTING

NEW

Jaga clock thermostat for recessed/panel mounting JRT-100TW

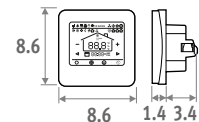

Touchscreen



Wi-Fi



App

- LCD touchscreen with background lighting
- control via WIFI (smartphone app)
- programmable time zones 7 days(1-7)
- Control valves 24 VDC heating/cooling
- Thermostat to be mounted in a junction box
- Spacing holes at 6 cm
- Minimum depth 4.5 cm
- inner dimension 5 x 5 cm or Ø 6 cm

CODE	€
8751.050017 Built-in White	177
8751.050019 Built-in Black	177

Jaga clock thermostat for recessed/panel mounting JRT-100



- Control valves 24 VDC heating/cooling
- Thermostat to be mounted in a junction box
- Spacing holes at 6 cm
- Minimum depth 4.5 cm
- inner dimension 5 x 5 cm or Ø 6 cm

CODE	€
8751.050012 Built-in	106

BRIZA 22 - OPTIONS



FILTER

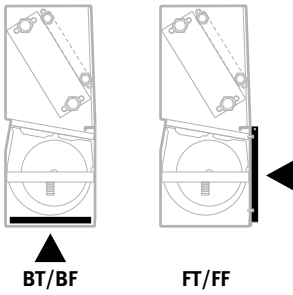

- Filter Class G2
- Fire-safe according to DIN 53438 (F1)

CODE	Length Briza 22	€
8721.401	55	43
8721.402	75	49
8721.403	95	55
8721.404	125	72
8721.405	155	84

CONNECTION SET 2-PIPE JAGA 3/4 DN20

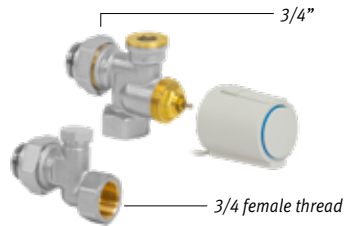
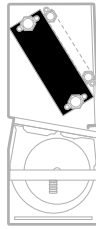

- Thermoelectric motor 24 VDC or 230VAC
- valve Eurocone 3/4" x 3/4"
- lockshield Eurocone 3/4" x 3/4"

Set 301	Kv max. 0.8-2.5	TWO PIPE	€
CODY.WA5.24.0	24 VDC	108	
CODY.WA5.23.0	230 VAC	108	

CONNECTION SET WITH 2 LOCKSHIELDS 3/4 180°

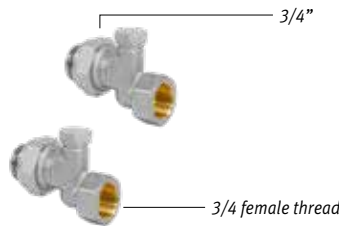

Set 302	€
CODY.LO5.00.0	52

CONNECTION SET 4-PIPE JAGA 1/2

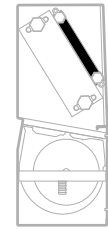

Only to be used with Briza 22 4-pipe.

To be mounted on the 2nd heat exchanger with 1/2 "connections.

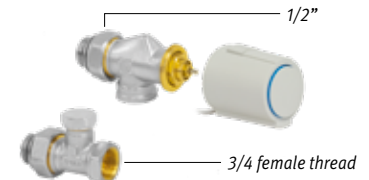

- Thermoelectric motor 24 VDC or 230VAC
- valve G1/2" x G1/2" 90°
- lockshield G1/2" x G1/2" 180°

Set 98	Kv 1.0 - without pre-setting	TWO PIPE	€
CODY.WA4.24.0	24 VDC	83	
CODY.WA4.23.0	230 VAC	83	

CONNECTION SET WITH 2 LOCKSHIELDS G1/2"

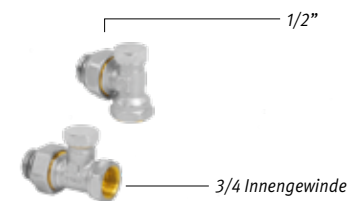

Set 99	€
CODY.LOM.00.0	26



AIR MIXING BOX WITH 0...10V MODULATING MOTOR

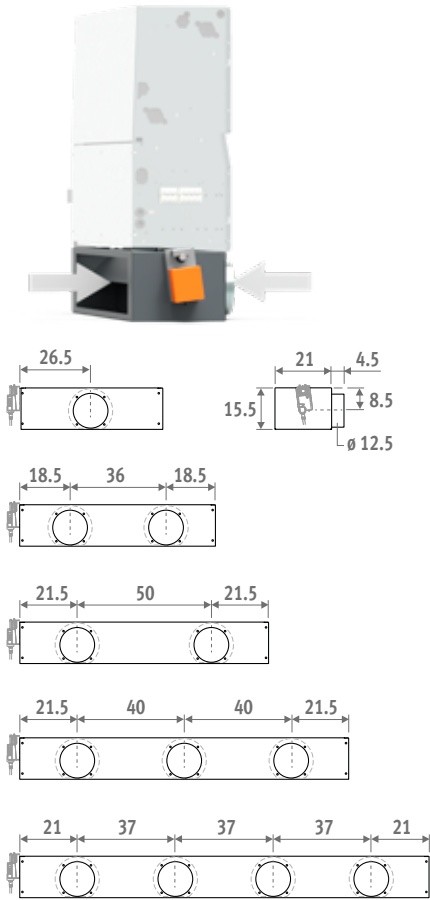

- 230 VAC motorised air in take unit, with modulating adjustable damper (damper position determined by modulating 0 ... 10V signal)
- Connection \varnothing 12.5 cm
- Dark grey painted steel plate - RAL 7024

CODE	L Briza 22	# Connections	€
8763.0301	55	1	711
8763.0302	75	2	756
8763.0303	95	2	793
8763.0304	125	3	832
8763.0305	155	4	923

EXTERNAL GRILLE

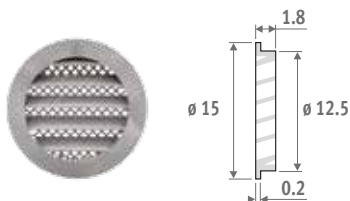

- Natural coloured aluminum external grille \varnothing 12.5 cm
- With fine structured metal anti-vermin grille
- Protection against rain

CODE	€
8776.1750	31

CORNER PIECE 90°

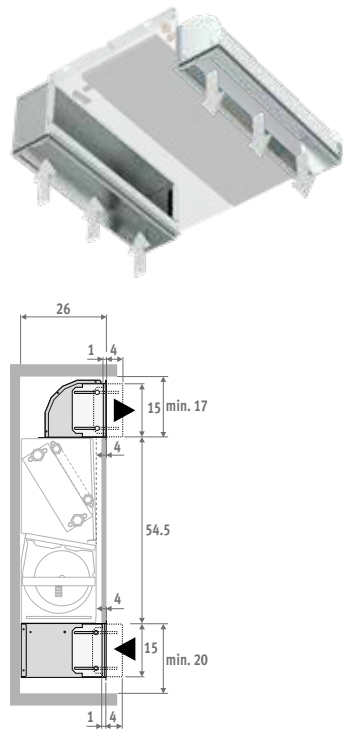

AIR INLET CORNER PIECE 90°

- Height control -1 to + 4 cm
- Galvanised steel plate

CODE	Length Briza 22	€
8787.0101	55	105
8787.0102	75	111
8787.0103	95	120
8787.0104	125	138
8787.0105	155	164

AIR OUTLET CORNER PIECE 90°

- Height control -1 to + 4 cm
- Galvanised steel plate

CODE	Length Briza 22	€
8788.0101	55	98
8788.0102	75	105
8788.0103	95	120
8788.0104	125	127
8788.0105	155	155

GRILLE FOR CORNER PIECE 90°

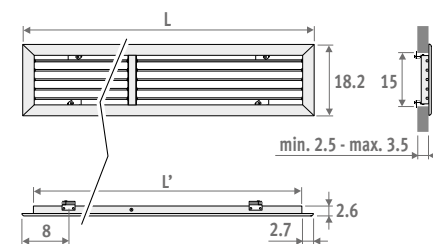

CODE	L Briza 22	Building in-opening	€
8789.201	55	50 x 15	116
8789.202	75	70 x 15	142
8789.203	95	90 x 15	184
8789.204	125	120 x 15	211
8789.205	155	150 x 15	245

PLENUM 180°

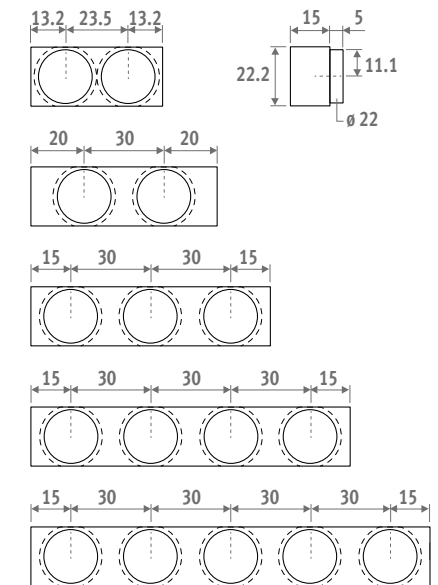
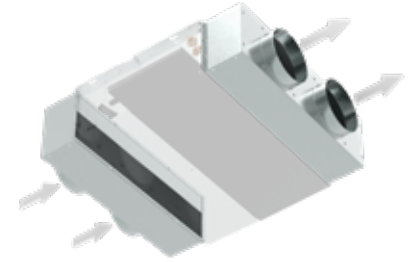

AIR INLET PLENUM 180°

- Connection \varnothing 20 cm
- To fit on the air inlet side
- Galvanised steel plate

CODE	L Briza 22	# Connections	€
8764.0501	55	2	136
8764.0502	75	2	144
8764.0503	95	3	168
8764.0504	125	4	216
8764.0505	155	5	248

AIR EXHAUST PLENUM 180°

- Connection \varnothing 20 cm
- To fit on the air exhaust side
- Acoustically and thermally insulated internal surfaces
- Galvanised steel plate

CODE	L Briza 22	# Connections	€
8764.0601	55	2	208
8764.0602	75	2	217
8764.0603	95	3	257
8764.0604	125	4	310
8764.0605	155	5	343

BRIZA 22 ■ WITH CASING 2-PIPE

STANDARD DELIVERY

- Laquered casing in sendzimir galvanized steel plate with aluminium top grille
- standard colours:
 - traffic white RAL 9016 (133), soft touch lightly structured satin powder coating
 - sandblast grey (001), fine texture metallic powder coating
 - off-black RAL 7021 (145) Soft touch: finely-textured matte look
- Other colours: see colour chart
- back panel to aesthetically seal off the space between the radiator and the wall, prepainted in dark gray RAL 7024
- Energy efficient and maintenance-free EC motor
- Centrifugal fan(s) with twin inlet
- Copper-aluminum 2-pipe hydrophilic coated heat exchanger, G3/4" F.
- Condensate tray with outlet spigot \varnothing 2 cm
- Replaceable polypropylene dust filter (class G2)
- Sturdy casing manufactured from electro-galvanised steel

CONNECTION

Standard connection:

- Hydraulic connections on the left hand side, clamp connector for electric connection 230 VAC on the right hand side.

OTHER CONNECTION:

- Hydraulic right, electric left:
Connection code /70 instead of /20 No surcharge.
ex. BAMW.055 055 22 /BT /70

BAMW

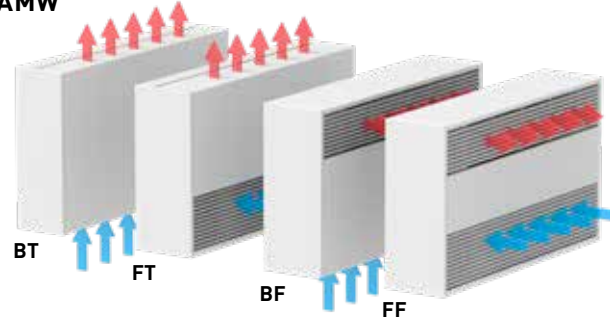

BAMC

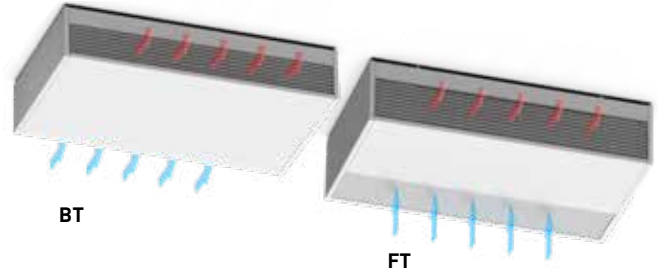

DIMENSIONS			MAX. MEASURED CURRENT	CONTROL VOLTAGE	HEATING ROOM TEMPERATURE 20°C				COOLING TOTAL ROOM TEMPERATURE 27°C		COOLING SENSIBLE ROOM TEMPERATURE 27°C	COOLING (Non-condensing) ROOM TEMPERATURE 27°C	SOUND PRESSURE*	AIR FLOW	POWER CONSUMPTION	PRICE STANDARD COLOURS	2-PIPE
H	L	T			I	U	75/65	55/45	45/35	35/30	7/12	7/12					
cm	cm	cm	A	V	Watts	Watts	Watts	Watts	Watts	Watts	Watts	Watts					
063	090	22	0.5	2	1918	1131	739	461	831	594	338	26	116	3.6	2163	BAMW.063 090 22.XXX /BT /20	
					4	3493	2061	1346	839	1497	1070	605	35	221			8.3
					6	4580	2702	1764	1101	2014	1440	779	43	308			16.1
					8	5541	3269	2134	1331	2467	1764	935	47	391			29.0
					10	6060	3575	2334	1456	2692	1925	1026	51	434			38.2
110	22	0.5	2	2615	1575	1046	665	1279	915	446	21	155	3.5	2471	BAMW.063 110 22.XXX /BT /20		
				4	4678	2819	1872	1190	2209	1579	771	30	284			8.3	
				6	6264	3774	2507	1593	2933	2097	1023	39	396			16.7	
				8	7581	4568	3034	1929	3543	2533	1236	45	503			30.1	
				10	8533	5141	3415	2171	3991	2853	1392	49	591			43.8	
130	22	0.5	2	3430	2014	1310	813	1616	1155	636	22	215	3.8	2694	BAMW.063 130 22.XXX /BT /20		
				4	6051	3552	2310	1435	2804	2005	1104	30	359			9.3	
				6	8190	4808	3127	1942	3767	2694	1483	37	491			19.1	
				8	9959	5846	3802	2361	4557	3258	1794	43	614			33.5	
				10	11098	6515	4237	2631	5060	3618	1992	47	703			47.8	
160	22	1.0	2	4722	2826	1867	1180	1930	1380	694	28	290	7.0	4040	BAMW.063 160 22.XXX /BT /20		
				4	8160	4884	3226	2038	3345	2392	1203	36	534			16.6	
				6	10677	6390	4221	2667	4439	3174	1597	43	730			33.9	
				8	13036	7802	5153	3256	5524	3949	1987	49	931			59.4	
				10	14479	8665	5724	3617	6224	4450	2239	53	1065			83.5	
190	22	1.0	2	4691	2826	1877	1193	2112	1510	737	25	341	7.0	4402	BAMW.063 190 22.XXX /BT /20		
				4	8383	5051	3355	2133	3823	2733	1334	34	614			16.9	
				6	11605	6992	4644	2952	5322	3805	1857	41	860			34.8	
				8	14491	8731	5799	3686	6670	4769	2327	47	1088			61.8	
				10	16462	9919	6587	4188	7595	5430	2650	51	1247			89.2	

Output measured in accordance with EN 1397

* Noise measurement according to ISO 3741:2010, 2 m from the device and with an assumed room attenuation of 8 dB(A) / room volume 100 m³ / reverberation time 0.5 sec.

BAMW (Wall mounted model)
BAMC (Ceiling mounted model)

BT (Bottom Top)
FT (Front Top)
BF (Bottom Front)
FF (Front Front)

enter colour code

WITH CASING 4-PIPE - BRIZA 22

STANDARD DELIVERY

- Laquered casing in sendzimir galvanized steel plate with aluminium top grille
- standard colours:
 - raffic white RAL 9016 (133), soft touch lightly structured satin powder coating
 - Sandblast grey (001), Ffine texture metallic powder coating
 - off-black RAL 7021 (145) Soft touch: finely-textured matte look
- Other colours: see colour chart
- back panel to aesthetically seal off the space between the radiator and the wall, prepainted in dark gray RAL 7024
- Eenergy efficient and maintenance-free EC motor
- Centrifugal fan(s) with twin inlet
- Copper-aluminum 2-pipe hydrophilic coated heat exchanger, G3/4" F.
- Second heat exchanger, G1/2" F
- Condensate tray with outlet spigot ø 2 cm
- Replaceable polypropylene dust filter (class G2)
- Sturdy casing manufactured from electro-galvanised steel

CONNECTION

Standard connection:

- Hydraulic connections on the left hand side, clamp connector for electric connection 230 VAC on the right hand side.

OTHER CONNECTION:

- Hydraulic right, electric left:
Connection code /70 instead of /20 No surcharge.
ex. BAMW.055 055 22 /BT /70

BAMW

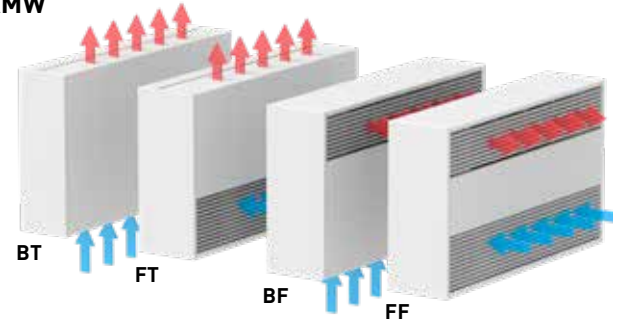

BAMC

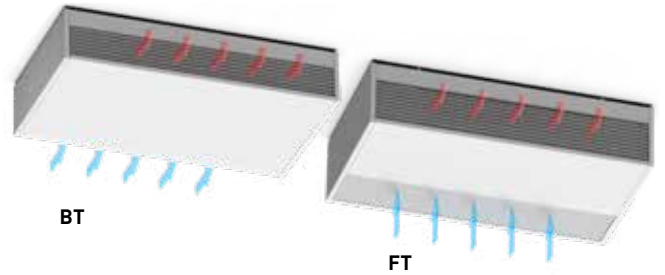

DIMENSIONS			MAX. MEASURED CURRENT	CONTROL VOLTAGE	HEATING ROOM TEMPERATURE 20°C				COOLING TOTAL ROOM TEMPERATURE 27°C		COOLING SENSIBLE ROOM TEMPERATURE 27°C	COOLING (Non-condensing) ROOM TEMPERATURE 27°C	SOUND PRESSURE* dB(A)	AIR FLOW m³/h	POWER CONSUMPTION Watts	PRICE STANDARD COLOURS €	4-PIPE
H cm	L cm	T cm			I A	U V	75/65 Watts	55/45 Watts	45/35 Watts	35/30 Watts	7/12 Watts	7/12 Watts					
063	090	22	0.5	2	1326	738	460	273	831	594	338	26	116	3.6	2384	BAMW.63 090 22.XXX /BT /4 /20	
					4	1724	960	598	355	1497	1070	605	35	221			8.3
					6	2114	1177	734	435	2014	1440	779	43	308			16.1
					8	2386	1329	828	491	2467	1764	935	47	391			29.0
					10	2505	1395	869	515	2692	1925	1026	51	434			38.2
110	22	0.5	2	1490	830	518	307	1279	915	446	21	155	3.5	2709	BAMW.063 110 22.XXX /BT /4 /20		
				4	2366	1318	822	487	2209	1579	771	30	284			8.3	
				6	2955	1646	1026	608	2933	2097	1023	39	396			16.7	
				8	3382	1885	1175	696	3543	2533	1236	45	503			30.1	
				10	3652	2035	1269	752	3991	2853	1392	49	591			43.8	
130	22	0.5	2	2110	1170	726	429	1616	1155	636	22	215	3.8	2991	BAMW.063 130 22.XXX /BT /4 /20		
				4	3112	1725	1071	632	2804	2005	1104	30	359			9.3	
				6	3825	2120	1316	777	3767	2694	1483	37	491			19.1	
				8	4336	2404	1492	881	4557	3258	1794	43	614			33.5	
				10	4627	2565	1593	940	5060	3618	1992	47	703			47.8	
160	22	1.0	2	3587	2027	1278	767	1930	1380	694	28	290	7.0	4379	BAMW.063 160 22.XXX /BT /4 /20		
				4	4951	2798	1764	1059	3345	2392	1203	36	534			16.6	
				6	5898	3333	2102	1262	4439	3174	1597	43	730			33.9	
				8	6733	3805	2399	1440	5524	3949	1987	49	931			59.4	
				10	7211	4075	2570	1542	6224	4450	2239	53	1065			83.5	
190	22	1.0	2	3320	1891	1200	725	2112	1510	737	25	341	7.0	4756	BAMW.063 190 22.XXX /BT /4 /20		
				4	5199	2960	1878	1135	3823	2733	1334	34	614			16.9	
				6	6713	3822	2425	1466	5322	3805	1857	41	860			34.8	
				8	7960	4533	2876	1738	6670	4769	2327	47	1088			61.8	
				10	8748	4981	3160	1910	7595	5430	2650	51	1247			89.2	

Output measured in accordance with EN 1397

* Noise measurement according to ISO 3741:2010, 2 m from the device and with an assumed room attenuation of 8 dB(A) / room volume 100 m³ / reverberation time 0.5 sec.

BAMW (Wall mounted model)
BAMC (Ceiling mounted model)

enter colour code

BT (Bottom Top)
FT (Front Top)
BF (Bottom Front)
FF (Front Front)

BRIZA 22 ■ 2-PIPE

STANDARD DELIVERY

- Energy efficient and maintenance-free EC motor
- Centrifugal fan(s) with twin inlet
- Copper-aluminum 2-pipe hydrophilic coated heat exchanger, G3/4" F.
- Condensate tray with outlet spigot ø 2 cm
- Replaceable polypropylene dust filter (class G2)
- Sturdy casing manufactured from electro-galvanised steel

CONNECTION

Standard connection:

- Hydraulic connections on the left hand side, clamp connector for electric connection 230 VAC on the right hand side.

OTHER CONNECTION

- Hydraulic right, electric left:
Connection code /70 instead of /20
No surcharge.
ex.BABW.055 055 22 /BT /70

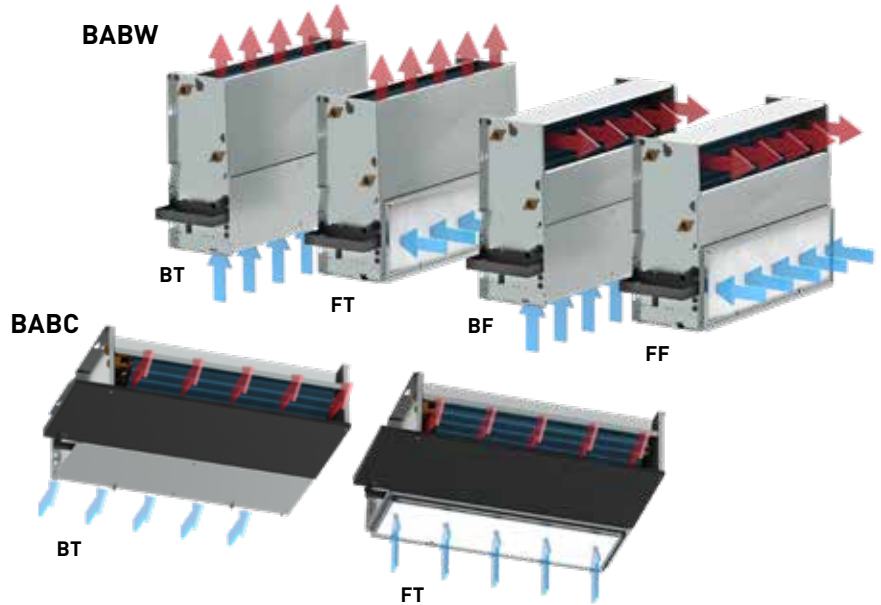

DIMENSIONS			MAX. MEASURED CURRENT	CONTROL VOLTAGE	HEATING ROOM TEMPERATURE 20°C				COOLING TOTAL ROOM TEMPERATURE 27°C		COOLING SENSIBLE ROOM TEMPERATURE 27°C	SOUND PRESSURE* dB(A)	AIR FLOW m³/h	POWER CONSUMPTION Watts	PRICE €	2-PIPE	
H cm	L cm	T cm			I A	U V	75/65 Watts	55/45 Watts	45/35 Watts	35/30 Watts	7/12 Watts						7/12 Watts
055	055	22	0.5	2	2213	1305	852	532	939	677	390	26	134	3.7	1654	BABW.055 055 22 /BT /20	
					4	3924	2315	1512	943	1685	1214	674	35	254			8.7
					6	5122	3022	1973	1231	2256	1626	866	43	355			17.2
					8	6255	3690	2409	1503	2749	1981	1061	47	450			31.1
					10	6909	4076	2661	1660	2991	2155	1185	51	500			41.1
075	22	0.5	2	3010	1814	1204	766	1445	1041	508	21	178	3.7	1927	BABW.055 075 22 /BT /20		
				4	5307	3197	2124	1350	2475	1784	870	30	327			8.8	
				6	7026	4233	2811	1787	3258	2348	1146	39	456			17.7	
				8	8409	5067	3365	2139	3901	2811	1372	45	579			31.9	
				10	9370	5646	3749	2384	4358	3141	1533	49	681			46.4	
095	22	0.5	2	4049	2377	1546	960	1882	1356	747	22	247	3.9	2105	BABW.055 095 22 /BT /20		
				4	6960	4086	2657	1650	3189	2298	1266	30	413			9.9	
				6	9281	5448	3543	2200	4221	3042	1675	37	565			20.6	
				8	11143	6541	4254	2642	5040	3632	2000	43	707			35.9	
				10	12305	7223	4698	2918	5543	3995	2200	47	809			51.2	
125	22	1.0	2	5366	3211	2121	1340	2172	1565	787	28	334	7.2	3255	BABW.055 125 22 /BT /20		
				4	9224	5520	3647	2304	3771	2718	1367	36	614			17.5	
				6	11998	7181	4743	2997	4999	3603	1812	43	840			35.7	
				8	14548	8706	5751	3634	6209	4475	2251	49	1072			62.8	
				10	16076	9621	6355	4016	6985	5034	2533	53	1226			88.5	
155	22	1.0	2	4889	2946	1956	1244	2420	1393	680	25	392	7.2	3598	BABW.055 155 22 /BT /20		
				4	9374	5648	3751	2385	4358	2978	1453	34	706			17.8	
				6	13215	7962	5288	3362	6048	4325	2110	41	990			37.1	
				8	16591	9996	6639	4221	7562	5499	2683	47	1252			65.8	
				10	18859	11363	7547	4797	8596	6282	3065	51	1436			95.0	

Output measured in accordance with EN 1397

* Noise measurement according to ISO 3741:2010, 2 m from the device and with an assumed room attenuation of 8 dB(A) / room volume 100 m³ / reverberation time 0.5 sec.

BABW (Installation in a wall recess)
BABC (Built-in ceiling)

BT (Bottom Top)
FT (Front Top)
BF (Bottom Front)
FF (Front Front)

BUILT-IN 4-PIPE - BRIZA 22

STANDARD DELIVERY

- Energy efficient and maintenance-free EC motor
- Centrifugal fan(s) with twin inlet
- For more information
- Second heat exchanger, G1/2" F
- Condensate tray with outlet spigot \varnothing 2 cm
- Replaceable polypropylene dust filter (class G2)
- Sturdy casing manufactured from electro-galvanised steel

CONNECTION

Standard connection:

- Hydraulic connections on the left hand side, clamp connector for electric connection 230 VAC on the right hand side.

OTHER CONNECTION:

- Hydraulic right, electric left:
Connection code /70 instead of /20
No surcharge.
ex. BABW.055 055 22 /BT /4 /70

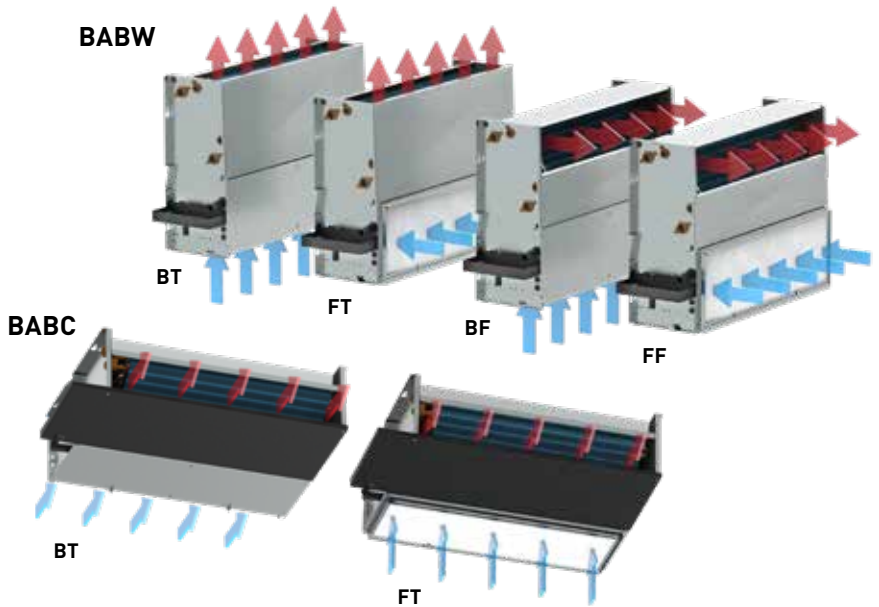

DIMENSIONS			MAX. MEASURED CURRENT	CONTROL VOLTAGE	HEATING ROOM TEMPERATURE 20°C				COOLING TOTAL ROOM TEMPERATURE 27°C		COOLING SENSIBLE ROOM TEMPERATURE 27°C	COOLING (Non-condensing) ROOM TEMPERATURE 27°C	SOUND PRESSURE*	AIR FLOW	POWER CONSUMPTION	PRICE	4-PIPE
H	L	T			I	U	75/65	55/45	45/35	35/30	7/12	7/12					
cm	cm		A	V	Watts	Watts	Watts	Watts	Watts	Watts	Watts						
055	055	22	0.5	2	1367	761	475	281	939	677	390	26	134	3.7	1875	BABW.055 055 22 /BT /4 /20	
					4	1881	1047	653	387	1685	1214	674	35	254			8.7
					6	2279	1269	791	469	2256	1626	866	43	355			17.2
					8	2550	1420	885	524	2749	1981	1061	47	450			31.1
					10	2726	1518	946	561	2991	2155	1185	51	500			41.1
075	22	0.5	2	1908	1063	663	393	1445	1041	508	21	178	3.7	2165	BABW.055 075 22 /BT /4 /20		
				4	2653	1478	922	546	2475	1784	870	30	327			8.8	
				6	3174	1768	1102	653	3258	2348	1146	39	456			17.7	
				8	3556	1981	1235	732	3901	2811	1372	45	579			31.9	
				10	3790	2112	1316	780	4358	3141	1533	49	681			46.4	
095	22	0.5	2	2484	1377	855	505	1882	1356	747	22	247	3.9	2402	BABW.055 095 22 /BT /4 /20		
				4	3404	1887	1172	691	3189	2298	1266	30	413			9.9	
				6	4077	2260	1403	828	4221	3042	1675	37	565			20.6	
				8	4558	2527	1569	926	5040	3632	2000	43	707			35.9	
				10	4817	2670	1658	978	5543	3995	2200	47	809			51.2	
125	22	1.0	2	3848	2174	1371	823	2172	1565	787	28	334	7.2	3595	BABW.055 125 22 /BT /4 /20		
				4	5357	3027	1909	1146	3771	2718	1367	36	614			17.5	
				6	6373	3601	2271	1363	4999	3603	1812	43	840			35.7	
				8	7233	4087	2577	1547	6209	4475	2251	49	1072			62.8	
				10	7703	4353	2745	1648	6985	5034	2533	53	1226			88.5	
155	22	1.0	2	3691	2102	1334	806	2420	1393	680	25	392	7.2	3952	BABW.055 155 22 /BT /4 /20		
				4	5789	3297	2092	1264	4358	2978	1453	34	706			17.8	
				6	7443	4238	2689	1625	6048	4325	2110	41	990			37.1	
				8	8770	4994	3168	1915	7562	5499	2683	47	1252			65.8	
				10	9585	5457	3463	2093	8596	6282	3065	51	1436			95.0	

Output measured in accordance with EN 1397

* Noise measurement according to ISO 3741:2010, 2 m from the device and with an assumed room attenuation of 8 dB(A) / room volume 100 m³ / reverberation time 0.5 sec.

BABW ((Installation in a wall recess)

BABC (Built-in ceiling)

BT (Bottom Top)

FT (Front Top)

BF (Bottom Front)

FF (Front Front)

versatile