

versatile

Sizing, installation, dimensions and weights GOLD PX & GOLD CX

The charts and tables in this documentation are intended for use as a general survey.

Exact sizing can be carried out in the AHU Design air handling unit selection program.

Contents

GOLD PX

Size 004.....	74
Size 005.....	78
Size 007.....	82
Size 008.....	86
Size 011.....	90
Size 012.....	93
Size 014/020	96
Size 025/030	100
Size 035/040	104

GOLD CX

Size 035/040	107
Size 050/060	110
Size 070/080	113
Size 100.....	116
Size 120.....	118

Electrical data

GOLD PX size 014-040.....	120
GOLD CX size 035-120.....	121

Sizing, installation, dimensions and weights

GOLD PX, counterflow heat exchanger, size 004

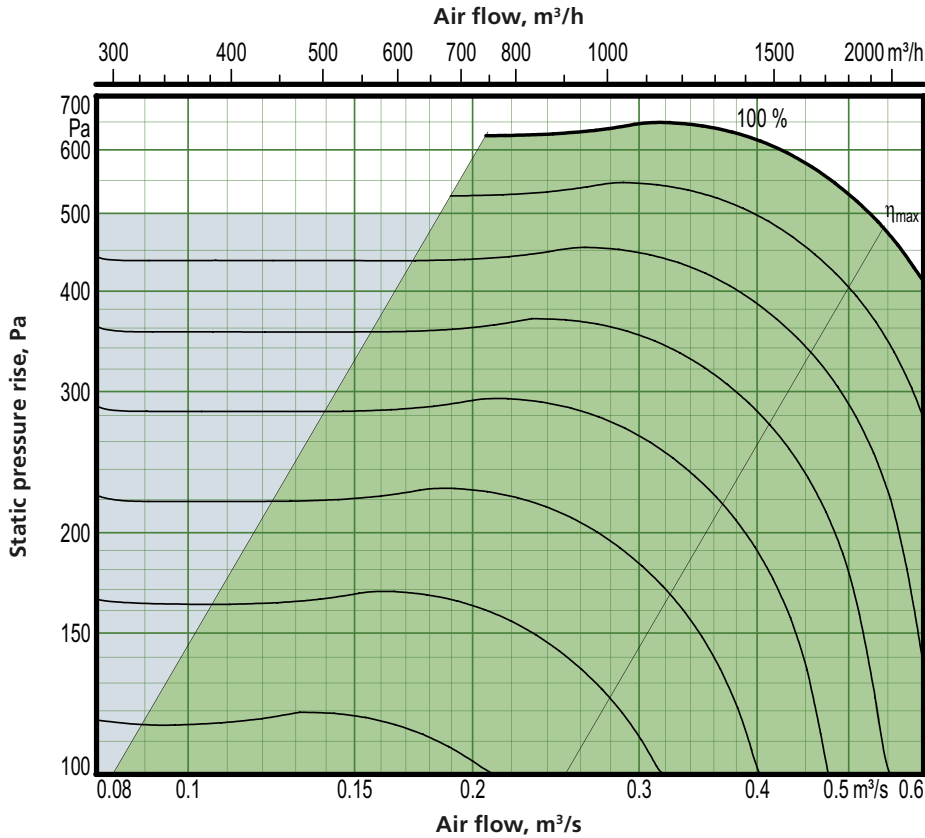

Motor shaft power: 1.15 kW (0.41 kW)

- Recommended working range for sizing.
- If pressure regulation is used, the air flow can be regulated to zero.
- However this presupposes a certain static pressure drop in the ducting (approx. 50 Pa).

Min. and max. airflows

The flows specified refer to those that can be preset in the hand-held terminal. The practical flow limits are determined by the external pressure drop.

Size	Min. airflow (on airflow regulation)		Max. airflow	
	m³/h	m³/s	m³/h	m³/s
004	288	0.08	1620	0.45

Exact sizing can be carried out in the AHU Design air handling unit selection program

Sizing, installation, dimensions and weights

GOLD PX, counterflow heat exchanger, size 004, common casing

Delivery and transport within the site

The GOLD PX 004 is produced in one single variant. All of its components are arranged at their given physical locations inside the air handling unit.

The electrical cabinet and the drain pipe on the front of the air handling unit can be removed, if required, for transporting the unit within the building site.

The air handling unit is supplied on a wooden pallet.

The set of support legs, for mounting the base beams, is available as an accessory.

Duct connection options

A: Specify right-hand or left-hand version when ordering.

B: Specify whether the unit shall have an air intake from above for outdoor air and/or extract air when placing orders (does not apply to outdoor units).

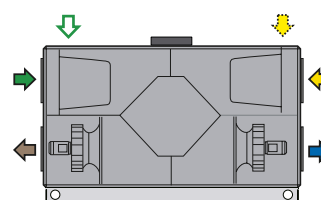

Right-hand version

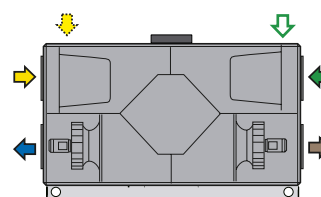

Left-hand version

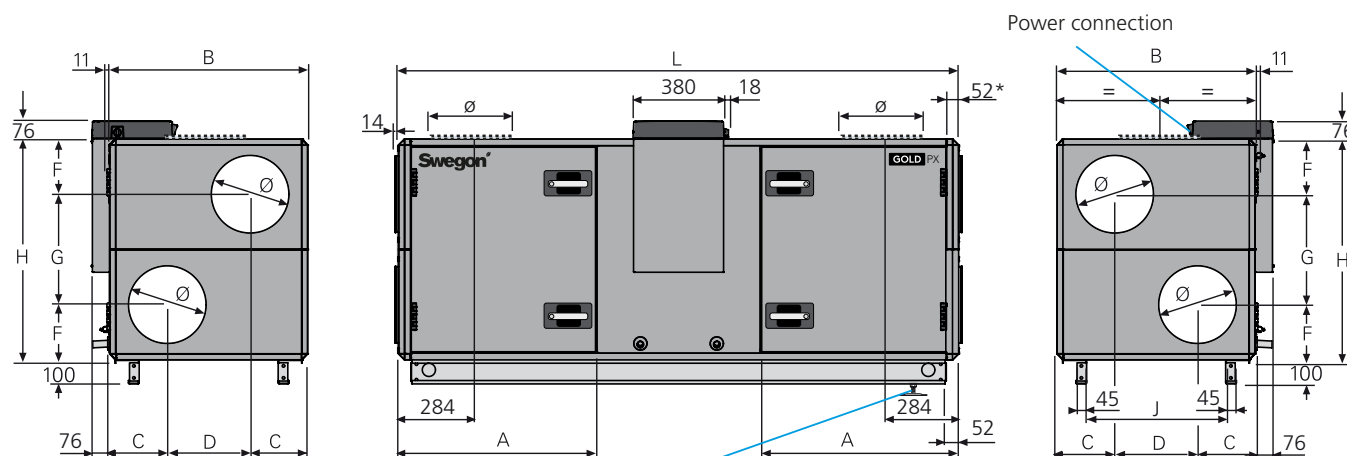
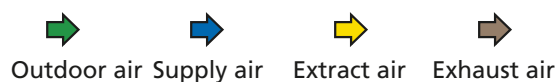

If a water trap (accessory) is fitted, the air handling unit must be raised at least 50 mm to provide space for the water trap. Support feet (accessories) can be used for this purpose.

* The air handling unit is supplied without end connection panel if a duct accessory housed in an insulated casing will be connected. The AHU can also be supplied with full face end connection panel (accessory).

Size	A	B	C	D	F	G	H	J	L	Ø	Weight, kg
004	822	825	240	345	230	460	920	579	2333	315	349-387

Clear Space for Inspection

A clear space of 900 mm must be provided in front of the unit and at least 200 mm must be provided above the junction hood.

Power connection

1-phase, 3-wire, 230 V -10/+15%, 50 Hz, 10 A or 3-phase, 5-wire, 400 V -10/+15%, 50 Hz, 10 A

Rated data per fan

Motor shaft power: 1.15 kW (0.41 kW)*
motor control system, 1 x 230 V, 50 Hz

*The motor control system limits the power of the take-off to the value specified.

Sizing, installation, dimensions and weights

GOLD PX, counterflow heat exchanger, size 004, split version

Delivery and transport within the site

The GOLD PX 004 can be supplied as one single unit, or in a number of different combinations of unit sections from the factory, see the section: Description of the Air Handling Unit/ Delivery Configuration RX/PX/CX, sizes 004-080.

The unit sections are jointed together/split by means of bolts. The electrical and control cables between the unit sections have quick-fit connectors.

The air handling unit/unit sections is/are delivered on wooden beams.

The electrical cabinet and the drain pipe on the front of the air handling unit can be removed, if required, for transporting the unit within the building site.

Duct connection options

A: Specify right-hand or left-hand version when ordering.

B: Specify whether the unit shall have an air intake from above for outdoor air and/or extract air when placing orders (does not apply to outdoor units).

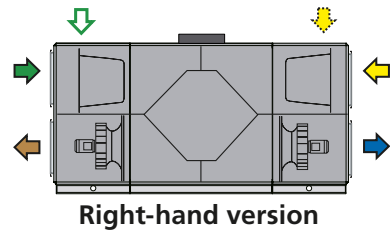

Right-hand version

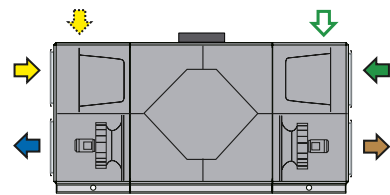

Left-hand version

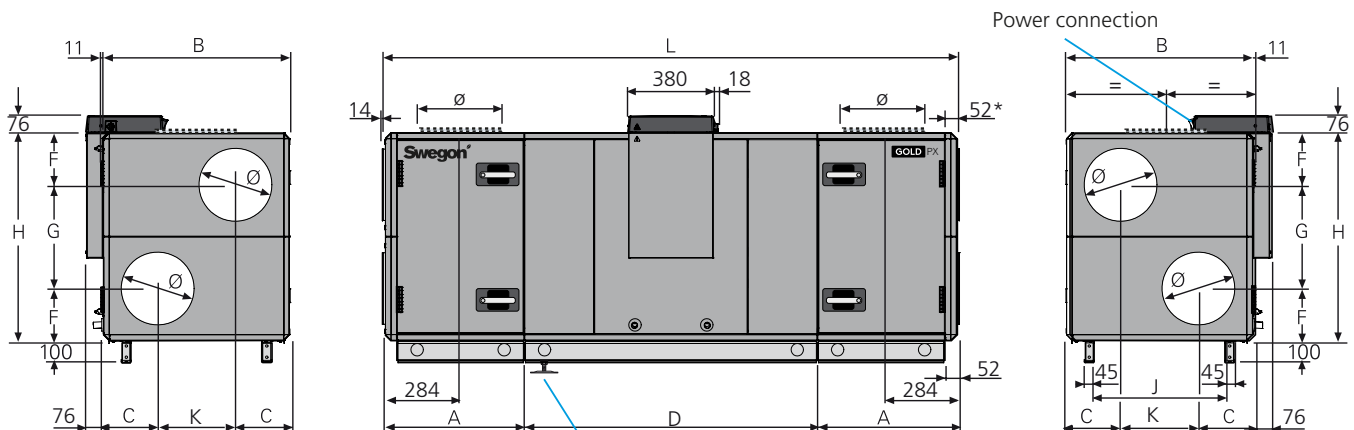

If a water trap (accessory) is fitted, the air handling unit must be raised at least 50 mm to provide space for the water trap. Support feet (accessories) can be used for this purpose.

* The air handling unit is supplied without end connection panel if a duct accessory housed in an insulated casing will be connected. The AHU can also be supplied with full face end connection panel (accessory).

Size	A	B	C	D	F	G	H	J	K	L	Ø	Weight, kg
004	617	825	240	1300	230	460	920	579	345	2534	315	438-490

Division into sections for transport

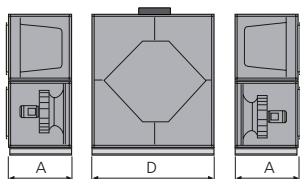

The unit can be divided into three sections at the building site.

Dimensions: See A and D in the table above.

Weight: A = 88-112 kg, D = 262-266 kg.

Power connection

1-phase, 3-wire, 230 V -10/+15%, 50 Hz, 10 A or 3-phase, 5-wire, 400 V -10/+15%, 50 Hz, 10 A

Rated data per fan

Motor shaft power 1.15 kW (0.41 kW)*,

Motor control system: 1 x 230 V, 50 Hz

*The motor control system limits the output power to the value specified.

Clear space for inspection

A clear space of 900 mm should be provided in front of the unit and at least 200 mm should be provided above the junction hood.

Sizing, installation, dimensions and weights

GOLD PX Top, counterflow heat exchanger, size 004

Delivery and transport within the site

GOLD PX Top 004 can be supplied as one single unit or in an optional division of sections. Extra air handling unit sections cannot be ordered due to the deviating height measurement. Filter/fan sections for height adapted PX (side fed) and PX Top can be combined, see the section: Description of the Air Handling Unit.

The unit sections are jointed together/split by means of bolts. The electrical and control cables between the unit sections have quick-fit connectors.

The air handling unit/unit sections is/are delivered on wooden beams.

The electrical cabinet and the drain pipe on the front of the air handling unit can be removed, if required, for transporting the unit within the building site.

Duct connection options

A: All the duct connections are arranged from the top of the air handling unit (the unit must not be installed outdoors).

B: Specify right-hand or left-hand version when ordering.

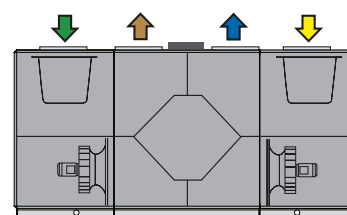

Right-hand version

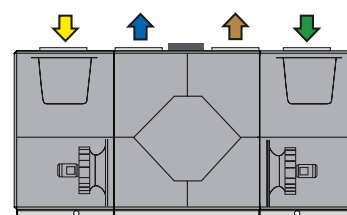

Left-hand version

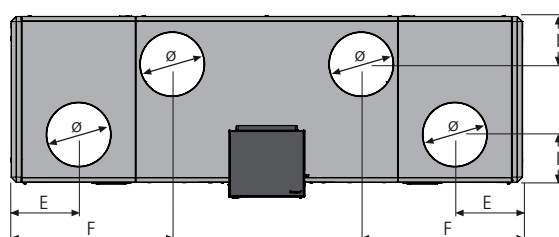
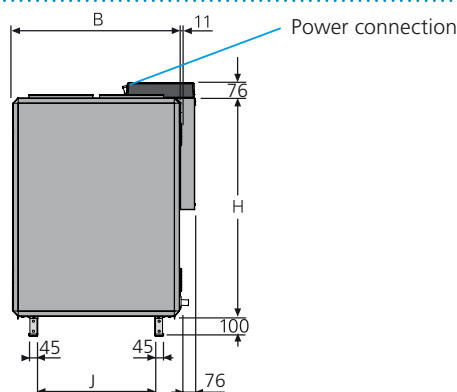
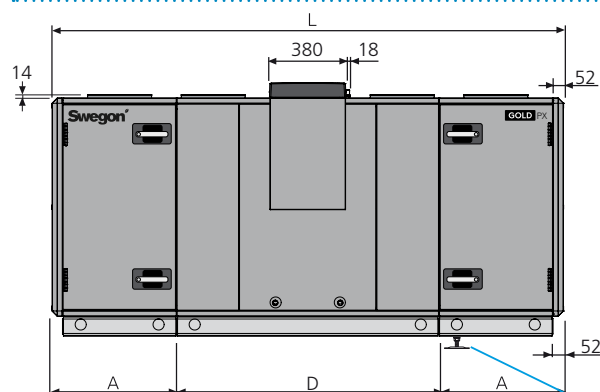

If a water trap (accessory) is fitted, the air handling unit must be raised at least 50 mm to provide space for the water trap. Support feet (accessories) can be used for this purpose.

Size	A	B	D	E	F	H	I	J	L	Ø	Weight, kg
004	617	825	1300	334	798	1085	238	579	2534	315	480-484

Division into sections for transport

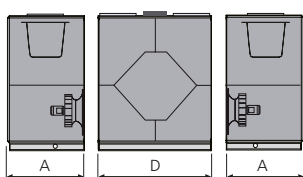

The unit can be divided into three sections at the building site.

Dimensions: See A and D in the table above.

Weight: A = 109 kg, D = 262-266 kg.

Electrical connection

1-phase, 3-wire, 230 V -10/+15%, 50 Hz, 10 A or 3-phase, 5-wire, 400 V -10/+15%, 50 Hz, 10 A

Rated data per fan

Motor shaft power 1.15 kW (0.41 kW)*, motor control system: 1 x 230 V, 50 Hz

*The motor control system limits the output power to the value specified.

Clear space for inspection

A clear space of 900 mm should be provided in front of the unit and at least 200 mm should be provided above the junction hood.

Sizing, installation, dimensions and weights

GOLD PX, counterflow heat exchanger, size 005

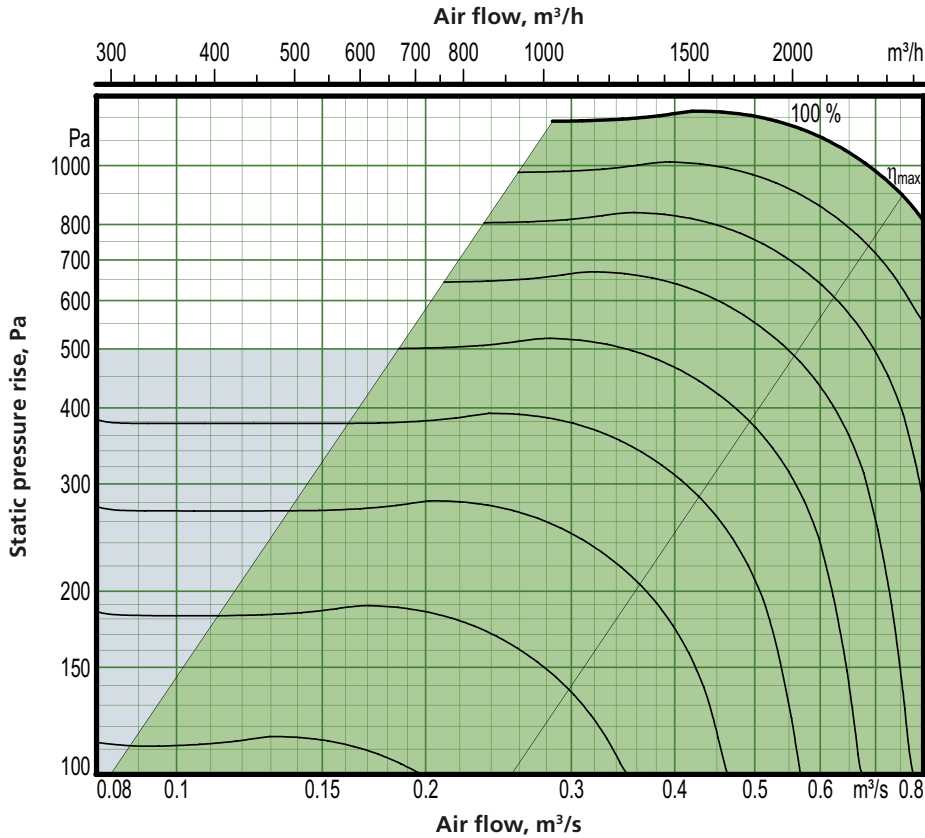

Motor shaft power: 1.15 kW (capacity variant 2)

- Recommended working range for sizing.
- If pressure regulation is used, the air flow can be regulated to zero.
- However this presupposes a certain static pressure drop in the ducting (approx. 50 Pa).

Min. and max. air flows

The flows specified refer to those that can be preset in the hand-held terminal. The practical flow limits are determined by the external pressure drop.

Size	Min. airflow (on airflow regulation)		Max. airflow	
	m ³ /h	m ³ /s	m ³ /h	m ³ /s
005	288	0.08	2340	0.65

Exact sizing can be carried out in the AHU Design air handling unit selection program

Sizing, installation, dimensions and weights

GOLD PX, counterflow heat exchanger, size 005, common casing

Delivery and transport within the site

The GOLD PX 005 is produced in one single variant, in which all the components are arranged at their given physical locations inside the air handling unit.

The electrical cabinet and the drain pipe on the front of the air handling unit can be removed, if required, for transporting the unit within the building site.

The air handling unit is supplied on a wooden pallet.

The set of support legs, for mounting the base beams, is available as an accessory.

Duct connection options

A: Specify right-hand or left-hand version when ordering.

B: Specify whether the unit shall have an air intake from above for outdoor air and/or extract air when placing orders (does not apply to outdoor units).

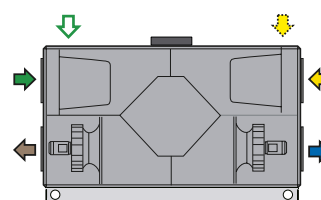

Right-hand version

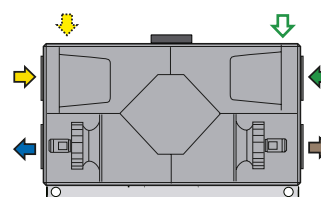

Left-hand version

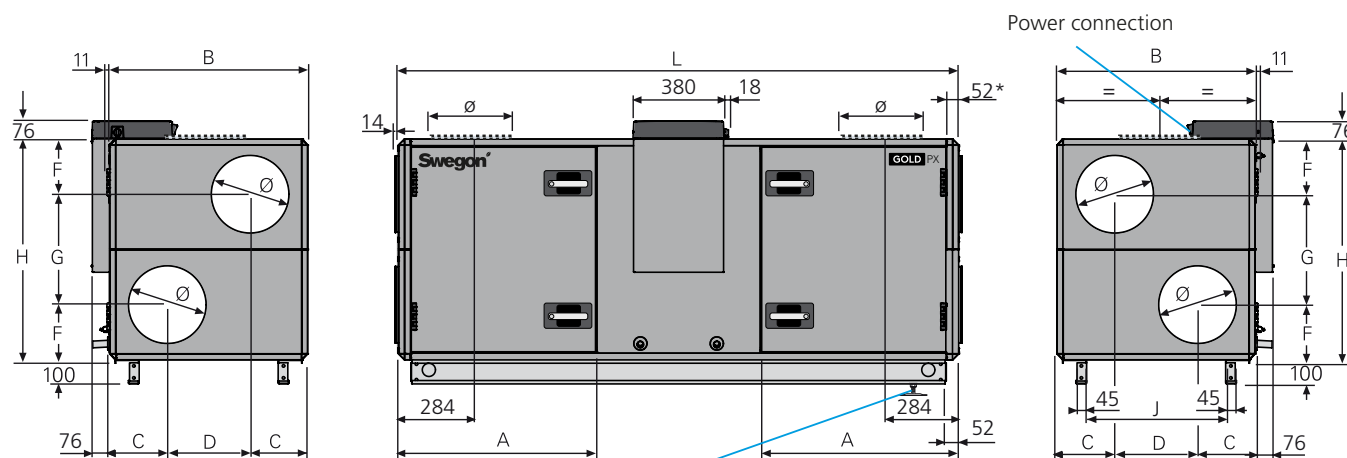
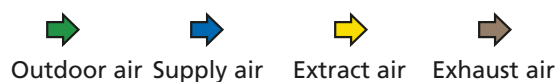

If a water trap (accessory) is fitted, the air handling unit must be raised at least 50 mm to provide space for the water trap. Support feet (accessories) can be used for this purpose.

* The air handling unit is supplied without end connection panel if a duct accessory housed in an insulated casing will be connected. The AHU can also be supplied with full face end connection panel (accessory).

Size	A	B	C	D	F	G	H	J	L	Ø	Weight, kg
005	822	825	240	345	230	460	920	579	2333	315	349-387

Clear Space for Inspection

A clear space of 900 mm must be provided in front of the unit and at least 200 mm must be provided above the junction hood.

Power connection

1-phase, 3-wire, 230 V -10/+15%, 50 Hz, 10 A (capacity variant 1) alt. 16 A (capacity variant 2) or 3-phase, 5-wire, 400 V -10/+15%, 50 Hz, 10 A

Rated data per fan

Motor shaft power: 1.15 kW (0.8 kW* or 1.15 kW), motor control system: 1 x 230 V, 50 Hz

*The motor control system limits the output power to the value specified.

Sizing, installation, dimensions and weights

GOLD PX, counterflow heat exchanger, size 005, split version

Delivery and transport within the site

The GOLD PX 005 can be supplied as one single unit, or in a number of different combinations of unit sections from the factory, see the section: Description of the Air Handling Unit/ Delivery Configuration RX/PX/CX, sizes 004-080.

The unit sections are jointed together/split by means of bolts. The electrical and control cables between the unit sections have quick-fit connectors.

The air handling unit/unit sections is/are delivered on wooden beams.

The electrical cabinet and the drain pipe on the front of the air handling unit can be removed, if required, for transporting the unit within the building site.

Duct connection options

A: Specify right-hand or left-hand version when ordering.

B: Specify whether the unit shall have an air intake from above for outdoor air and/or extract air when placing orders (does not apply to outdoor units).

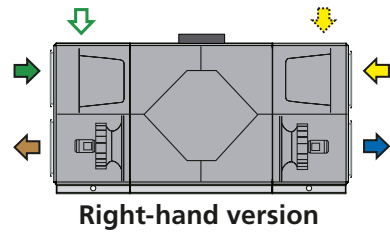

Right-hand version

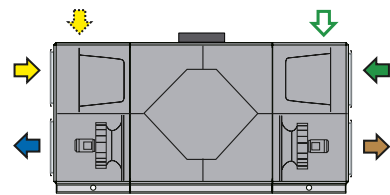

Left-hand version

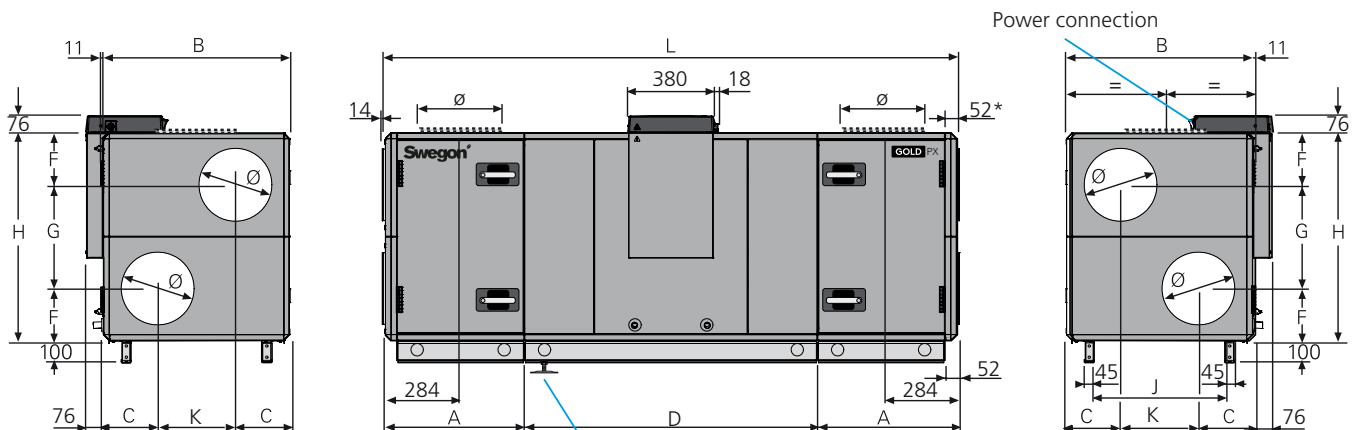

If a water trap (accessory) is fitted, the air handling unit must be raised at least 50 mm to provide space for the water trap. Support feet (accessories) can be used for this purpose.

* The air handling unit is supplied without end connection panel if a duct accessory housed in an insulated casing will be connected. The AHU can also be supplied with full face end connection panel (accessory).

Size	A	B	C	D	F	G	H	J	K	L	Ø	Weight, kg
005	617	825	240	1300	230	460	920	579	345	2534	315	438-490

Division into sections for transport

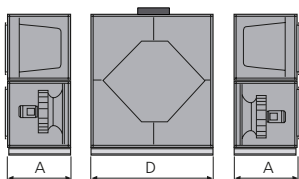

The unit can be divided into three sections at the building site.

Dimensions: See A and D in the table above.

Weight: A = 88-112 kg, D = 262-266 kg.

Power connection

1-phase, 3-wire, 230 V -10/+15%, 50 Hz, 10 A (capacity variant 1) or 16 A (capacity variant 2) or 3-phase, 5-wire, 400 V -10/+15%, 50 Hz, 10 A

Rated data per fan

Motor shaft power: 1.15 kW (0.8 kW* or 1.15 kW), motor control system: 1 x 230 V, 50 Hz

*The motor control system limits the output power to the value specified.

Clear space for inspection

A clear space of 900 mm should be provided in front of the unit and at least 200 mm should be provided above the junction hood.

Sizing, installation, dimensions and weights

GOLD PX Top, counterflow heat exchanger, size 005

Delivery and transport within the site

GOLD PX Top 005 can be supplied as one single unit or in an optional division of sections. Extra air handling unit sections cannot be ordered due to the deviating height measurement. Filter/fan sections for height adapted PX (side fed) and PX Top can be combined, see the section: Description of the Air Handling Unit.

The unit sections are jointed together/split by means of bolts. The electrical and control cables between the unit sections have quick-fit connectors.

The air handling unit/unit sections is/are delivered on wooden beams.

The electrical cabinet and the drain pipe on the front of the air handling unit can be removed, if required, for transporting the unit within the building site.

Duct connection options

A: All the duct connections are arranged from the top of the air handling unit (the unit must not be installed outdoors).

B: Specify right-hand or left-hand version when ordering.

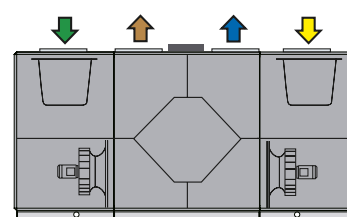

Right-hand version

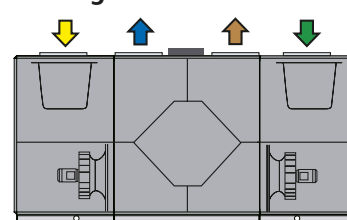

Left-hand version

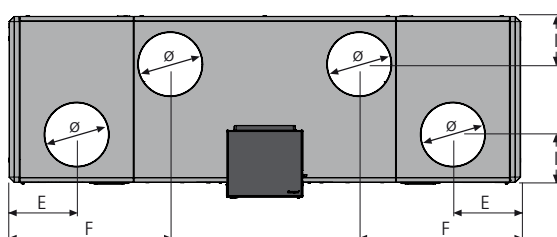
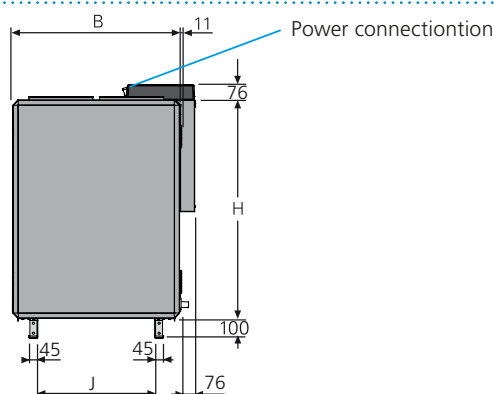
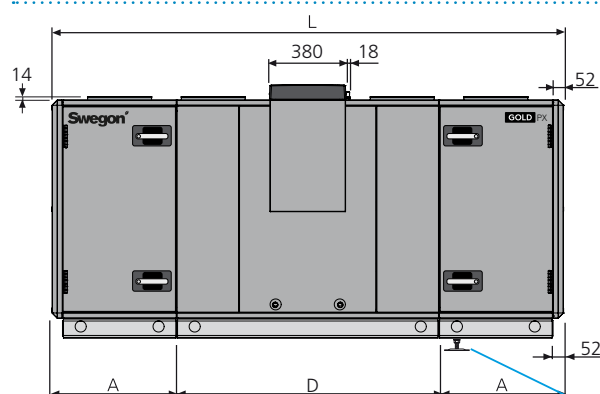
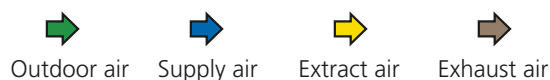

If a water trap (accessory) is fitted, the air handling unit must be raised at least 50 mm to provide space for the water trap. Support feet (accessories) can be used for this purpose.

Size	A	B	D	E	F	H	I	J	L	Ø	Weight, kg
005	617	825	1300	334	798	1085	238	579	2534	315	480-492

Division into sections for transport

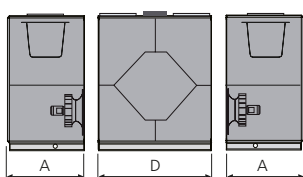

The unit can be divided into three sections at the building site.

Dimensions: See A and D in the table above.

Weight: A = 109-113 kg, D = 262-266 kg.

Clear space for inspection

A clear space of 900 mm should be provided in front of the unit and at least 200 mm should be provided above the junction hood.

Electrical connection

1-phase, 3-wire, 230 V -10/+15%, 50 Hz, 10 A (capacity variant 1) or 16 A (capacity variant 2) or 3-phase, 5-wire, 400 V -10/+15%, 50 Hz, 10 A

Rated data per fan

Motor shaft power: 1.15 kW (0.8 kW* or 1.15 kW), motor control system: 1 x 230 V, 50 Hz

*The motor control system limits the output power to the value specified.

Sizing, installation, dimensions and weights

GOLD PX, counterflow heat exchanger, size 007

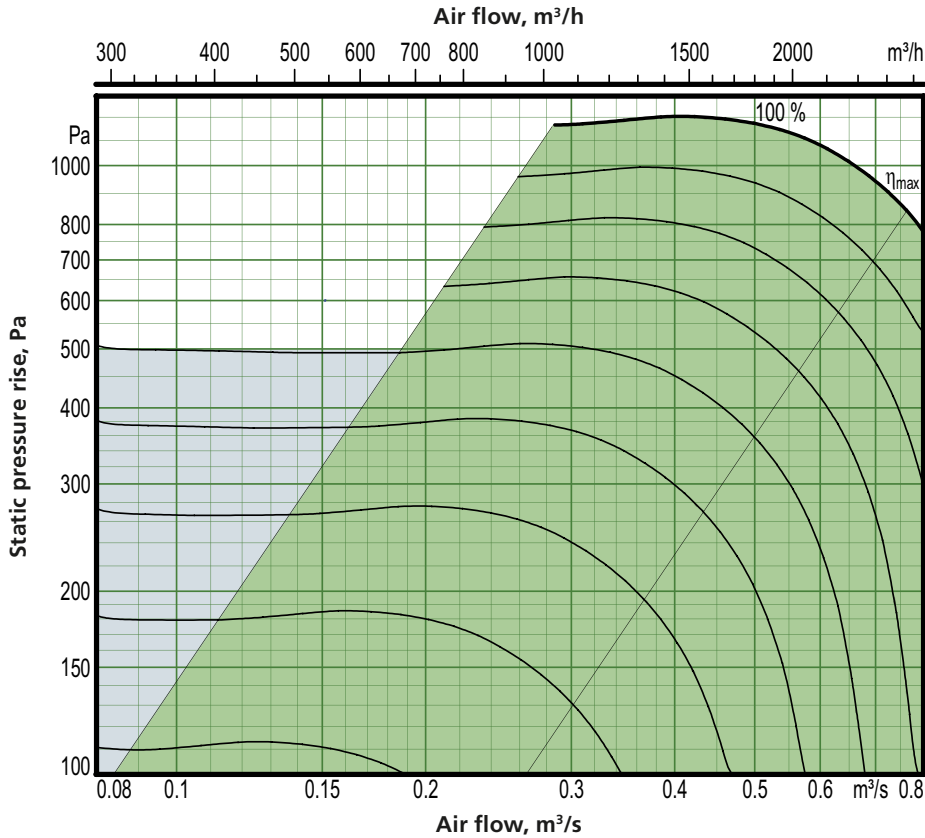

Motor shaft power: 1.15 kW (capacity variant 2)

- Recommended working range for sizing.
- If pressure regulation is used, the air flow can be regulated to zero.
- However this presupposes a certain static pressure drop in the ducting (approx. 50 Pa).

Min. and max. air flows

The flows specified refer to those that can be preset in the hand-held terminal. The practical flow limits are determined by the external pressure drop.

Size	Min. airflow (on airflow regulation)		Max. airflow	
	m ³ /h	m ³ /s	m ³ /h	m ³ /s
007	288	0.08	2700	0.75

Exact sizing can be carried out in the AHU Design air handling unit selection program

Sizing, installation, dimensions and weights

GOLD PX, counterflow heat exchanger, size 007, common casing

Delivery and transport within the site

The GOLD PX 007 is produced in one single variant. All of its components are arranged at their given physical locations inside the air handling unit.

The electrical cabinet and the drain pipe on the front of the air handling unit can be removed, if required, for transporting the unit within the building site.

The air handling unit is supplied on a wooden pallet.

The set of support legs, for mounting the base beams, is available as an accessory.

Duct connection options

A: Specify right-hand or left-hand version when ordering.

B: Specify whether the unit shall have an air intake from above for outdoor air and/or extract air when placing orders (does not apply to outdoor units).

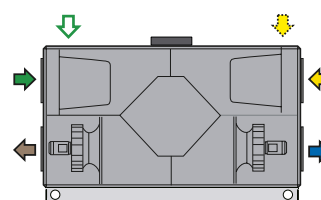

Right-hand version

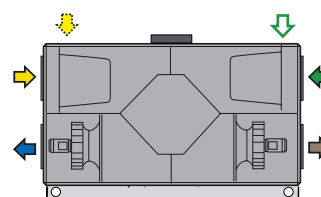

Left-hand version

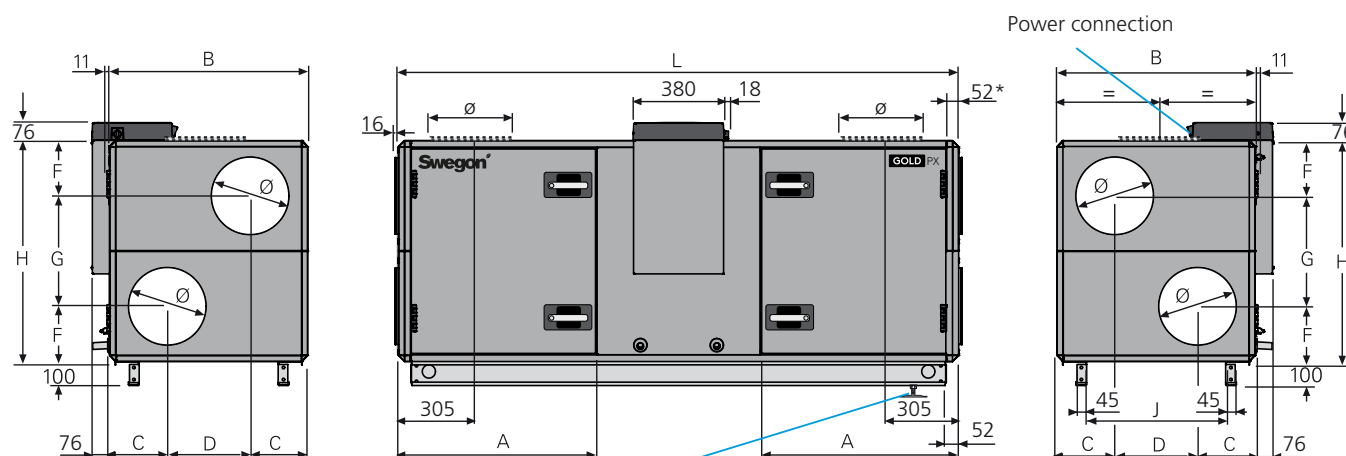

If a water trap (accessory) is fitted, the air handling unit must be raised at least 50 mm to provide space for the water trap. Support feet (accessories) can be used for this purpose.

* The air handling unit is supplied without end connection panel if a duct accessory housed in an insulated casing will be connected. The AHU can also be supplied with full face end connection panel (accessory).

Size	A	B	C	D	F	G	H	J	L	Ø	Weight, kg
007	911,5	995	277,5	440	271	543	1085	749	2503	400	435-492

Clear space for inspection

A clear space of 900 mm should be provided in front of the unit and at least 200 mm should be provided above the junction hood.

Power connection

Capacity variant 1:

1-phase, 3-conductor, 230 V -10/+15%, 50 Hz, 10 A or
3-phase, 5-conductor, 400 V -10/+15%, 50 Hz, 10 A

Capacity variant 2:

1-phase, 3-conductor, 230 V -10/+15%, 50 Hz, 16 A or
3-phase, 5-conductor, 400 V -10/+15%, 50 Hz, 10 A

Rated data per fan

Motor shaft power: 1.15 kW (0.8 kW* or 1.15 kW),
motor control system: 1 x 230 V, 50 Hz

*The motor control system limits the output power to the value specified.

Sizing, installation, dimensions and weights

GOLD PX, counterflow heat exchanger, size 007, split version

Delivery and transport within the site

The GOLD PX 007 can be supplied as one single unit, or in a number of different combinations of unit sections from the factory, see the section: Description of the Air Handling Unit/ Delivery Configuration RX/PX/CX, sizes 004-080.

The unit sections are jointed together/split by means of bolts. The electrical and control cables between the unit sections have quick-fit connectors.

The air handling unit/unit sections is/are delivered on wooden beams.

The electrical cabinet and the drain pipe on the front of the air handling unit can be removed, if required, for transporting the unit within the building site.

Duct connection options

A: Specify right-hand or left-hand version when ordering.

B: Specify whether the unit shall have an air intake from above for outdoor air and/or extract air when placing orders (does not apply to outdoor units).

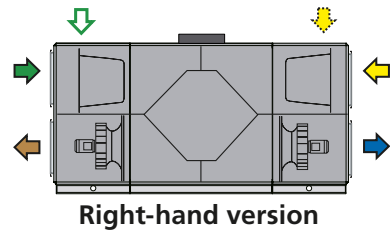

Right-hand version

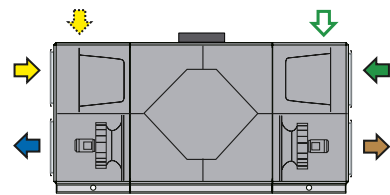

Left-hand version

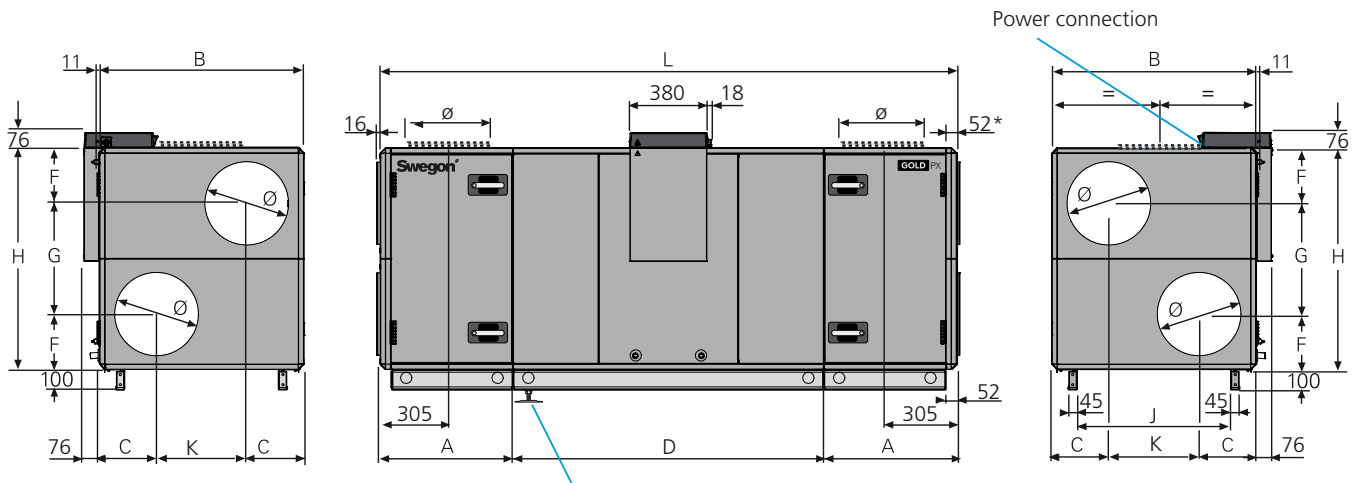

If a water trap (accessory) is fitted, the air handling unit must be raised at least 50 mm to provide space for the water trap. Support feet (accessories) can be used for this purpose.

* The air handling unit is supplied without end connection panel if a duct accessory housed in an insulated casing will be connected. The AHU can also be supplied with full face end connection panel (accessory).

Size	A	B	C	D	F	G	H	J	K	L	Ø	Weight, kg
007	647	995	277.5	1517	271	543	1085	749	440	2811	400	547-623

Division into sections for transport

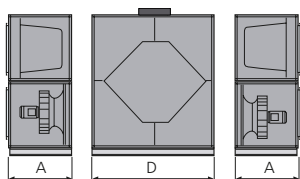

The unit can be divided into three sections at the building site.

Dimensions: See A and D in the table above.

Weight: A = 103-138 kg, D = 341-347 kg.

Clear space for inspection

A clear space of 900 mm should be provided in front of the unit and at least 200 mm should be provided above the junction hood.

Power connection

Capacity variant 1:

1-phase, 3-wire, 230 V -10/+15%, 50 Hz, 10 A or 3-phase, 5-wire, 400 V -10/+15%, 50 Hz, 10 A

Capacity variant 2:

1-phase, 3-wire, 230 V -10/+15%, 50 Hz, 16 A or 3-phase, 5-wire, 400 V -10/+15%, 50 Hz, 10 A

Rated data per fan

Motor shaft power: 1.15 kW (0.8 kW* or 1.15 kW), motor control system: 1 x 230 V, 50 Hz

*The motor control system limits the output power to the value specified.

Sizing, installation, dimensions and weights

GOLD PX Top, counterflow heat exchanger, size 007

Delivery and transport within the site

GOLD PX Top 007 can be supplied as one single unit or in an optional division of sections. Extra air handling unit sections cannot be ordered due to the deviating height measurement. Filter/fan sections for height adapted PX (side fed) and PX Top can be combined, see the section: Description of the Air Handling Unit.

The unit sections are jointed together/split by means of bolts. The electrical and control cables between the unit sections have quick-fit connectors.

The air handling unit/unit sections is/are delivered on wooden beams.

The electrical cabinet and the drain pipe on the front of the air handling unit can be removed, if required, for transporting the unit within the building site.

Duct connection options

A: All the duct connections are arranged from the top of the air handling unit (the unit must not be installed outdoors).

B: Specify right-hand or left-hand version when ordering.

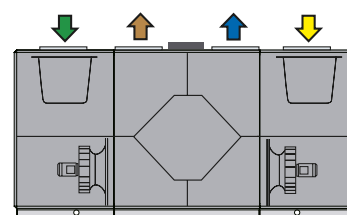

Right-hand version

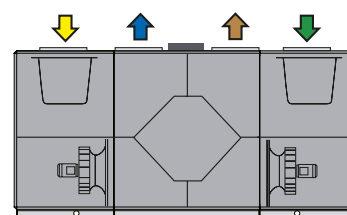

Left-hand version

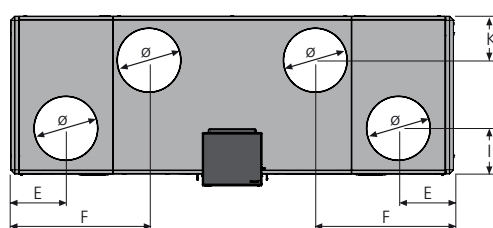
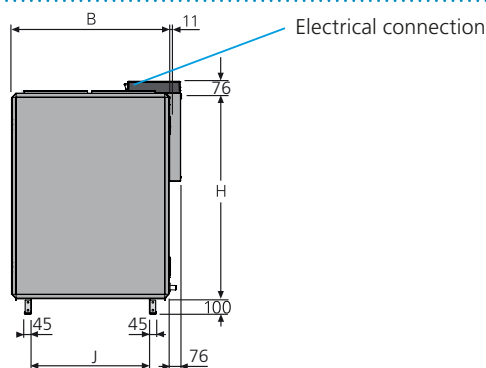
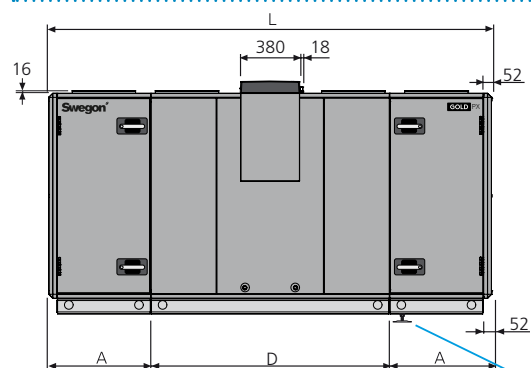

If a water trap (accessory) is fitted, the air handling unit must be raised at least 50 mm to provide space for the water trap. Support feet (accessories) can be used for this purpose.

Size	A	B	D	E	F	H	I	J	K	L	Ø	Weight, kg
007	647	995	1517	350	878	1295	288	749	278	2811	400	599-613

Division into sections for transport

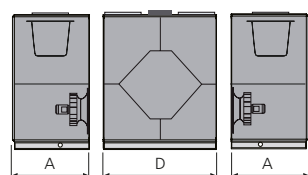

The unit can be divided into three sections at the building site.

Dimensions: See A and D in the table above.

Weight: A = 129-133 kg, D = 341-347 kg.

Clear space for inspection

A clear space of 900 mm should be provided in front of the unit and at least 200 mm should be provided above the junction hood.

Electrical connection

Capacity variant 1:

1-phase, 3-wire, 230 V -10/+15%, 50 Hz, 10 A or 3-phase, 5-wire, 400 V -10/+15%, 50 Hz, 10 A

Capacity variant 2:

1-phase, 3-wire, 230 V -10/+15%, 50 Hz, 16 A or 3-phase, 5-wire, 400 V -10/+15%, 50 Hz, 10 A

Rated data per fan

Motor shaft power: 1.15 kW (0.8 kW* or 1.15 kW), motor control system: 1 x 230 V, 50 Hz

*The motor control system limits the output power to the value specified.

Sizing, installation, dimensions and weights

GOLD PX, counterflow heat exchanger, size 008

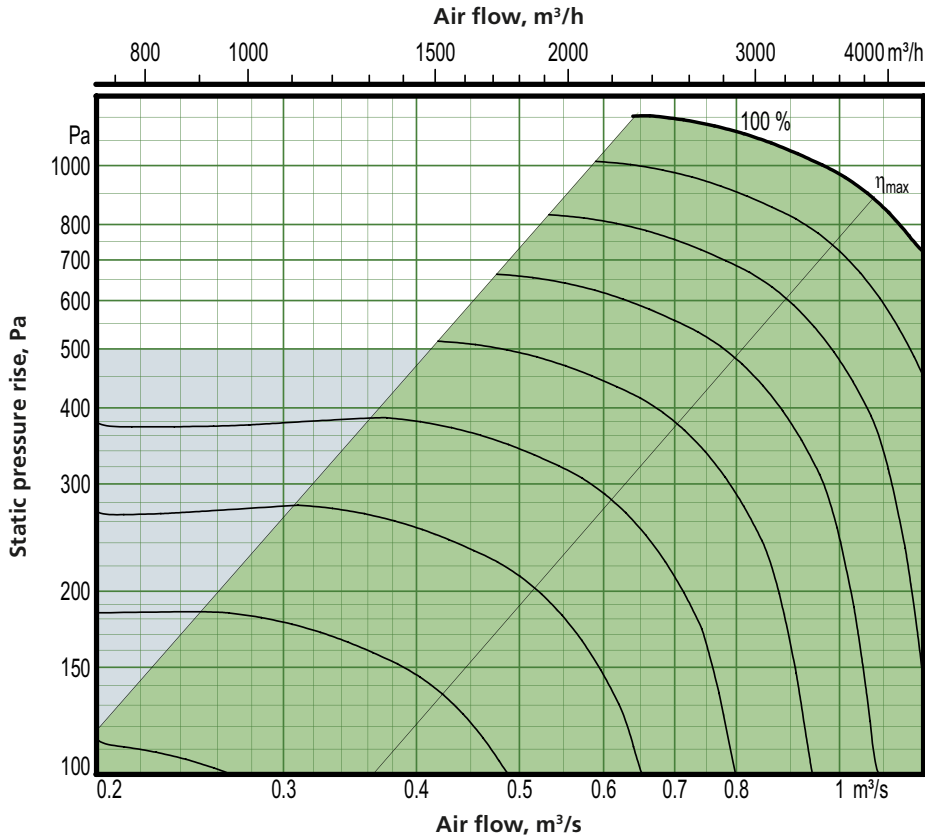

Motor shaft power: 1.6 kW (capacity variant 2)

- Recommended working range for sizing.
- If pressure regulation is used, the air flow can be regulated to zero.
- However this presupposes a certain static pressure drop in the ducting (approx. 50 Pa).

Min. and max. air flows

The flows specified refer to those that can be preset in the hand-held terminal. The practical flow limits are determined by the external pressure drop.

Size	Min. airflow (on airflow regulation)		Max. airflow	
	m ³ /h	m ³ /s	m ³ /h	m ³ /s
008	720	0.20	3600	1.00

Exact sizing can be carried out in the AHU Design air handling unit selection program

Sizing, installation, dimensions and weights

GOLD PX, counterflow heat exchanger, size 008, common casing

Delivery and transport within the site

The GOLD PX 008 is produced in one single variant. All of its components are arranged at their given physical locations inside the air handling unit.

The electrical cabinet and the drain pipe on the front of the air handling unit can be removed, if required, for transporting the unit within the building site.

The air handling unit is supplied on a wooden pallet.

The set of support legs, for mounting the base beams, is available as an accessory.

Duct connection options

A: Specify right-hand or left-hand version when ordering.

B: Specify whether the unit shall have an air intake from above for outdoor air and/or extract air when placing orders (does not apply to outdoor units).

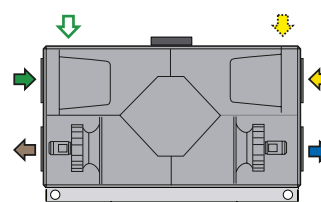

Right-hand version

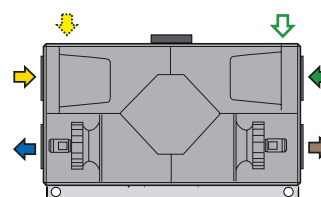

Left-hand version

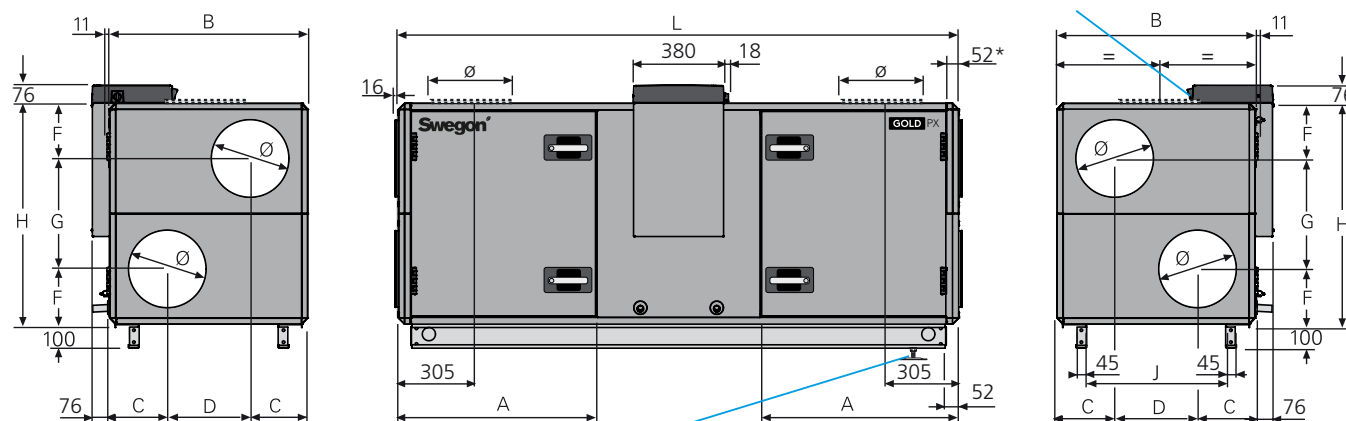
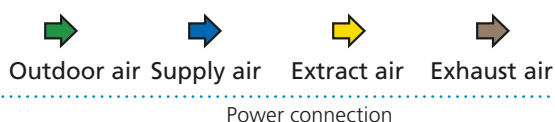

If a water trap (accessory) is fitted, the air handling unit must be raised at least 50 mm to provide space for the water trap. Support feet (accessories) can be used for this purpose.

* The air handling unit is supplied without end connection panel if a duct accessory housed in an insulated casing will be connected. The AHU can also be supplied with full face end connection panel (accessory).

Size	A	B	C	D	F	G	H	J	L	Ø	Weight, kg
008	911,5	995	277,5	440	271	543	1085	749	2503	400	449-506

Clear Space for Inspection

A clear space of 900 mm must be provided in front of the unit and at least 200 mm must be provided above the junction hood.

Power connection

Capacity variant 1:

1-phase, 3-wire, 230 V -10/+15%, 50 Hz, 16 A or 3-phase, 5-wire, 400 V -10/+15%, 50 Hz, 10 A

Capacity variant 2:

3-phase, 5-wire, 400 V -10/+15%, 50 Hz, 10 A

Rated data per fan

Capacity variant 1:

Motor shaft power: 1.15 kW, motor control system: 1 x 230 V, 50 Hz

Capacity variant 2:

Motor shaft power: 1.6 kW, motor control system: 3 x 400 V, 50 Hz

Sizing, installation, dimensions and weights

GOLD PX, counterflow heat exchanger, size 008, split version

Delivery and transport within the site

The GOLD PX 008 can be supplied as one single unit, or in a number of different combinations of unit sections from the factory, see the section: Description of the Air Handling Unit/ Delivery Configuration RX/PX/CX, sizes 004-080.

The unit sections are jointed together/split by means of bolts. The electrical and control cables between the unit sections have quick-fit connectors.

The air handling unit/unit sections is/are delivered on wooden beams.

The electrical cabinet and the drain pipe on the front of the air handling unit can be removed, if required, for transporting the unit within the building site.

Duct connection options

A: Specify right-hand or left-hand version when ordering.

B: Specify whether the unit shall have an air intake from above for outdoor air and/or extract air when placing orders (does not apply to outdoor units).

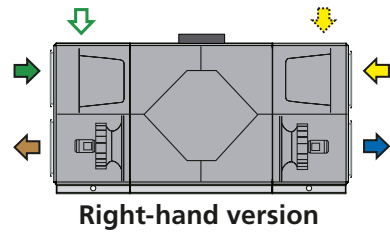

Right-hand version

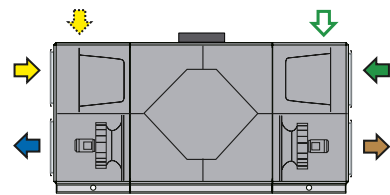

Left-hand version

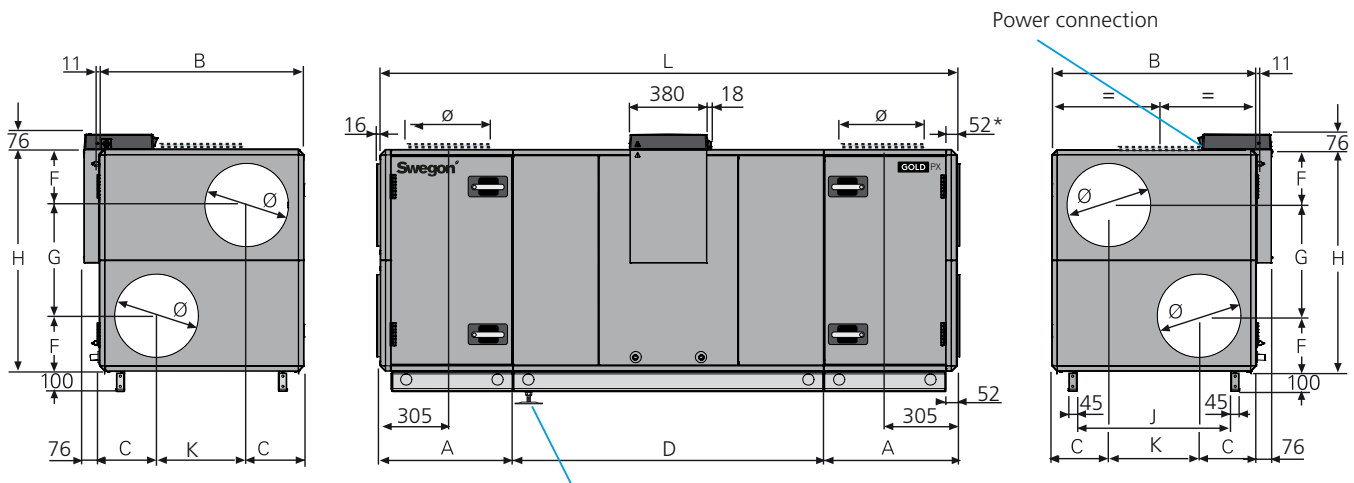
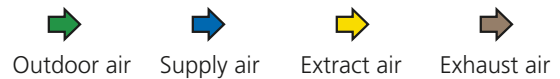

If a water trap (accessory) is fitted, the air handling unit must be raised at least 50 mm to provide space for the water trap. Support feet (accessories) can be used for this purpose.

* The air handling unit is supplied without end connection panel if a duct accessory housed in an insulated casing will be connected. The AHU can also be supplied with full face end connection panel (accessory).

Size	A	B	C	D	F	G	H	J	K	L	Ø	Weight, kg
008	647	995	277.5	1517	271	543	1085	749	440	2811	400	561-631

Division into sections for transport

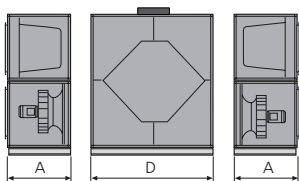

The unit can be divided into three sections at the building site.

Dimensions: See A and D in the table above.

Weight: A = 110-142 kg, D = 341-347 kg.

Clear space for inspection

A clear space of 900 mm should be provided in front of the unit and at least 200 mm should be provided above the junction hood.

Power connection

Capacity variant 1:

1-phase, 3-wire, 230 V -10/+15%, 50 Hz, 16 A or 3-phase, 5-wire, 400 V -10/+15%, 50 Hz, 10 A

Capacity variant 2:

3-phase, 5-wire, 400 V -10/+15%, 50 Hz, 10 A

Rated data per fan

Capacity variant 1:

Motor shaft power: 1.15 kW, motor control system: 1 x 230 V, 50 Hz

Capacity variant 2:

Motor shaft power: 1.6 kW, motor control system: 3 x 400 V, 50 Hz

Sizing, installation, dimensions and weights

GOLD PX Top, counterflow heat exchanger, size 008

Delivery and transport within the site

GOLD PX Top 008 can be supplied as one single unit or in an optional division of sections. Extra air handling unit sections cannot be ordered due to the deviating height measurement. Filter/fan sections for height adapted PX (side fed) and PX Top can be combined, see the section: Description of the Air Handling Unit.

The unit sections are jointed together/split by means of bolts. The electrical and control cables between the unit sections have quick-fit connectors.

The air handling unit/unit sections is/are delivered on wooden beams.

The electrical cabinet and the drain pipe on the front of the air handling unit can be removed, if required, for transporting the unit within the building site.

Duct connection options

A: All the duct connections are arranged from the top of the air handling unit (the unit must not be installed outdoors).

B: Specify right-hand or left-hand version when ordering.

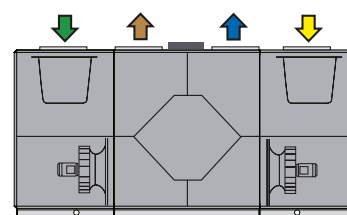

Right-hand version

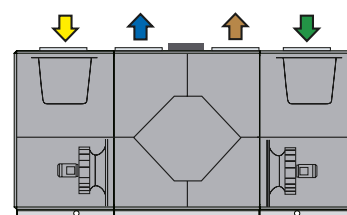

Left-hand version

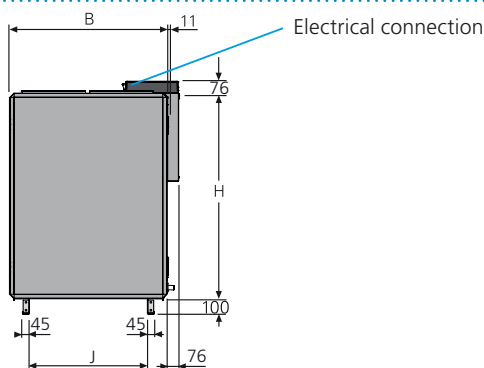
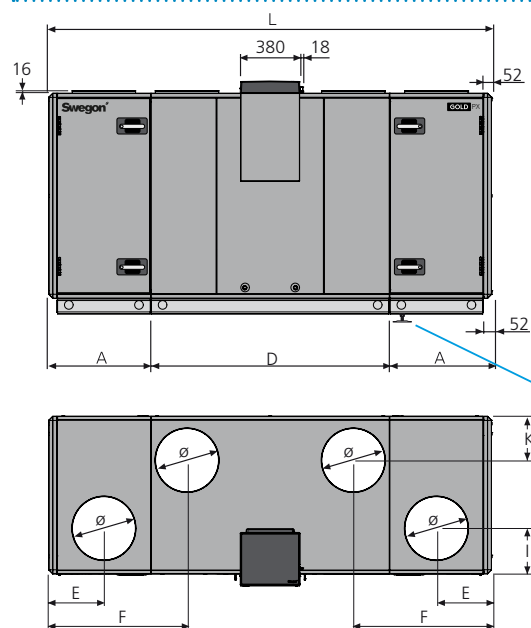

If a water trap (accessory) is fitted, the air handling unit must be raised at least 50 mm to provide space for the water trap. Support feet (accessories) can be used for this purpose.

Size	A	B	D	E	F	H	I	J	K	L	∅	Weight, kg
008	647	995	1517	350	878	1295	288	749	278	2811	400	613-621

Division into sections for transport

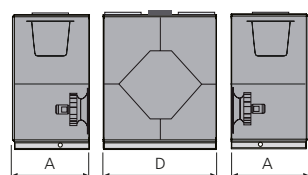

The unit can be divided into three sections at the building site.

Dimensions: See A and D in the table above.

Weight: A = 136-137 kg, D = 341-347 kg.

Clear space for inspection

A clear space of 900 mm should be provided in front of the unit and at least 200 mm should be provided above the junction hood.

Electrical connection

Capacity variant 1:

1-phase, 3-wire, 230 V -10/+15%, 50 Hz, 16 A or 3-phase, 5-wire, 400 V -10/+15%, 50 Hz, 10 A

Capacity variant 2:

3-phase, 5-wire, 400 V -10/+15%, 50 Hz, 10 A

Rated data per fan

Capacity variant 1:

Motor shaft power: 1.15 kW, motor control system: 1 x 230 V, 50 Hz

Capacity variant 2:

Motor shaft power: 1.6 kW, motor control system: 3 x 400 V, 50 Hz

Sizing, installation, dimensions and weights

GOLD PX, counterflow heat exchanger, size 011

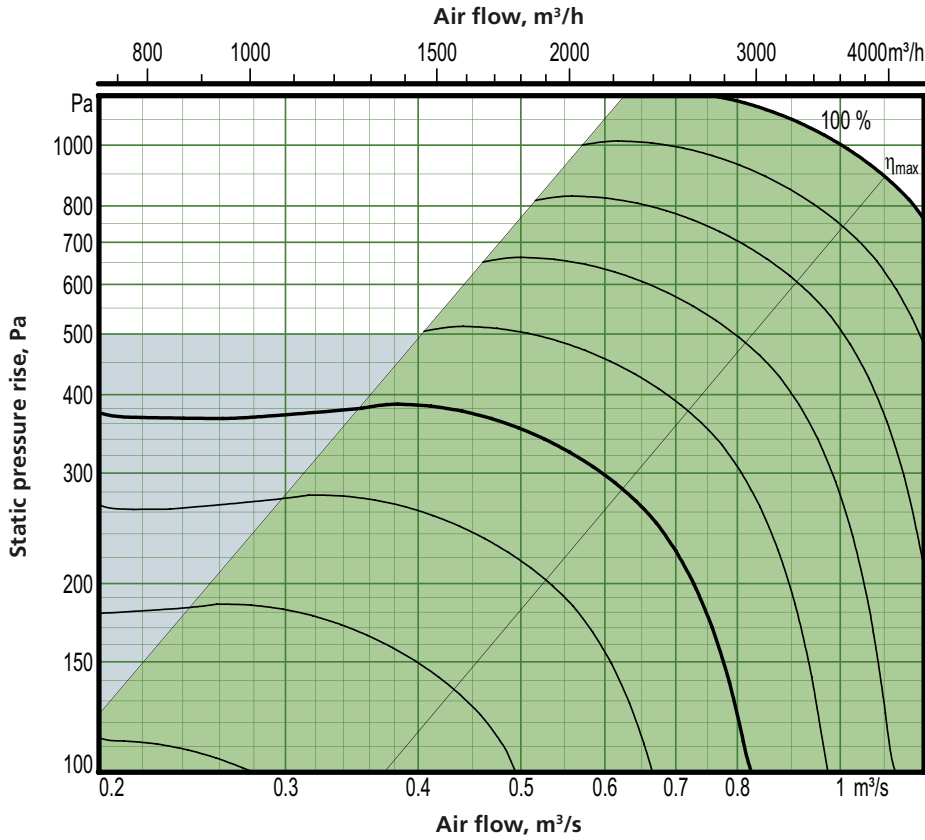

Motor shaft power: 1.6 kW (capacity variant 2)

- Recommended working range for sizing.
- If pressure regulation is used, the air flow can be regulated to zero.
- However this presupposes a certain static pressure drop in the ducting (approx. 50 Pa).

Min. and max. air flows

The flows specified refer to those that can be preset in the hand-held terminal. The practical flow limits are determined by the external pressure drop.

Size	Min. airflow (on airflow regulation)		Max. airflow	
	m ³ /h	m ³ /s	m ³ /h	m ³ /s
011	720	0.20	3960	1.10

Exact sizing can be carried out in the AHU Design air handling unit selection program

Sizing, installation, dimensions and weights

GOLD PX, counterflow heat exchanger, size 011

Delivery and transport within the site

The GOLD PX 011 can be supplied as one single unit, or in a number of different combinations of unit sections from the factory, see the section: Description of the Air Handling Unit. Filter/fan sections for PX and PX Top can be combined, see the section: Description of the Air Handling Unit.

The unit sections are jointed together/split by means of bolts. The electrical and control cables between the unit sections have quick-fit connectors.

The air handling unit/unit sections is/are delivered on wooden beams.

The electrical cabinet and the drain pipe on the front of the air handling unit can be removed, if required, for transporting the unit within the building site.

Duct connection options

A: Specify right-hand or left-hand version when ordering.

B: Specify whether the unit shall have an air intake from above for outdoor air and/or extract air when placing orders (does not apply to outdoor units).

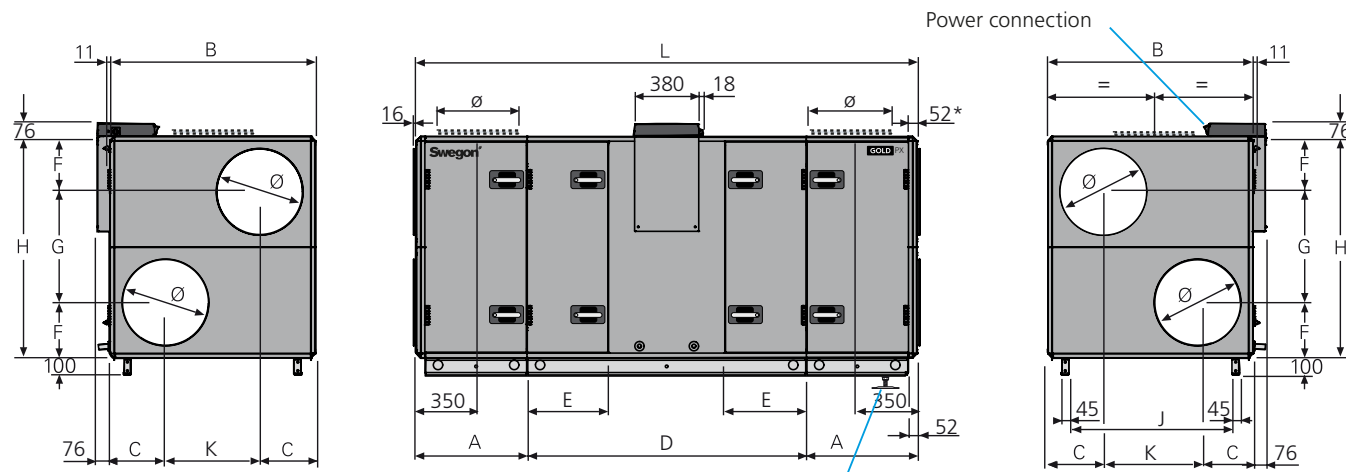
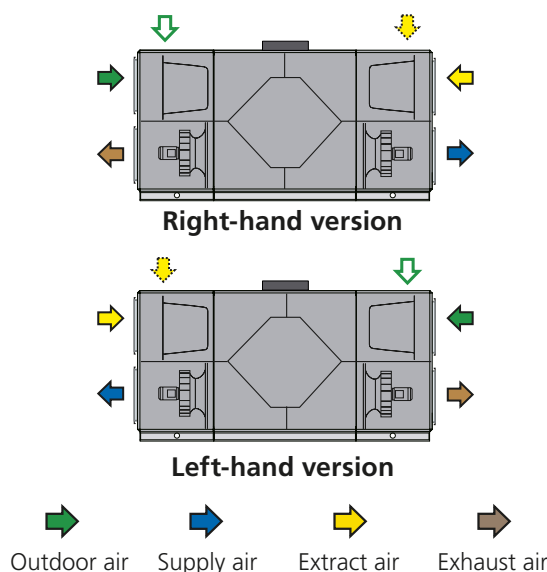

If a water trap (accessory) is fitted, the air handling unit must be raised at least 50 mm to provide space for the water trap. Support feet (accessories) can be used for this purpose.

* The air handling unit is supplied without end connection panel if a duct accessory housed in an insulated casing will be connected. The AHU can also be supplied with full face end connection panel (accessory).

Size	A	B	C	D	E	F	G	H	J	K	L	Ø	Weight, kg
011	647	1199	324	1631	471	324	647	1295	953	551	2925	500	714-804

Division into sections for transport

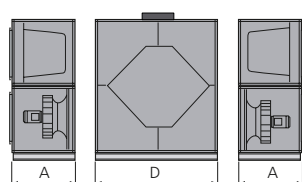

The unit can be divided into three sections at the building site.

Dimensions: See A and D in the table above.

Weight: A = 135-175 kg, D = 444-454 kg.

Power connection

Capacity variant 1:

1-phase, 3-conductor, 230 V -10/+15%, 50 Hz, 16 A or 3-phase, 5-conductor, 400 V -10/+15%, 50 Hz, 10 A

Capacity variant 2:

3-phase, 5-conductor, 400 V -10/+15%, 50 Hz, 10 A

Rated data per fan

Capacity variant 1:

Motor shaft power: 1.15 kW, motor control system: 1 x 230 V, 50 Hz

Capacity variant 2:

Motor shaft power: 1.6 kW, motor control system: 3 x 400 V, 50 Hz

Clear space for inspection

A clear space of 900 mm should be provided in front of the unit and at least 200 mm should be provided above the junction hood.

Sizing, installation, dimensions and weights

GOLD PX Top, counterflow heat exchanger, size 011

Delivery and transport within the site

The GOLD Top PX 011 can be supplied as two units, or in a number of different combinations of unit sections from the factory, see the section: Description of the Air Handling Unit. Filter/fan sections for PX and PX Top can be combined, see the section: Description of the Air Handling Unit. The unit sections are jointed together/split by means of bolts. The electrical and control cables between the unit sections have quick-fit connectors. The air handling unit/unit sections is/are delivered on wooden beams. The electrical cabinet and the drain pipe on the front of the air handling unit can be removed, if required, for transporting the unit within the building site.

Duct connection options

A: All the duct connections are arranged from the top of the air handling unit (the unit must not be installed outdoors).
B: Specify right-hand or left-hand version when ordering.

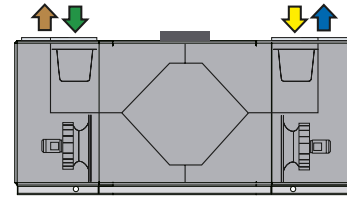

Right-hand version

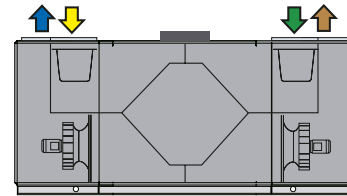

Left-hand version

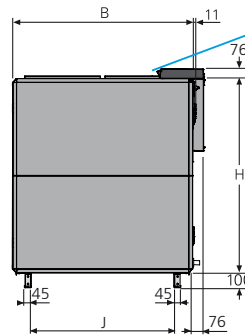
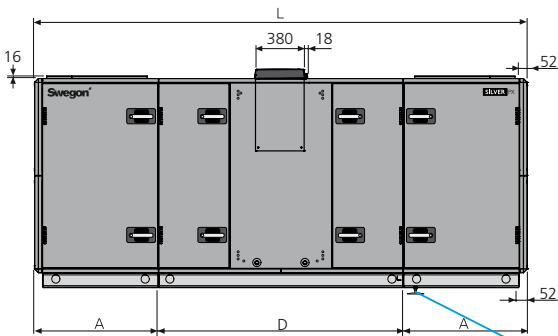
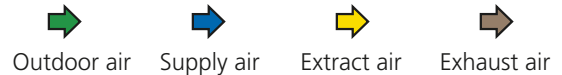

Electrical connection

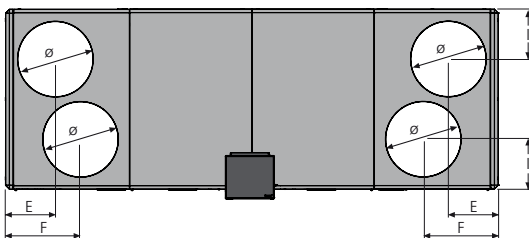

If a water trap (accessory) is fitted, the air handling unit must be raised at least 50 mm to provide space for the water trap. Support feet (accessories) can be used for this purpose.

Size	A	B	D	E	F	H	I	J	L	Ø	Weight, kg
011	827	1199	1631	332	500	1295	332	953	3285	500	814-826

Division into sections for transport

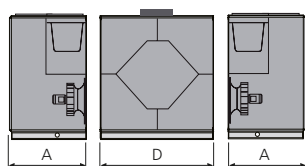

The unit can be divided into three sections at the building site.
Dimensions: See A and D in the table above.
Weight: A = 185-186 kg, D = 444-454 kg.

Clear space for inspection

A clear space of 900 mm should be provided in front of the unit and at least 200 mm should be provided above the junction hood.

Electrical connection

Capacity variant 1:
 1-phase, 3-wire, 230 V -10/+15%, 50 Hz, 16 A or
 3-phase, 5-wire, 400 V -10/+15%, 50 Hz, 10 A
Capacity variant 2:
 3-phase, 5-wire, 400 V -10/+15%, 50 Hz, 10 A

Rated data per fan

Capacity variant 1:
 Motor shaft power: 1.15 kW, motor control system: 1 x 230 V, 50 Hz
Capacity variant 2:
 Motor shaft power: 1.6 kW, motor control system: 3 x 400 V, 50 Hz

Sizing, installation, dimensions and weights

GOLD PX, counterflow heat exchanger, size 012

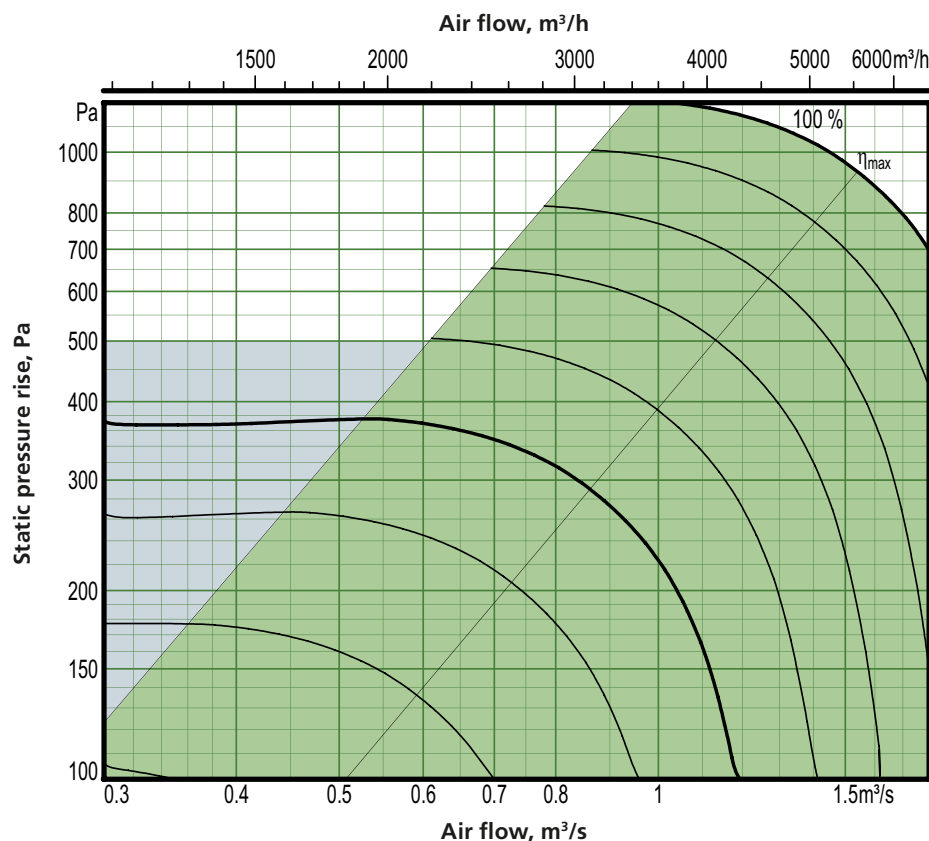

Motor shaft power: 2.4 kW (capacity variant 2)

- Recommended working range for sizing.
- If pressure regulation is used, the air flow can be regulated to zero.
- However this presupposes a certain static pressure drop in the ducting (approx. 50 Pa).

Min. and max. air flows

The flows specified refer to those that can be preset in the hand-held terminal. The practical flow limits are determined by the external pressure drop.

Size	Min. airflow (on airflow regulation)		Max. airflow	
	m³/h	m³/s	m³/h	m³/s
012	720	0.20	5040	1.40

Exact sizing can be carried out in the AHU Design air handling unit selection program

Sizing, installation, dimensions and weights

GOLD PX, counterflow heat exchanger, size 012

Delivery and transport within the site

The GOLD PX 012 can be supplied as one single unit, or in a number of different combinations of unit sections from the factory, see the section: Description of the Air Handling Unit. Filter/fan sections for PX and PX Top can be combined, see the section: Description of the Air Handling Unit. The unit sections are jointed together/split by means of bolts. The electrical and control cables between the unit sections have quick-fit connectors. The air handling unit/unit sections is/are delivered on wooden beams.

The electrical cabinet and the drain pipe on the front of the air handling unit can be removed, if required, for transporting the unit within the building site.

Duct connection options

- A:** Specify right-hand or left-hand version when ordering.
- B:** Specify whether the unit shall have an air intake from above for outdoor air and/or extract air when placing orders (does not apply to outdoor units).

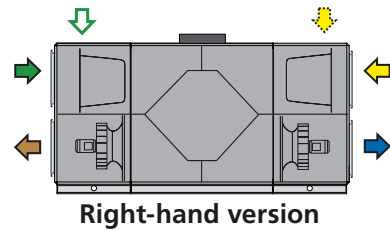

Right-hand version

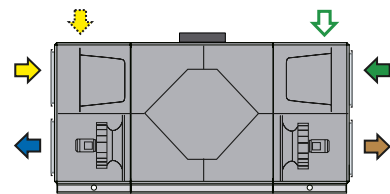

Left-hand version

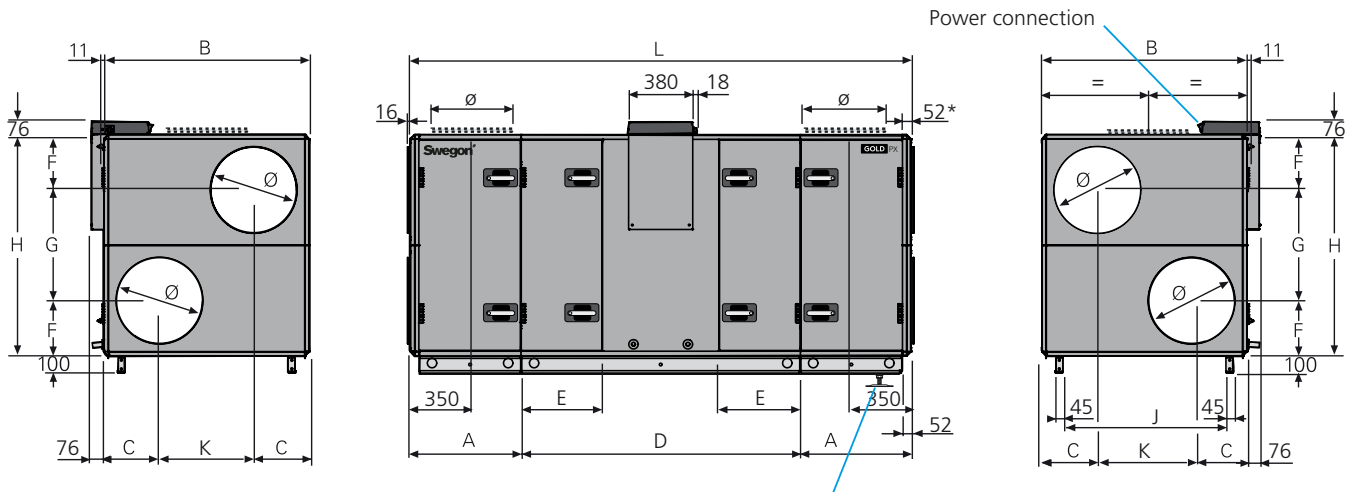

If a water trap (accessory) is fitted, the air handling unit must be raised at least 50 mm to provide space for the water trap. Support feet (accessories) can be used for this purpose.

* The air handling unit is supplied without end connection panel if a duct accessory housed in an insulated casing will be connected. The AHU can also be supplied with full face end connection panel (accessory).

Size	A	B	C	D	E	F	G	H	J	K	L	Ø	Weight, kg
012	647	1199	324	1631	471	324	647	1295	953	551	2925	500	736-832

Division into sections for transport

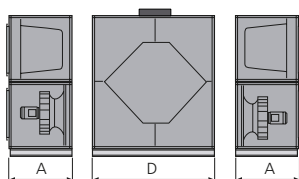

The unit can be divided into three sections at the building site.
Dimensions: See A and D in the table above.
Weight: A = 146-189 kg, D = 444-454 kg.

Clear space for inspection

A clear space of 900 mm should be provided in front of the unit and at least 200 mm should be provided above the junction hood.

Power connection

3-phase, 5-wire, 400 V -10/+15%, 50 Hz, 10 A

Rated data per fan

Motor shaft power: 2.4 kW (1.6 kW* or 2.4 kW), motor control system: 3 x 400 V, 50 Hz

*The motor control system limits the output power to the value specified.

Sizing, installation, dimensions and weights

GOLD PX Top, counterflow heat exchanger, size 012

Delivery and transport within the site

The GOLD Top PX 012 can be supplied as two units, or in a number of different combinations of unit sections from the factory, see the section: Description of the Air Handling Unit. Filter/fan sections for PX and PX Top can be combined, see the section: Description of the Air Handling Unit.

The unit sections are jointed together/split by means of bolts. The electrical and control cables between the unit sections have quick-fit connectors.

The air handling unit/unit sections is/are delivered on wooden beams.

The electrical cabinet and the drain pipe on the front of the air handling unit can be removed, if required, for transporting the unit within the building site.

Duct connection options

A: All the duct connections are arranged from the top of the air handling unit (the unit must not be installed outdoors).

B: Specify right-hand or left-hand version when ordering.

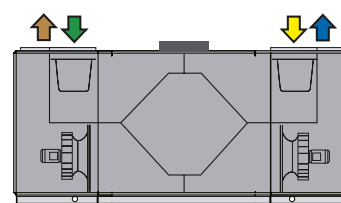

Right-hand version

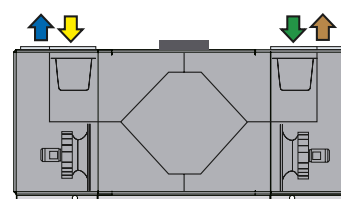

Left-hand version

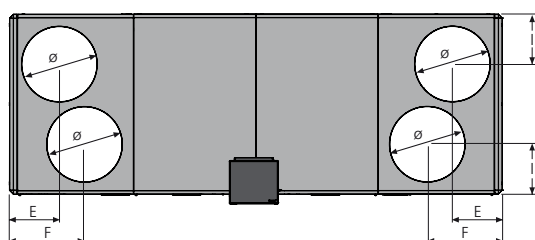
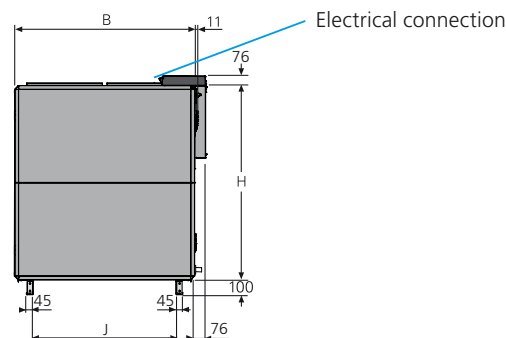
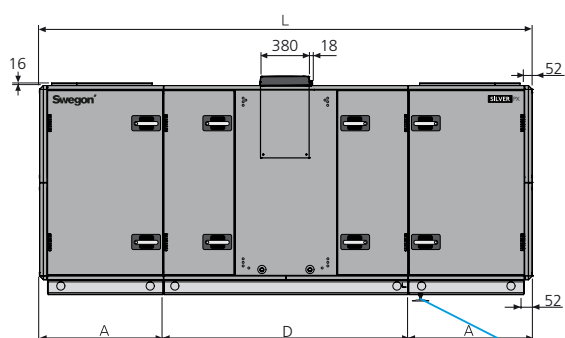
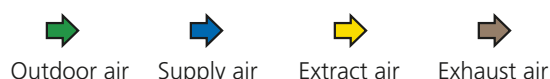

If a water trap (accessory) is fitted, the air handling unit must be raised at least 50 mm to provide space for the water trap. Support feet (accessories) can be used for this purpose.

Size	A	B	D	E	F	H	I	J	L	Ø	Weight, kg
012	827	1199	1631	332	500	1295	332	953	3285	500	836-854

Division into sections for transport

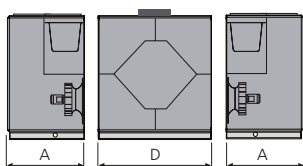

The unit can be divided into three sections at the building site.

Dimensions: See A and D in the table above.

Weight: A = 196-200 kg, D = 444-454 kg.

Clear space for inspection

A clear space of 900 mm should be provided in front of the unit and at least 200 mm should be provided above the junction hood.

Electrical connection

3-phase, 5-wire, 400 V -10/+15%, 50 Hz, 10 A

Rated data per fan

Motor shaft power: 2.4 kW (1.6 kW* or 2.4 kW), motor control system: 3 x 400 V, 50 Hz

*The motor control system limits the output power to the value specified.

Sizing, installation, dimensions and weights

GOLD PX, counterflow heat exchanger, size 014/020
 Size 014 (Extract air fan size 020 can be selected, see the next page)

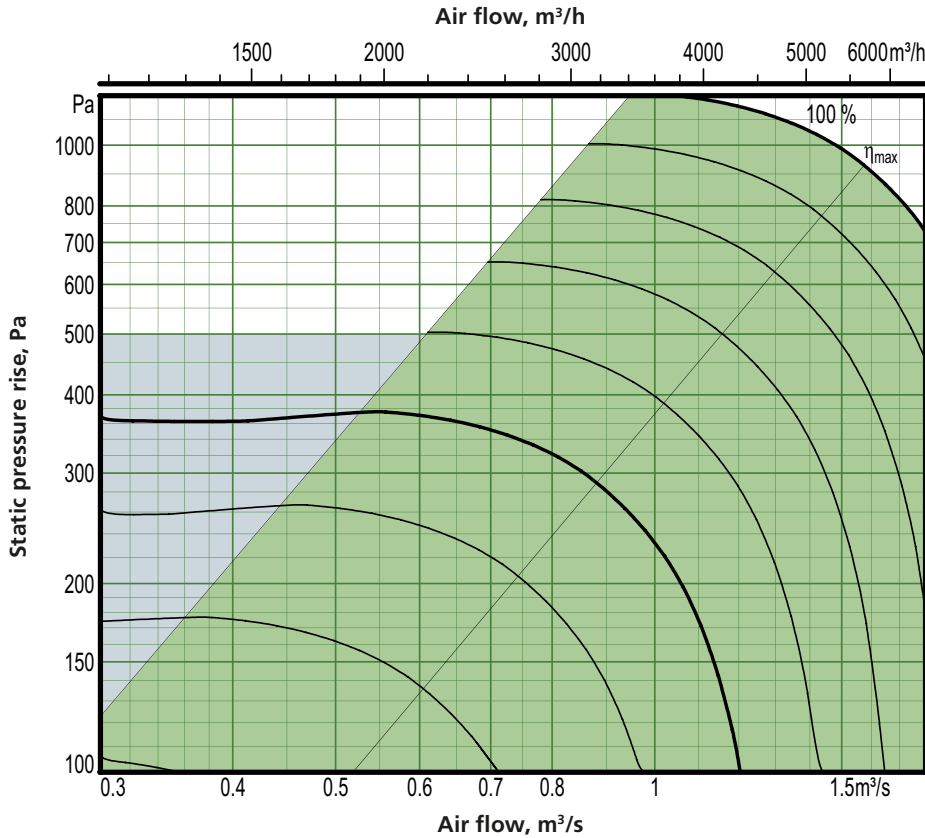

Motor shaft power: 2.4 kW (capacity variant 2)

- Recommended working range for sizing.
- If pressure regulation is used, the air flow can be regulated to zero.
- However this presupposes a certain static pressure drop in the ducting (approx. 50 Pa).

Min. and max. airflows

The flows specified refer to those that can be preset in the hand-held terminal. The practical flow limits are determined by the external pressure drop.

Size	Min. airflow (on airflow regulation)		Max. airflow	
	m ³ /h	m ³ /s	m ³ /h	m ³ /s
014	720	0.20	5940	1.65

Exact sizing can be carried out in the AHU Design air handling unit selection program

Sizing, installation, dimensions and weights

GOLD PX, counterflow heat exchanger, size 014/020

Size 020 (Extract air fan size 014 can be selected, see the previous page)

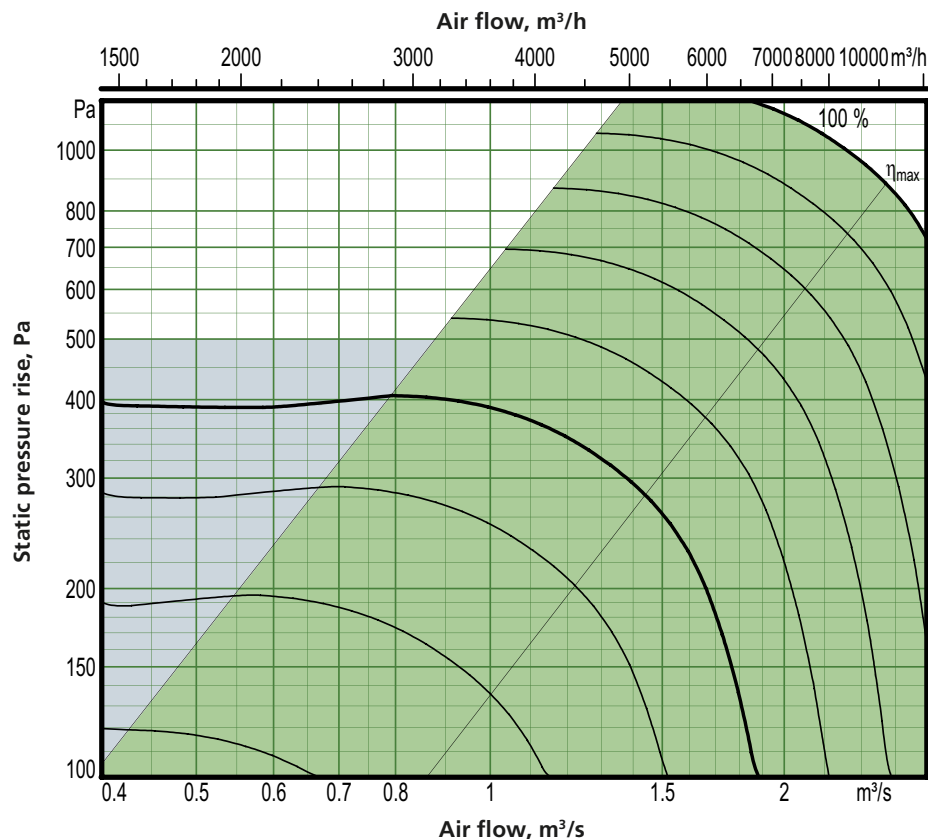

Motor shaft power: 3.4 kW (capacity variant 2)

- Recommended working range for sizing.
- If pressure regulation is used, the air flow can be regulated to zero.
- However this presupposes a certain static pressure drop in the ducting (approx. 50 Pa).

Min. and max. airflows

The flows specified refer to those that can be preset in the hand-held terminal. The practical flow limits are determined by the external pressure drop.

Size	Min. airflow (on airflow regulation)		Max. airflow	
	m³/h	m³/s	m³/h	m³/s
020	1080	0.30	7560	2.1

Exact sizing can be carried out in the AHU Design air handling unit selection program

Sizing, installation, dimensions and weights

GOLD PX, counterflow heat exchanger, size 014/020

Delivery and transport within the site

The GOLD PX 014/020 can be supplied as two units, or in a number of different combinations of unit sections from the factory, see the section: Description of the Air Handling Unit. Filter/fan sections for PX and PX Top can be combined, see the section: Description of the Air Handling Unit. The unit sections are jointed together/split by means of bolts. The electrical and control cables between the unit sections have quick-fit connectors. The air handling unit/unit sections is/are delivered on wooden beams. The electrical cabinet and the drain pipe on the front of the air handling unit can be removed, if required, for transporting the unit within the building site.

Duct connection options

- A:** Specify right-hand or left-hand version when ordering.
- B:** Specify whether the unit shall have an air intake from above for outdoor air and/or extract air when placing orders (does not apply to outdoor units).

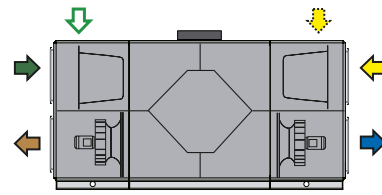

Right-hand version

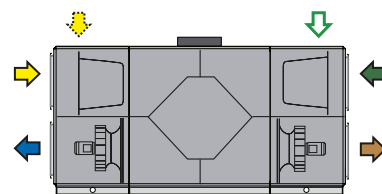

Left-hand version

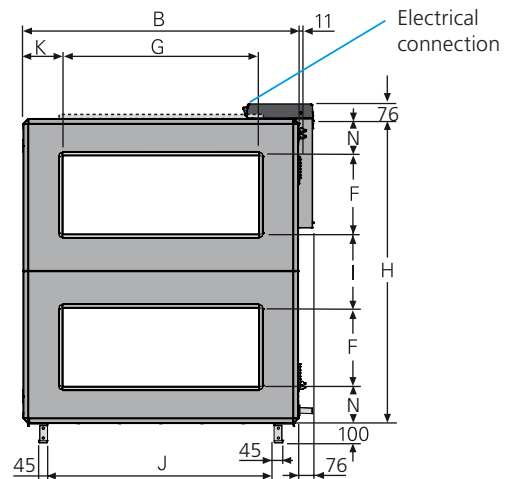
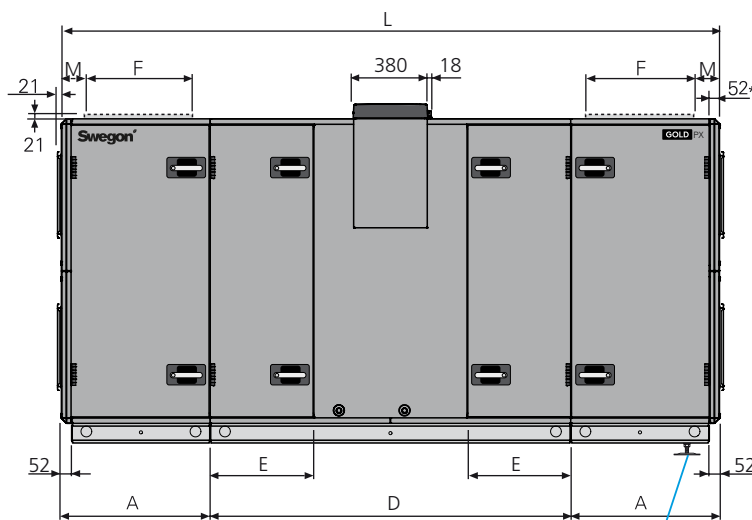

* The air handling unit is supplied without end connection panel if a duct accessory housed in an insulated casing will be connected. The AHU can also be supplied with full face end connection panel (accessory).

If a water trap (accessory) is fitted, the air handling unit must be raised at least 50 mm to provide space for the water trap. Support feet (accessories) can be used for this purpose.

Size	A	B	D	E	F	G	H	I	J	K	L	M	N	Weight, kg
014/020	757,5	1400	1836	528	400	1000	1551	375	1154	200	3351	205	188	929-1089

Division into sections for transport

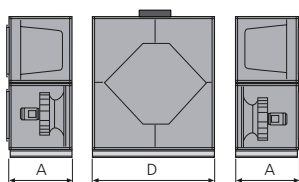

The unit can be divided into three sections at the building site.
Dimensions: See A and D in the table above.
Weight: A = 190-264 kg, D = 549-561 kg.

Rated data per fan

- Size 014: Motor shaft power: 2.4 kW (1.6 kW* or 2.4 kW), motor control system: 3 x 400 V, 50 Hz
 *The motor control system limits the output power to the value specified.
- Size 020: Motor shaft power: 2.4 kW alt. 3.4 kW, motor control system: 3 x 400 V, 50 Hz

Clear space for inspection

A clear space of 900 mm should be provided in front of the unit and at least 200 mm should be provided above the junction hood.

Electrical connection

See table Electrical data at the end of this section.

Sizing, installation, dimensions and weights

GOLD PX Top, counterflow heat exchanger, size 014/020

Delivery and transport within the site

The GOLD Top PX 014/020 can be supplied as two units, or in a number of different combinations of unit sections from the factory, see the section: Description of the Air Handling Unit. Filter/fan sections for PX and PX Top can be combined, see the section: Description of the Air Handling Unit.

The unit sections are jointed together/split by means of bolts. The electrical and control cables between the unit sections have quick-fit connectors.

The air handling unit/unit sections is/are delivered on wooden beams.

The electrical cabinet and the drain pipe on the front of the air handling unit can be removed, if required, for transporting the unit within the building site.

Duct connection options

A: All the duct connections are arranged from the top of the air handling unit (the unit must not be installed outdoors).

B: Specify right-hand or left-hand version when ordering.

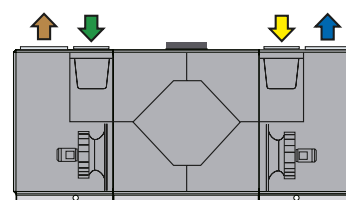

Right-hand version

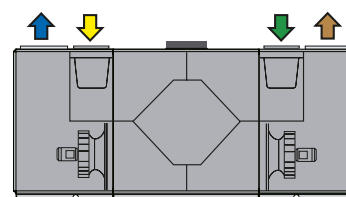

Left-hand version

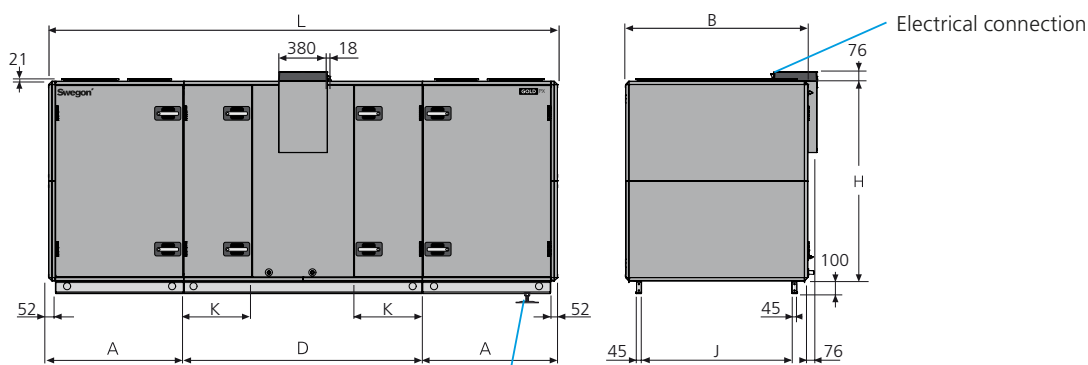

If a water trap (accessory) is fitted, the air handling unit must be raised at least 50 mm to provide space for the water trap. Support feet (accessories) can be used for this purpose.

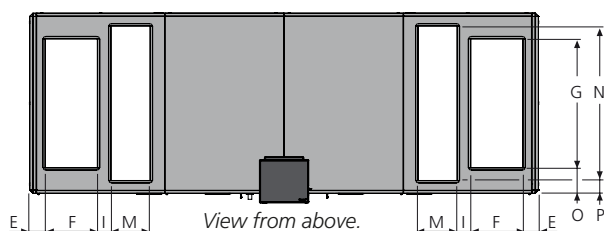

Size	A	B	D	E	F	G	H	I	J	K	L	M	N	O	P	Weight, kg
014/020	1039	1400	1836	120	400	1000	1551	106	1154	528	3914	300	1200	200	100	1083-1175

Division into sections for transport

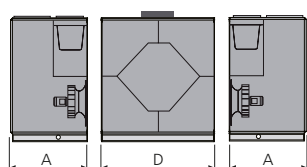

The unit can be divided into three sections at the building site.

Dimensions: See A and D in the table above.

Weight: A = 267-307 kg, D = 549-561 kg.

Rated data per fan

Size 014: Motor shaft power: 2.4 kW (1.6 kW* or 2.4 kW), motor control system: 3 x 400 V, 50 Hz
 *The motor control system limits the output power to the value specified.

Size 020: Motor shaft power: 2.4 kW alt. 3.4 kW, motor control system: 3 x 400 V, 50 Hz

Clear space for inspection

A clear space of 1000 mm should be provided in front of the unit and at least 200 mm should be provided above the junction hood.

Electrical connection

See table Electrical data at the end of this section.

Sizing, installation, dimensions and weights

GOLD PX, counterflow heat exchanger, size 025/030
 Size 025 (Extract air fan size 030 can be selected, see the next page)

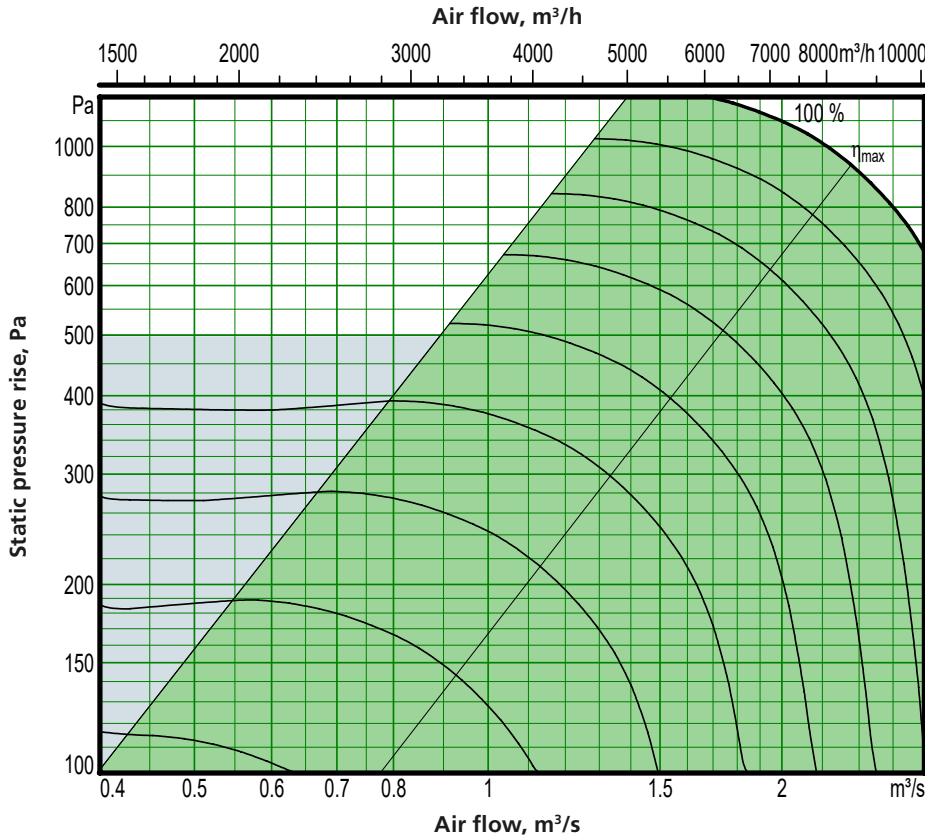

Motor shaft power: 3.4 kW (capacity variant 2)

- Recommended working range for sizing.
- If pressure regulation is used, the air flow can be regulated to zero.
- However this presupposes a certain static pressure drop in the ducting (approx. 50 Pa).

Min. and max. airflows

The flows specified refer to those that can be preset in the hand-held terminal. The practical flow limits are determined by the external pressure drop.

Size	Min. airflow (on airflow regulation)		Max. airflow	
	m³/h	m³/s	m³/h	m³/s
025	1080	0.30	9000	2.50

Exact sizing can be carried out in the AHU Design air handling unit selection program

Sizing, installation, dimensions and weights

GOLD PX, counterflow heat exchanger, size 025/030

Size 030 (Extract air fan size 025 can be selected, see the previous page)

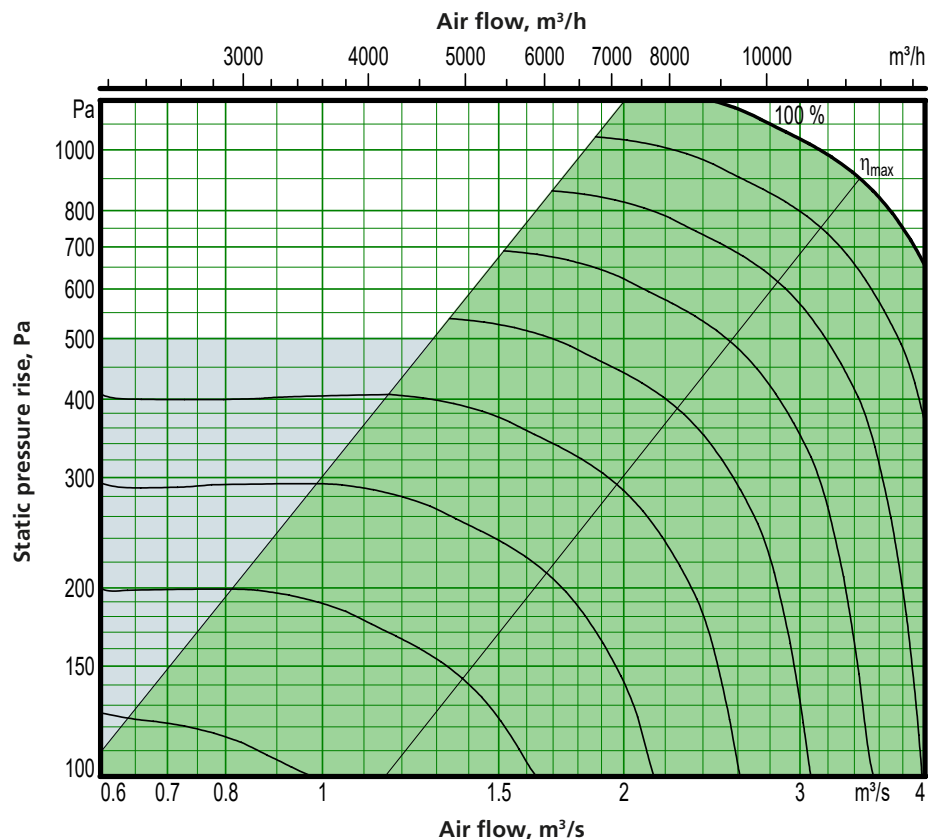

Motor shaft power: 5.0 kW (capacity variant 2)

- Recommended working range for sizing.
- If pressure regulation is used, the air flow can be regulated to zero.
- However this presupposes a certain static pressure drop in the ducting (approx. 50 Pa).

Min. and max. airflows

The flows specified refer to those that can be preset in the hand-held terminal. The practical flow limits are determined by the external pressure drop.

Size	Min. airflow (on airflow regulation)		Max. airflow	
	m ³ /h	m ³ /s	m ³ /h	m ³ /s
030	1800	0.50	11520	3.20

Exact sizing can be carried out in the AHU Design air handling unit selection program

Sizing, installation, dimensions and weights

GOLD PX, counterflow heat exchanger, size 025/030

Delivery and transport within the site

The GOLD PX 025/030 can be supplied as two units, or in a number of different combinations of unit sections from the factory, see the section: Description of the Air Handling Unit. Filter/fan sections for PX and PX Top can be combined, see the section: Description of the Air Handling Unit.

The unit sections are jointed together/split by means of bolts. The electrical and control cables between the unit sections have quick-fit connectors.

The air handling unit/unit sections is/are delivered on wooden beams.

The electrical cabinet and the drain pipe on the front of the air handling unit can be removed, if required, for transporting the unit within the building site.

Duct connection options

- A:** Specify right-hand or left-hand version when ordering.
- B:** Specify whether the unit shall have an air intake from above for outdoor air and/or extract air when placing orders (does not apply to outdoor units).

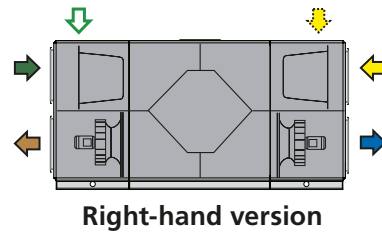

Right-hand version

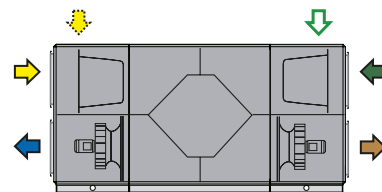

Left-hand version

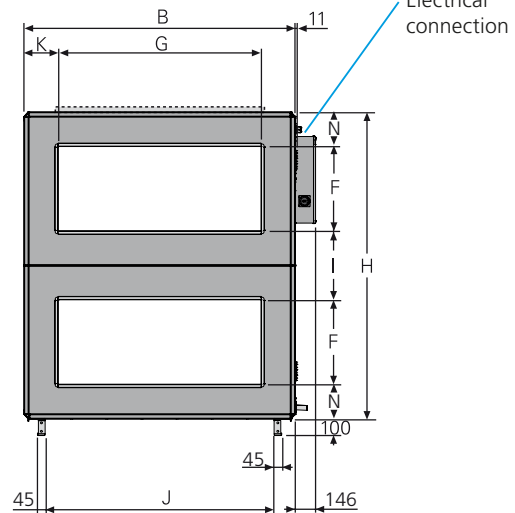
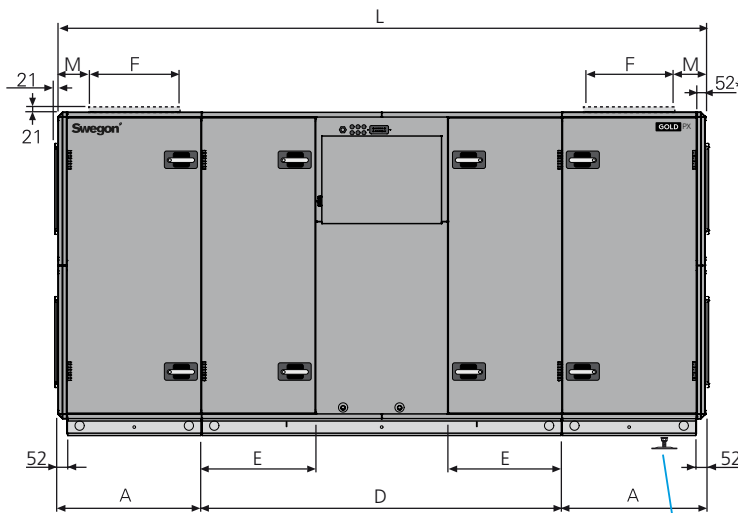
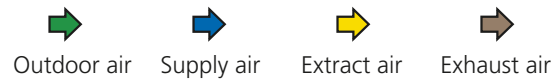

* The air handling unit is supplied without end connection panel if a duct accessory housed in an insulated casing will be connected. The AHU can also be supplied with full face end connection panel (accessory).

If a water trap (accessory) is fitted, the air handling unit must be raised at least 50 mm to provide space for the water trap. Support feet (accessories) can be used for this purpose.

Size	A	B	D	E	F	G	H	I	J	K	L	M	N	Weight, kg
025/030	847,5	1600	2130	675	500	1200	1811	405	1354	200	3825	200	203	1235-1451

Division into sections for transport

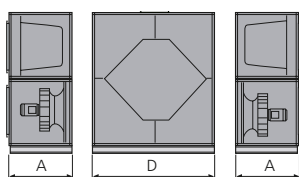

The unit can be divided into three sections at the building site.

Dimensions: See A and D in the table above.

Weight: A = 249-345 kg, D = 737-761 kg.

Clear space for inspection

A clear space of 900 mm should be provided in front of the unit.

Rated data per fan

- Size 025: Motor shaft power 2.4 kW alt. 3.4 kW, motor control system: 3 x 400 V, 50 Hz
- Size 030: Motor shaft power: 4.0 kW alt. 5.0 kW, motor control system: 3 x 400 V, 50 Hz

Electrical connection

See table Electrical data at the end of this section.

Sizing, installation, dimensions and weights

GOLD PX Top, counterflow heat exchanger, size 025/030

Delivery and transport within the site

The GOLD Top PX 025/030 can be supplied as two units, or in a number of different combinations of unit sections from the factory, see the section: Description of the Air Handling Unit. Filter/fan sections for PX and PX Top can be combined, see the section: Description of the Air Handling Unit.

The unit sections are jointed together/split by means of bolts. The electrical and control cables between the unit sections have quick-fit connectors.

The air handling unit/unit sections is/are delivered on wooden beams.

The electrical cabinet and the drain pipe on the front of the air handling unit can be removed, if required, for transporting the unit within the building site.

Duct connection options

A: All the duct connections are arranged from the top of the air handling unit (the unit must not be installed outdoors).

B: Specify right-hand or left-hand version when ordering.

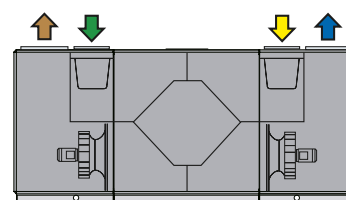

Right-hand version

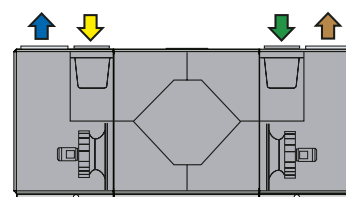

Left-hand version

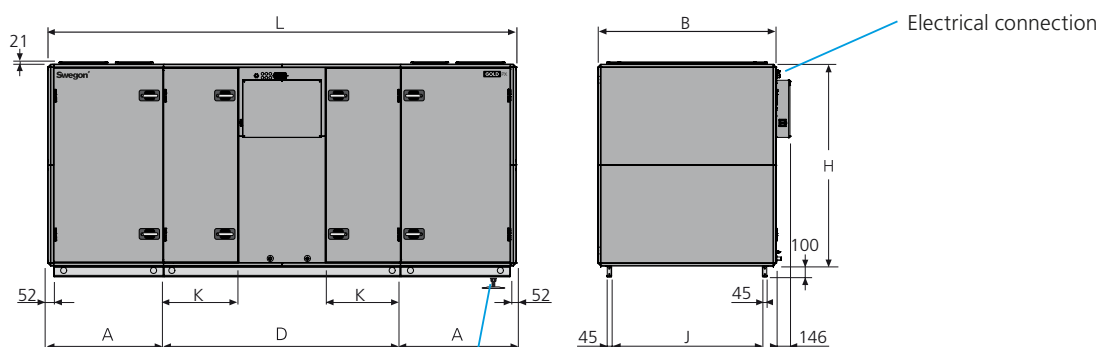
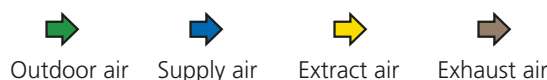

If a water trap (accessory) is fitted, the air handling unit must be raised at least 50 mm to provide space for the water trap. Support feet (accessories) can be used for this purpose.

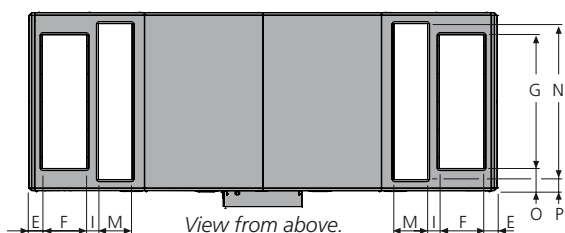

Size	A	B	D	E	F	G	H	I	J	K	L	M	N	O	P	Weight, kg
025/030	1039	1600	2130	120	400	1200	1811	106	1354	675	4208	300	1400	200	100	1375-1513

Division into sections for transport

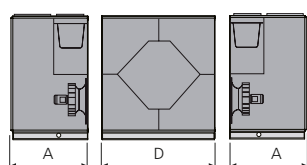

The unit can be divided into three sections at the building site.

Dimensions: See A and D in the table above.

Weight: A = 319-376 kg, D = 737-761 kg.

Clear space for inspection

A clear space of 1,000 mm should be provided in front of the unit.

Rated data per fan

Size 025: Motor shaft power 2.4 kW alt. 3.4 kW, motor control system: 3 x 400 V, 50 Hz

Size 030: Motor shaft power: 4.0 kW alt. 5.0 kW, motor control system: 3 x 400 V, 50 Hz

Electrical connection

See table Electrical data at the end of this section.

Sizing, installation, dimensions and weights

GOLD PX, counterflow heat exchanger, size 035/040
 Size 035 (Extract air fan size 040 can be selected, see the next page)

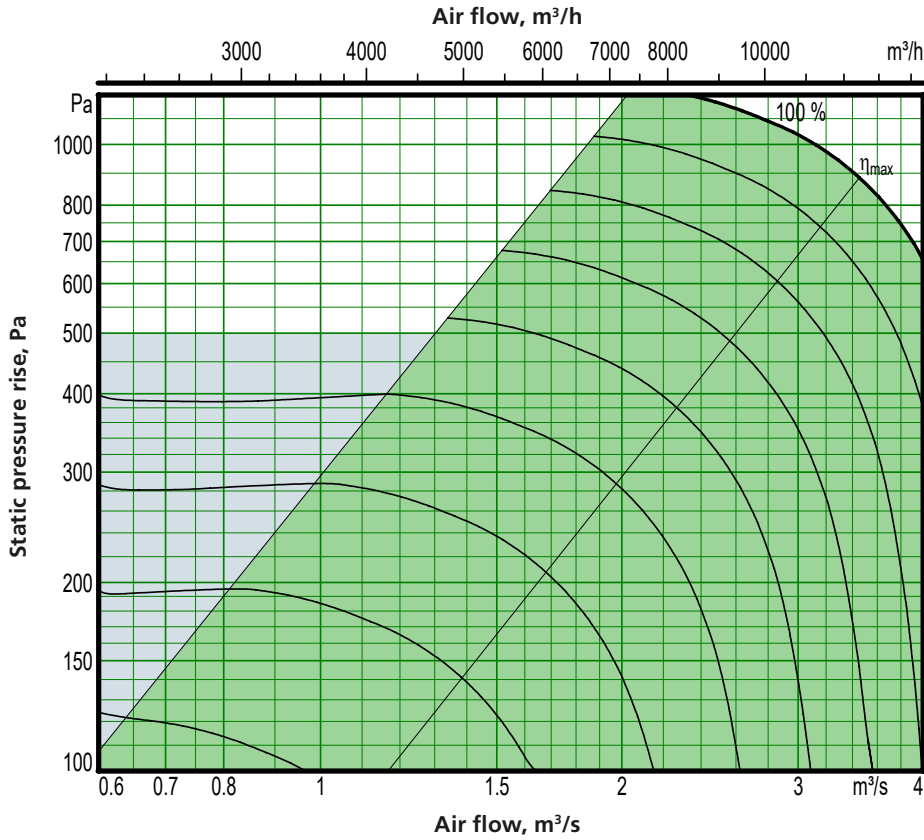

Motor shaft power: 5.0 kW (capacity variant 2)

- Recommended working range for sizing.
- If pressure regulation is used, the air flow can be regulated to zero.
- However this presupposes a certain static pressure drop in the ducting (approx. 50 Pa).

Min. and max. airflows

The flows specified refer to those that can be preset in the hand-held terminal. The practical flow limits are determined by the external pressure drop.

Size	Min. airflow (on airflow regulation)		Max. airflow	
	m³/h	m³/s	m³/h	m³/s
035	1800	0.50	14040	3.90

Exact sizing can be carried out in the AHU Design air handling unit selection program

Sizing, installation, dimensions and weights

GOLD PX, counterflow heat exchanger, size 035/040

Size 040 (Extract air fan size 035 can be selected, see the previous page)

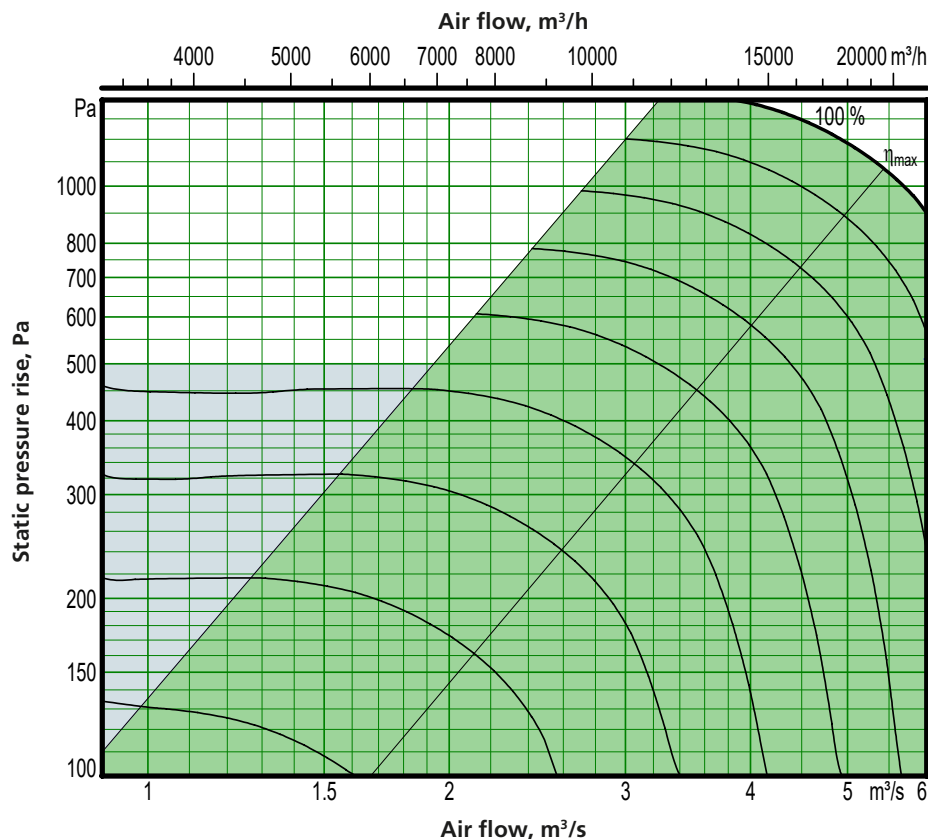

Motor shaft power: 10 kW (capacity variant 2)

- Recommended working range for sizing.
- If pressure regulation is used, the air flow can be regulated to zero.
- However this presupposes a certain static pressure drop in the ducting (approx. 50 Pa).

Min. and max. airflows

The flows specified refer to those that can be preset in the hand-held terminal. The practical flow limits are determined by the external pressure drop.

Size	Min. airflow (on airflow regulation)		Max. airflow	
	m ³ /h	m ³ /s	m ³ /h	m ³ /s
040	2700	0.75	18000	5.00

Exact sizing can be carried out in the AHU Design air handling unit selection program

Sizing, installation, dimensions and weights

GOLD PX, counterflow heat exchanger, size 035/040

Delivery and transport within the site

The GOLD PX 035/040 can be supplied as three units, or in a number of different combinations of unit sections from the factory, see the section: Description of the Air Handling Unit/ Delivery Configuration RX/PX/CX, sizes 011-080.

The unit sections are jointed together/split by means of bolts. The electrical and control cables between the unit sections have quick-fit connectors.

The air handling unit/unit sections is/are delivered on wooden beams.

The electrical cabinet and the drain pipe on the front of the air handling unit can be removed, if required, for transporting the unit within the building site.

Duct connection options

A: Specify right-hand or left-hand version when ordering.

B: Specify whether the unit shall have an air intake from above for outdoor air and/or extract air when placing orders (does not apply to outdoor units).

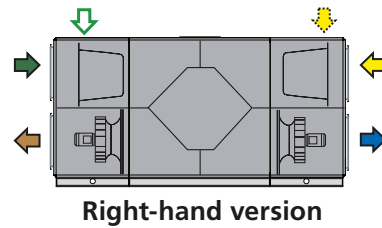

Right-hand version

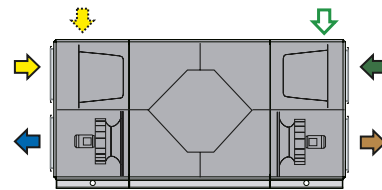

Left-hand version

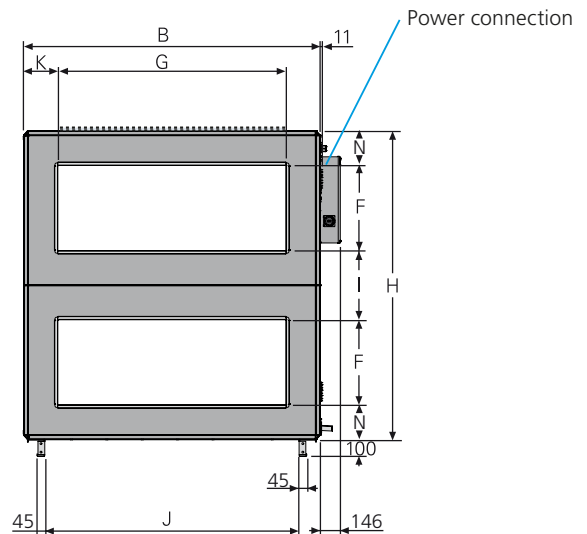
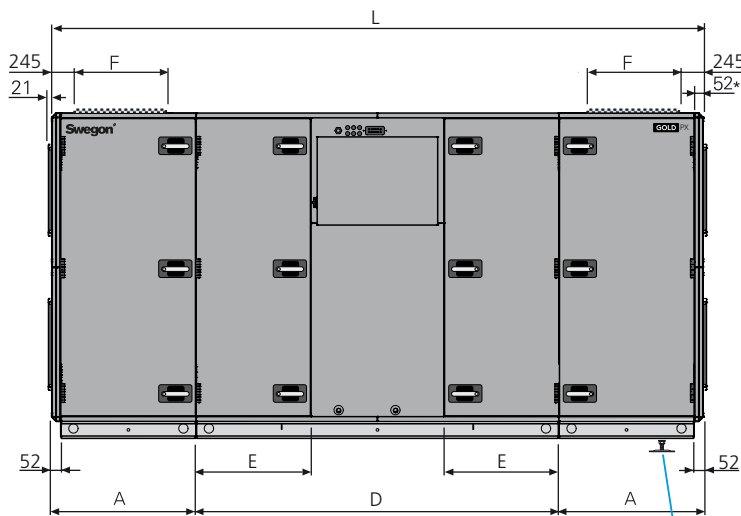

* The air handling unit is supplied without end connection panel if a duct accessory housed in an insulated casing will be connected. The AHU can also be supplied with full face end connection panel (accessory).

If a water trap (accessory) is fitted, the air handling unit must be raised at least 50 mm to provide space for the water trap. Support feet (accessories) can be used for this purpose.

Size	A	B	D	E	F	G	H	I	J	K	L	N	Weight, kg
035/040	1038.5	1990	2400	806	600	1400	2159	479	1744	295	4477	240	1792-2082

Division into sections for transport

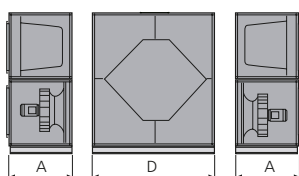

The unit can be divided into three sections at the building site.

Dimensions: See A and D in the table above.

Weight: A = 377-504 kg, D = 1038-1074 kg.

Clear space for inspection

A clear space of 1,100 mm should be provided in front of the unit.

Rated data per fan

Size 035: Motor shaft power: 4.0 kW alt. 5.0 kW, motor control system, 3 x 400 V, 50 Hz

Size 040: Motor shaft power: 6.5 kW alt. 10 kW, motor control system, 3 x 400 V, 50 Hz

Electrical connection

See table Electrical data at the end of this section.

Sizing, installation, dimensions and weights

GOLD CX, coil heat exchangers, size 035/040

Size 035 (Extract air fan size 040 can be selected, see the next page)

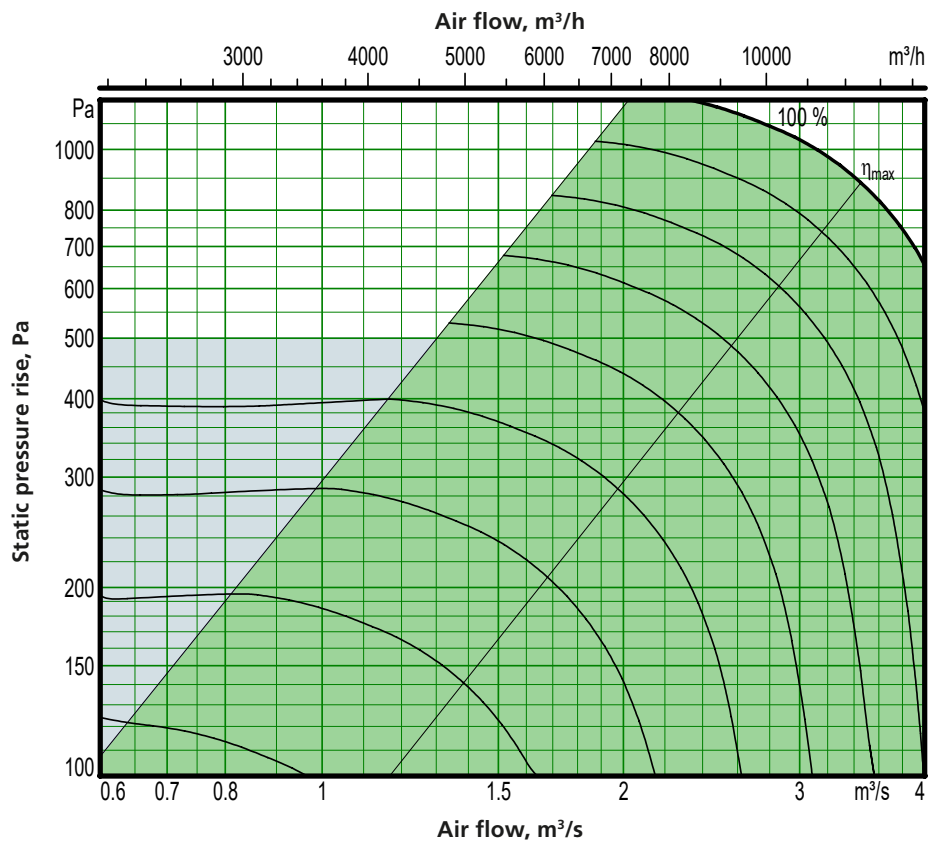

Motor shaft power: 5.0 kW (capacity variant 2)

- Recommended working range for sizing.
- If pressure regulation is used, the air flow can be regulated to zero.
- However this presupposes a certain static pressure drop in the ducting (approx. 50 Pa).

Min. and max. airflows

The flows specified refer to those that can be preset in the hand-held terminal. The practical flow limits are determined by the external pressure drop.

Size	Min. airflow (on airflow regulation)		Max. airflow	
	m³/h	m³/s	m³/h	m³/s
035	1800	0.50	14040	3.90

Exact sizing can be carried out in the AHU Design air handling unit selection program

Sizing, installation, dimensions and weights

GOLD CX, coil heat exchangers, size 035/040

Size 040 (Extract air fan size 035 can be selected, see the previous page)

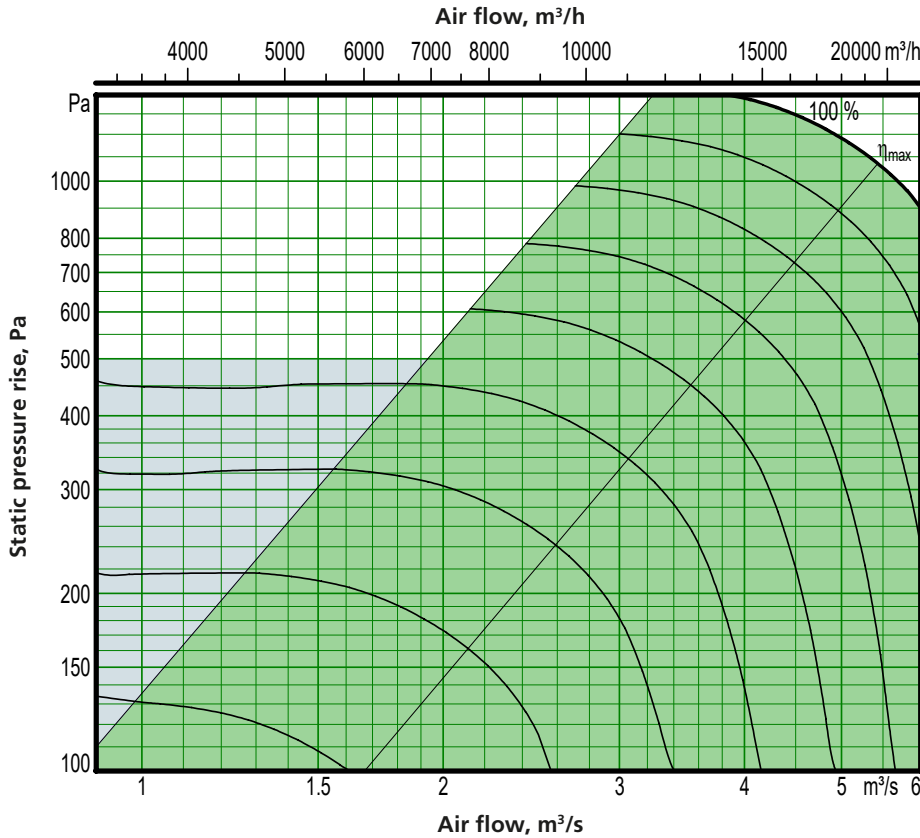

Motor shaft power: 10 kW (capacity variant 2)

- Recommended working range for sizing.
- If pressure regulation is used, the air flow can be regulated to zero.
- However this presupposes a certain static pressure drop in the ducting (approx. 50 Pa).

Min. and max. airflows

The flows specified refer to those that can be preset in the hand-held terminal. The practical flow limits are determined by the external pressure drop.

Size	Min. airflow (on airflow regulation)		Max. airflow	
	m³/h	m³/s	m³/h	m³/s
040	2700	0.75	18000	5.00

Exact sizing can be carried out in the AHU Design air handling unit selection program

Sizing, installation, dimensions and weights

GOLD CX, coil heat exchangers, size 035/040

Delivery and transport within the site

The GOLD CX 035/040 is supplied in three units, or in a number of different combinations of unit sections from the factory, see the section: Description of the Air Handling Unit/Delivery Configuration RX/PX/CX, sizes 011-080.

The unit sections are jointed together/split by means of bolts. The electrical and control cables between the unit sections have quick-fit connectors.

The air handling unit/unit sections is/are delivered on wooden beams.

The coil heat exchanger system is filled with liquid from the factory.

Duct connection options

A: Specify right-hand or left-hand version when ordering. If the air handling unit is supplied with all the end connection panels, the version can be changed at the building site using the hand-held terminal.

B: The arrangement of the functional sections can be vertically reversed. To be specified when placing an order, see the illustration to the right.

C: Specify upper fan outlet for upward air discharge when placing orders (not for outdoor units).

D: Specify whether the unit shall have an air intake from above for outdoor air or extract air when placing orders (Does not apply to units installed outdoors).

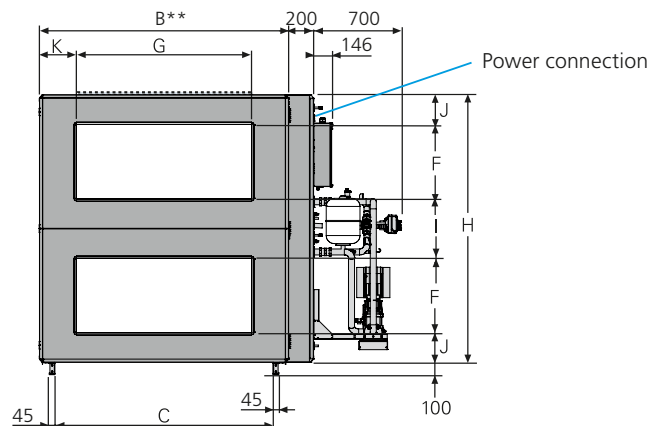
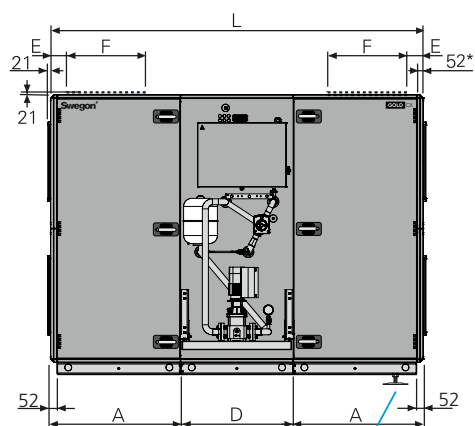
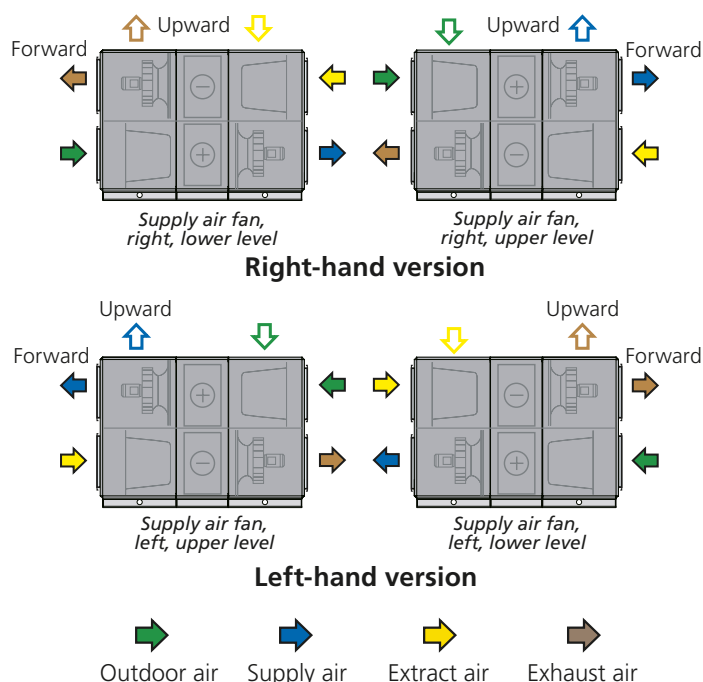

If a water trap (accessory) is fitted, the air handling unit must be raised at least 50 mm to provide space for the water trap. Support feet (accessories) can be used for this purpose. Applies to right-hand version with the supply air fan to the upper right and to left-hand version with the supply air fan to the upper left.

* The air handling unit is supplied without end connection panel if a duct accessory housed in an insulated casing will be connected.

The AHU can also be supplied with full face end connection panel (accessory).

** Width of centre section's casing = B + 200 mm.

Size	A	B	C	D	E	F	G	H	I	J	K	L	Weight, kg
035/040	1038.5	1990	1744	900	245	600	1400	2159	479	240	295	2977	1934-2188

Division into sections for transport

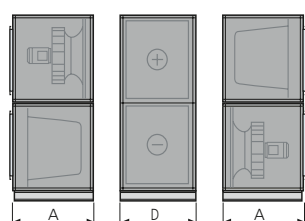

The unit can be divided into three sections at the building site.

Dimensions: See A and D in the table above.

Weight: A = 377-504 kg, D = 1,180 kg.

Clear space for inspection

A clear space of 1,100 mm should be provided in front of the unit.

Rated data per fan

Size 035: Motor shaft power: 4.0 kW alt. 5.0 kW, motor control system, 3 x 400 V, 50 Hz

Size 040: Motor shaft power: 6.5 kW alt. 10 kW, motor control system: 3 x 400 V, 50 Hz

Electrical connection

See table Electrical data at the end of this section.

Sizing, installation, dimensions and weights

GOLD CX, coil heat exchangers, size 050/060

Size 050 (Extract air fan size 060 can be selected, see the next page)

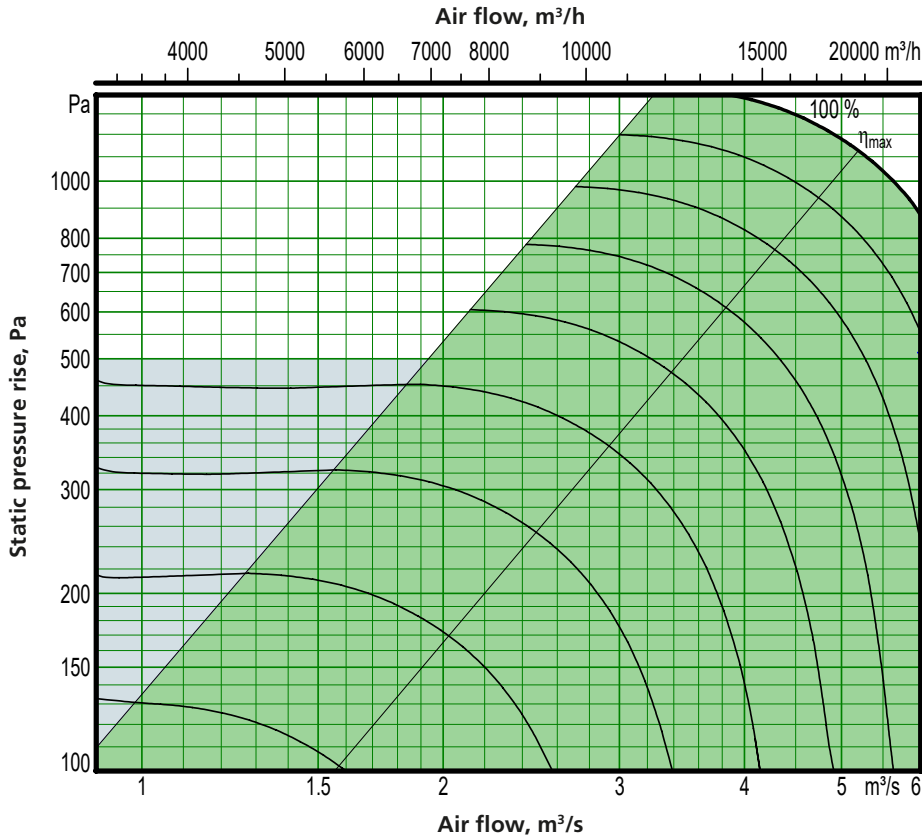

Motor shaft power: 10 kW (capacity variant 2)

- Recommended working range for sizing.
- If pressure regulation is used, the air flow can be regulated to zero.
- However this presupposes a certain static pressure drop in the ducting (approx. 50 Pa).

Min. and max. airflows

The flows specified refer to those that can be preset in the hand-held terminal. The practical flow limits are determined by the external pressure drop.

Size	Min. airflow (on airflow regulation)		Max. airflow	
	m³/h	m³/s	m³/h	m³/s
050	2700	0.75	18000	5.00

Exact sizing can be carried out in the AHU Design air handling unit selection program

Sizing, installation, dimensions and weights

GOLD CX, coil heat exchanger, size 050/060

Size 060 (Extract air fan size 050 can be selected, see the previous page)

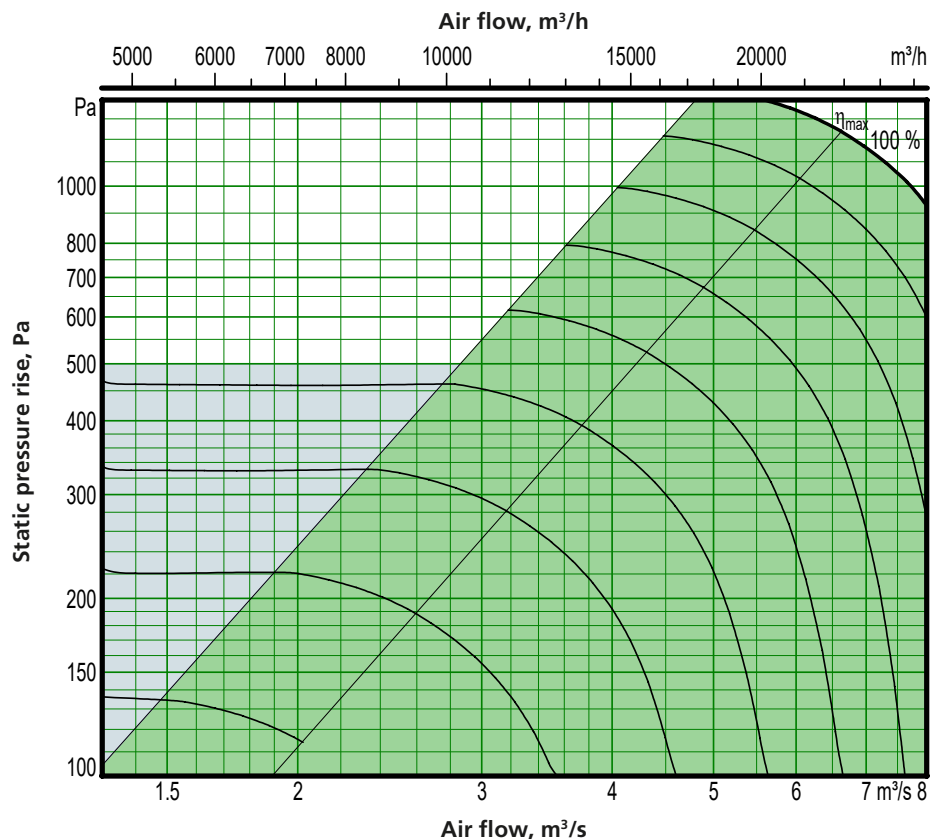

Motor shaft power: 2 x 6.5 kW (capacity variant 2)

- Recommended working range for sizing.
- If pressure regulation is used, the air flow can be regulated to zero.
- However this presupposes a certain static pressure drop in the ducting (approx. 50 Pa).

Min. and max. airflows

The flows specified refer to those that can be preset in the hand-held terminal. The practical flow limits are determined by the external pressure drop.

Size	Min. airflow (on airflow regulation)		Max. airflow	
	m³/h	m³/s	m³/h	m³/s
060	3600	1.00	23400	6.50

Exact sizing can be carried out in the AHU Design air handling unit selection program

Sizing, installation, dimensions and weights

GOLD CX, coil heat exchangers, size 050/060

Delivery and transport within the site

The GOLD CX 050/060 is supplied in three units, or in a number of different combinations of unit sections from the factory, see the section: Description of the Air Handling Unit/Delivery Configuration RX/PX/CX, sizes 011-080.

The unit sections are jointed together/split by means of bolts. The electrical and control cables between the unit sections have quick-fit connectors

The air handling unit/unit sections is/are delivered on wooden beams.

The coil heat exchanger system is filled with liquid from the factory.

Duct connection options

- A:** Specify right-hand or left-hand version when ordering.
- B:** The arrangement of the functional sections can be vertically reversed. To be specified when placing an order, see the illustration to the right.
- C:** Specify upper fan outlet for upward air discharge when placing orders (not for outdoor units).
- D:** Specify whether the unit shall have an air intake from above for outdoor air or extract air when placing orders (Does not apply to units installed outdoors). N.B.! Duct connection size: 2,000 x 600 mm.

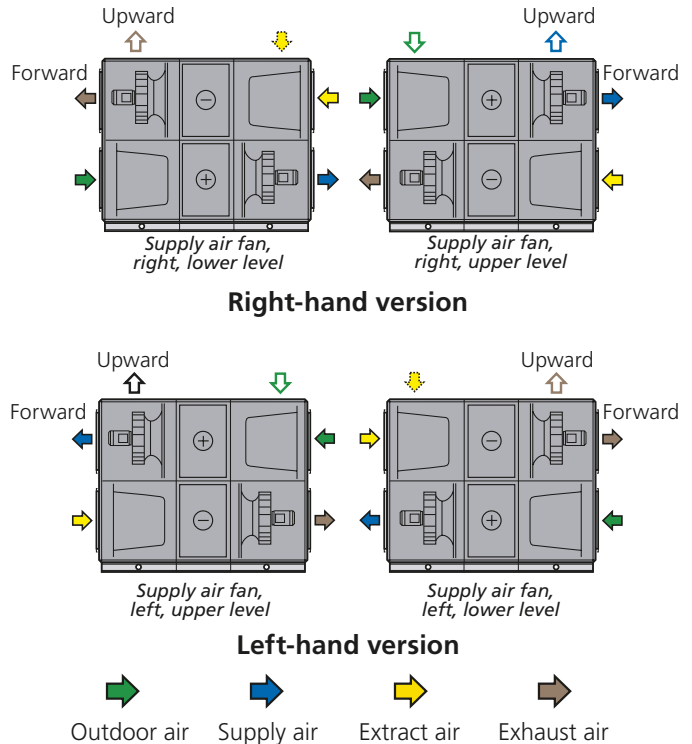

* If the duct accessory is housed in an insulated casing, the AHU is supplied without the end connection panel. The AHU can also be supplied with full face end connection panel (accessory).

** Width of centre section's casing = B + 200 mm.

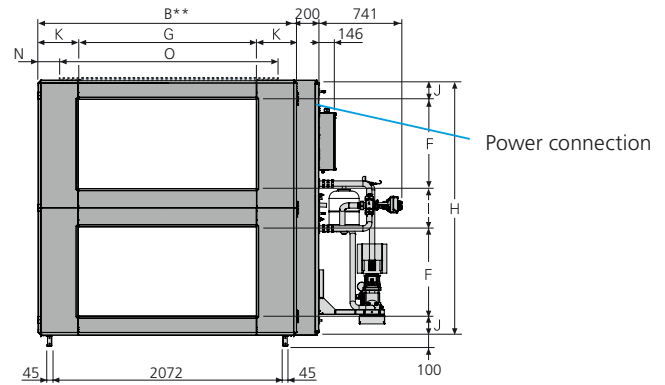
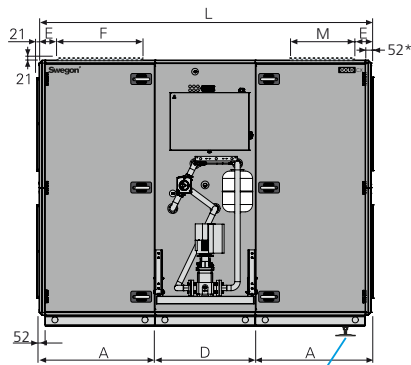

If a water trap (accessory) is fitted, the air handling unit must be raised at least 50 mm to provide space for the water trap. Adjustable support feet (accessories) can be appropriately fitted to the base beams for this purpose. Applies to right-hand version with the supply air fan to the upper right and to left-hand version with the supply air fan to the upper left.

Size	A	B	D	E	F	G	H	I	J	K	L	M	N	O	Weight, kg
050/060	1038,5	2318	900	145	800	1600	2288	344	172	359	2977	600	159	2000	2346-2718

Division into sections for transport

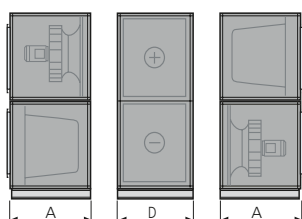

The unit can be divided into three sections at the building site.

Dimensions: See A and D in the table above.

Weight: A = 444-630 kg, D = 1458 kg.

Clear space for inspection

A clear space of 1,100 mm should be provided in front of the unit.

Rated data per fan

- Size 050: Motor shaft power: 6.5 kW alt. 10 kW, motor control system: 3 x 400 V, 50 Hz
- Size 060: Motor shaft power: 2 x 4.0 kW alt. 2 x 6.5 kW, motor control system: 3 x 400 V, 50 Hz

Electrical connection

See table Electrical data at the end of this section.

Sizing, installation, dimensions and weights

GOLD CX, coil heat exchangers, size 070/080

Size 070 (Extract air fan size 080 can be selected, see the next page)

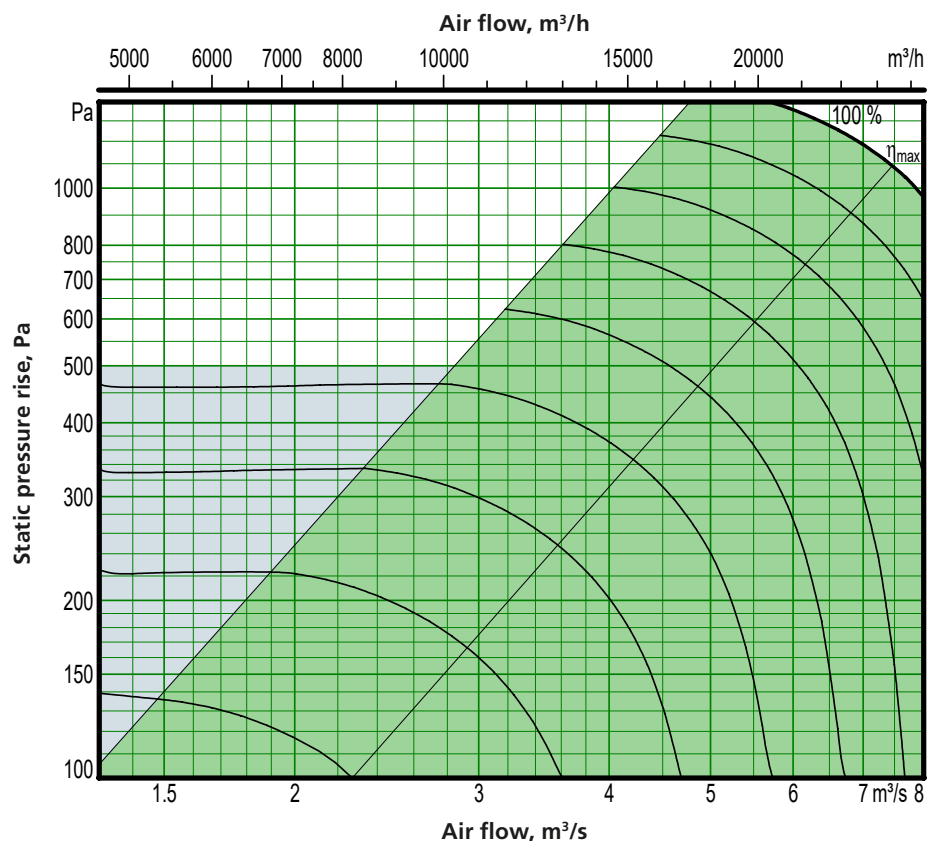

Motor shaft power: 2 x 6.5 kW (capacity variant 2)

- Recommended working range for sizing.
- If pressure regulation is used, the air flow can be regulated to zero.
- However this presupposes a certain static pressure drop in the ducting (approx. 50 Pa).

Min. and max. airflows

The flows specified refer to those that can be preset in the hand-held terminal. The practical flow limits are determined by the external pressure drop.

Size	Min. airflow (on airflow regulation)		Max. airflow	
	m³/h	m³/s	m³/h	m³/s
070	3600	1.00	27000	7.50

Exact sizing can be carried out in the AHU Design air handling unit selection program

Sizing, installation, dimensions and weights

GOLD CX, coil heat exchangers, size 070/080

Size 080 (Extract air fan size 070 can be selected, see the previous page)

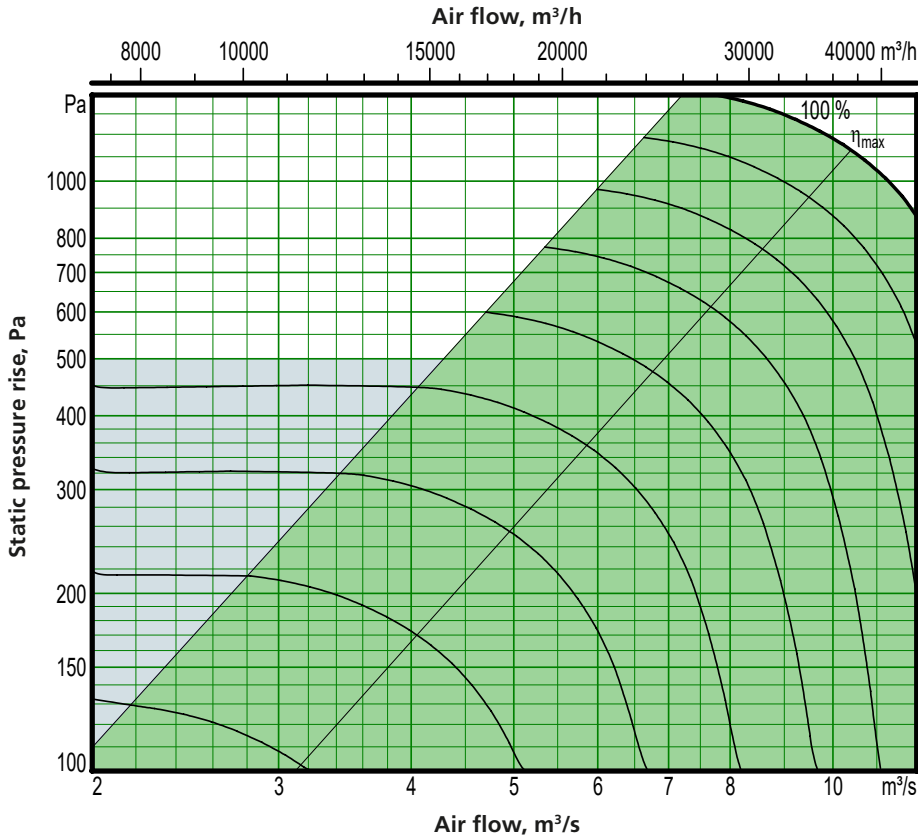

Motor shaft power: 2 x 10 kW (capacity variant 2)

- Recommended working range for sizing.
- If pressure regulation is used, the air flow can be regulated to zero.
- However this presupposes a certain static pressure drop in the ducting (approx. 50 Pa).

Min. and max. airflows

The flows specified refer to those that can be preset in the hand-held terminal. The practical flow limits are determined by the external pressure drop.

Size	Min. airflow (on airflow regulation)		Max. airflow	
	m³/h	m³/s	m³/h	m³/s
080	5400	1.50	34200	9.50

Exact sizing can be carried out in the AHU Design air handling unit selection program

Sizing, installation, dimensions and weights

GOLD CX, coil heat exchangers, size 070/080

Delivery and transport within the site

The GOLD CX 070/080 is supplied in three units, or in a number of different combinations of unit sections from the factory, see the section: Description of the Air Handling Unit/Delivery Configuration RX/PX/CX, sizes 011-080.

The unit sections are joined together/split by means of bolts. The electrical and control cables between the unit sections have quick-fit connectors.

The coil heat exchanger system is filled with liquid from the factory.

Duct connection options

A: Specify right-hand or left-hand version when ordering.

B: The arrangement of the functional sections can be vertically reversed. To be specified when placing an order, see the illustration to the right.

C: Specify upper fan outlet for upward air discharge when placing orders (not for outdoor units).

D: Specify whether the unit shall have an air intake from above for outdoor air or extract air when placing orders (Does not apply to units installed outdoors). N.B.! Duct connection size: 2,400 x 750 mm.

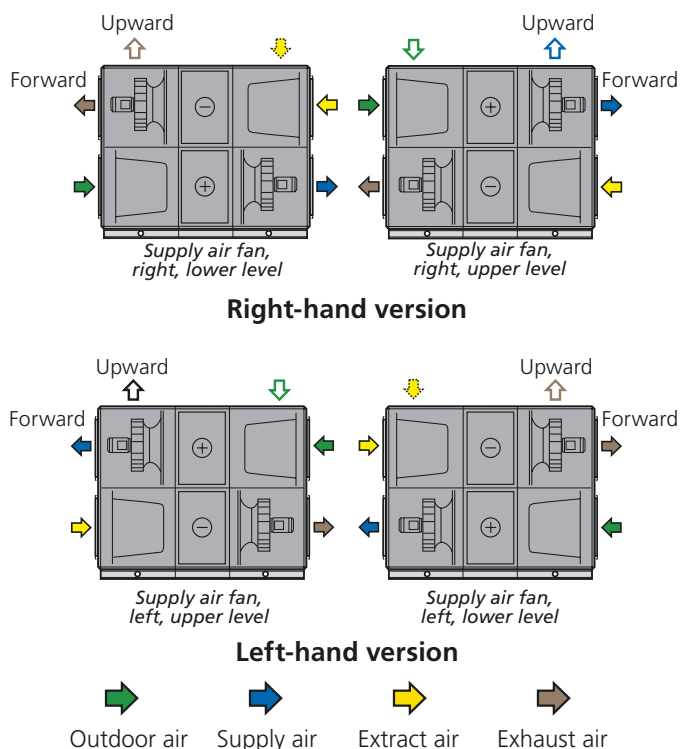

* If the duct accessory is housed in an insulated casing, the AHU is supplied without the end connection panel. The AHU can also be supplied with full face end connection panel (accessory).

** Width of centre section's casing = B + 200 mm.

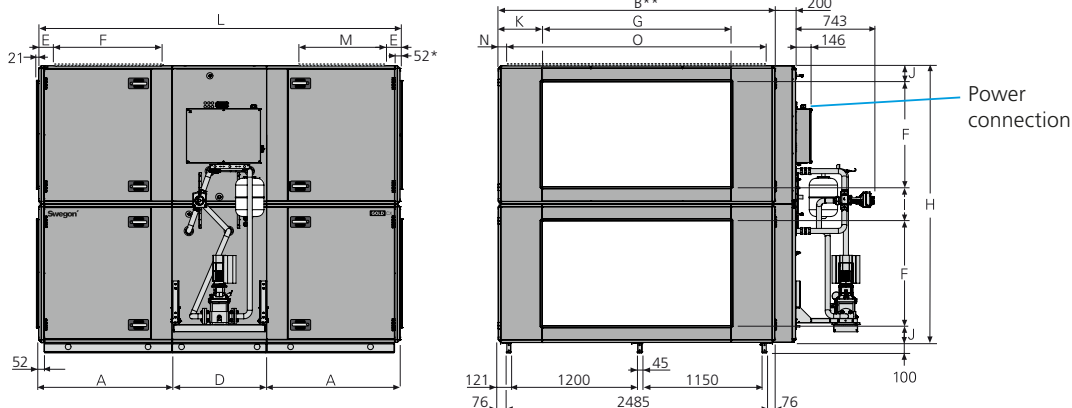

If a water trap (accessory) is fitted, the air handling unit must be raised at least 50 mm to provide space for the water trap. Adjustable support feet (accessories) can be appropriately fitted to the base beams for this purpose. Applies to right-hand version with the supply air fan to the upper right and to left-hand version with the supply air fan to the upper left.

Size	A	B	D	E	F	G	H	I	J	K	L	M	N	O	Weight, kg
070/080	1273,5	2637	900	162	1000	1800	2640	320	160	418,5	3447	750	118,5	2400	3454-3794

Division into sections for transport

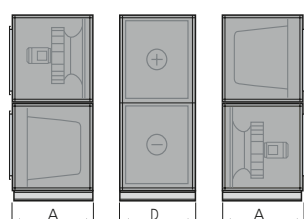

The unit can be divided into three sections at the building site.

Dimensions: See A and D in the table above.

Weight: A = 786-956 kg, D = 1882 kg.

Clear space for inspection

A clear space of 1,100 mm should be provided in front of the unit.

Rated data per fan

Size 070: Motor shaft power: 2 x 4.0 kW alt. 2 x 6.5 kW, motor control system: 3 x 400 V, 50 Hz

Size 080: Motor shaft power: 2 x 6.5 kW alt. 2 x 10 kW, motor control system: 3 x 400 V, 50 Hz

Electrical connection

See table Electrical data at the end of this section.

Sizing, installation, dimensions and weights

GOLD CX, coil heat exchangers, size 100

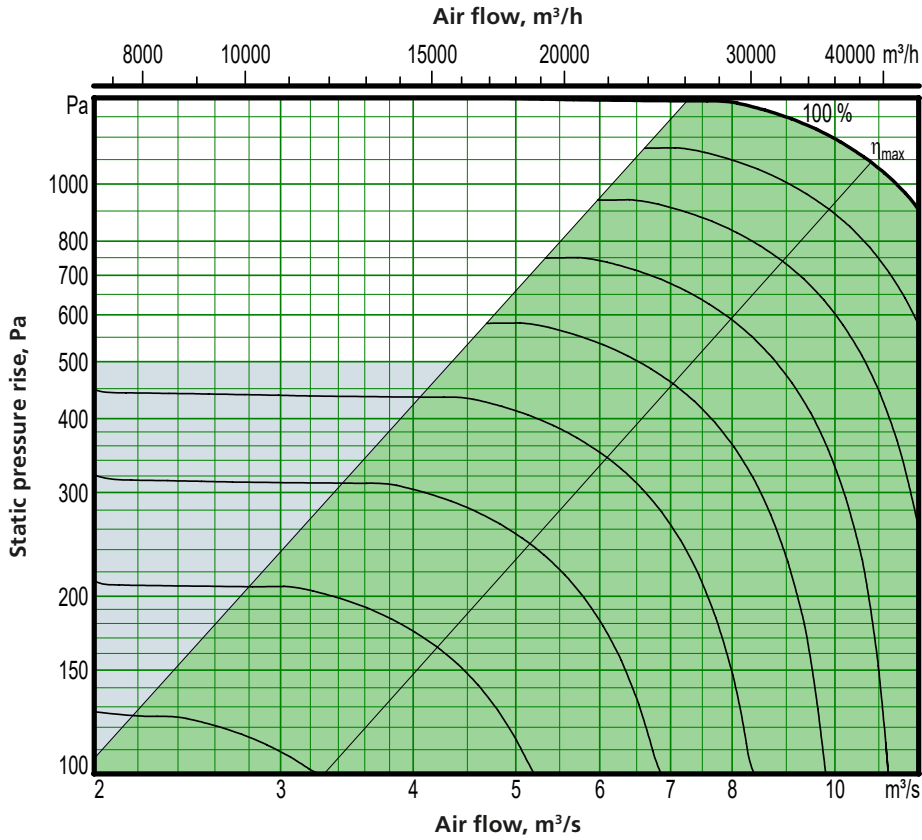

Motor shaft power: 2 x 10 kW (capacity variant 2)

- Recommended working range for sizing.
- If pressure regulation is used, the air flow can be regulated to zero.
- However this presupposes a certain static pressure drop in the ducting (approx. 50 Pa).

Min. and max. air flows

The flows specified refer to those that can be preset in the hand-held terminal. The practical flow limits are determined by the external pressure drop.

Size	Min. airflow (on airflow regulation)		Max. airflow	
	m³/h	m³/s	m³/h	m³/s
100	5400	1.50	39600	11.0

Exact sizing can be carried out in the AHU Design air handling unit selection program

Sizing, installation, dimensions and weights

GOLD CX, coil heat exchangers, size 100

Delivery and transport within the site

The GOLD CX 100 is supplied as six separate sections: Two fan sections, two filter sections and two coil heat exchanger sections. The six sections must be fitted together at the building site. The pipework package including the control box can be ordered as accessories and are supplied in unassembled condition for floor or wall mounting (see TBXZ pipework package under Accessories).

The three sections are to be jointed together by bolts and the electrical and control cables are simple to connect.

Duct connection options

- A:** Specify right-hand or left-hand version when ordering.
- B:** The arrangement of the functional sections can vary. Specify this by selecting fan arrangement 1, 2, 4 or 5 when placing orders. For fan arrangement 4 and 5, you should also specify: supply air in upper or lower level.
- C:** Specify upper fan outlet for upward air discharge when placing orders (not for outdoor units). N.B.! Duct connection size: 2,500 x 800 mm.

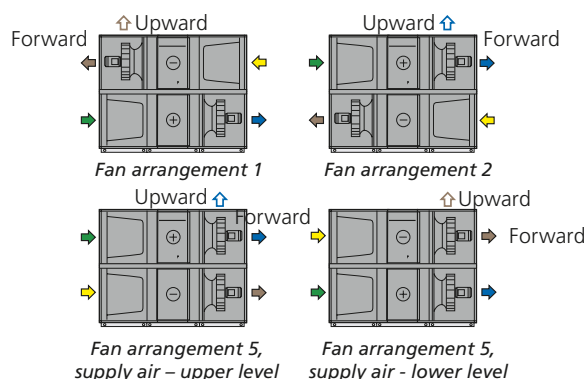

Right-hand version

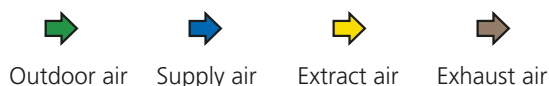
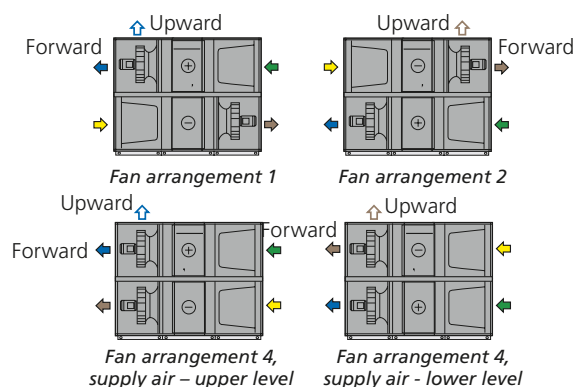

Left-hand version

* If the duct accessory is housed in an insulated casing, the AHU is supplied without the end connection panel. The AHU can also be supplied with full face end connection panel (accessory).

** Width of centre section's casing = B + 200 mm.

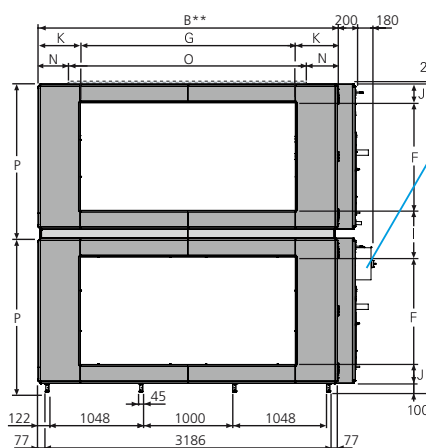
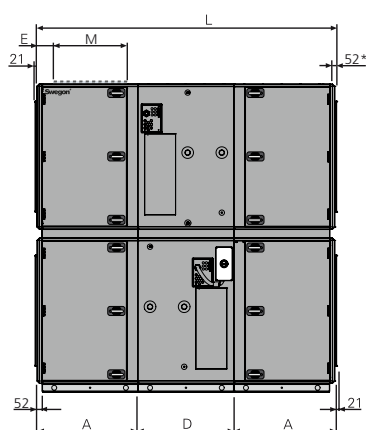

Power connection
 If extract air flows through the lower level: The air handling unit must be raised at least 50 mm (Higher than the upper edge of the base beams) to provide space for the water trap.

Size	A	B	D	E	F	G	H	I	J	K	L	M	N	O	P	Weight, kg
100	1122	3340	1070	187	1200	2400	3440	520	210	470	3314	800	420	2500	1720	4294-4772

Transport, dimensions and weights

Filter and fan sections

See dimensions A and P in the table above.
 Weight: fan section = 644-720 kg, filter section = 402-540 kg.

Heat exchanger sections

See dimensions D and P in the table above.
 Weight: Heat exchanger section = 1101-1126 kg.

Clear space for inspection

A clear space of 1,000 mm should be provided in front of the unit.

Rated data per fan

Motor shaft power: 2 x 6.5 kW alt. 2 x 10 kW,
 motor control system: 3 x 400 V, 50 Hz

Electrical connection

See table Electrical data at the end of this section.

Sizing, installation, dimensions and weights

GOLD CX, coil heat exchangers, size 120

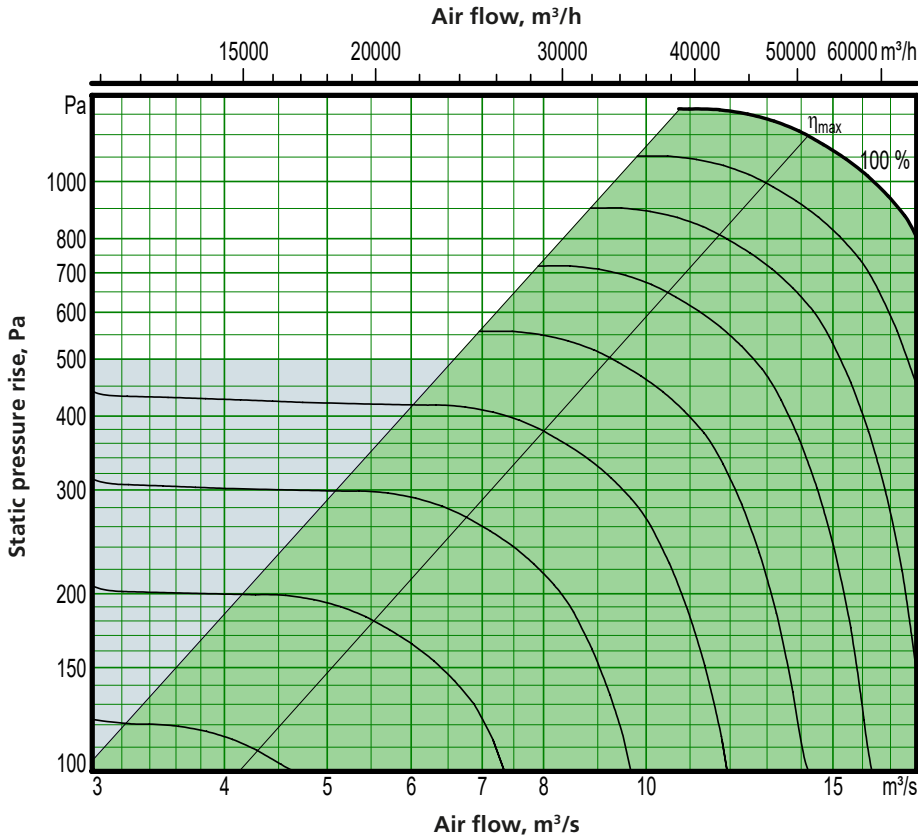

Motor shaft power: 3 x 10 kW (capacity variant 2)

- Recommended working range for sizing.
- If pressure regulation is used, the air flow can be regulated to zero.
- However this presupposes a certain static pressure drop in the ducting (approx. 50 Pa).

Min. and max. air flows

The flows specified refer to those that can be preset in the hand-held terminal. The practical flow limits are determined by the external pressure drop.

Size	Min. airflow (on airflow regulation)		Max. airflow	
	m³/h	m³/s	m³/h	m³/s
120	9000	2.50	50400	14.0

Exact sizing can be carried out in the AHU Design air handling unit selection program

Sizing, installation, dimensions and weights

GOLD CX, coil heat exchangers, size 120

Delivery and transport within the site

The GOLD CX 120 is supplied as six separate sections: Two fan sections, two filter sections and two coil heat exchanger sections. The six sections must be fitted together at the building site. The pipework package including the control box can be ordered as accessories and are supplied in unassembled condition for floor or wall mounting (see TBXZ pipework package under Accessories).

The three sections are to be jointed together by bolts and the electrical and control cables are simple to connect.

Duct connection options

A: Specify right-hand or left-hand version when ordering.

B: The arrangement of the functional sections can vary. Specify this by selecting fan arrangement 1, 2, 4 or 5 when placing orders. For fan arrangement 4 and 5, you should also specify: supply air in upper or lower level.

C: Specify upper fan outlet for upward air discharge when placing orders (not for outdoor units). N.B.! Duct connection size: 2,500 x 800 mm.

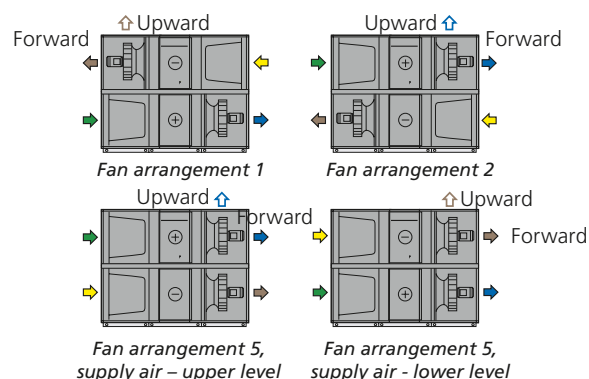
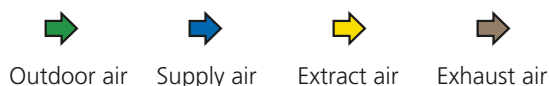

Right-hand version

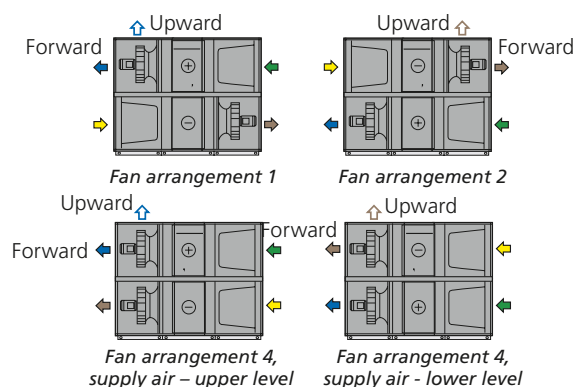

Left-hand version

* If the duct accessory is housed in an insulated casing, the AHU is supplied without the end connection panel. The AHU can also be supplied with full face end connection panel (accessory).

** Width of centre section's casing = B + 200 mm.

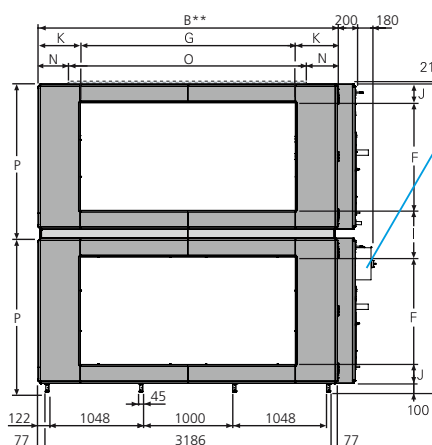
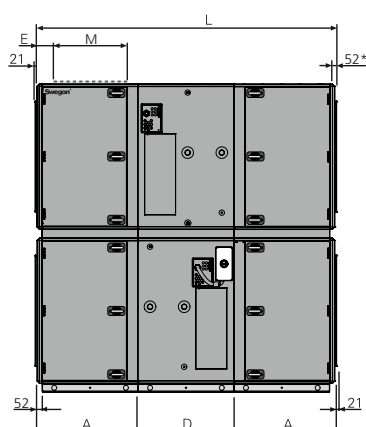

Power connection

If extract air flows through the lower level: The air handling unit must be raised at least 50 mm (Higher than the upper edge of the base beams) to provide space for the water trap.

Size	A	B	D	E	F	G	H	I	J	K	L	M	N	O	P	Weight, kg
120	1122	3340	1070	187	1200	2400	3440	520	210	470	3314	800	420	2500	1720	4494-4990

Transport, dimensions and weights

Filter and fan sections

See dimensions A and P in the table above.

Weight: fan section = 744-829 kg, filter section = 402-540 kg.

Heat exchanger sections

See dimensions D and P in the table above.

Weight: Heat exchanger section = 1101-1126 kg.

Clear space for inspection

A clear space of 1,000 mm should be provided in front of the unit.

Rated data per fan

Motor shaft power: 3 x 6.5 kW or 3 x 10 kW, motor control system: 3 x 400 V, 50 Hz

Electrical connection

See table Electrical data at the end of this section.

Sizing, installation, dimensions and weights

GOLD PX, counterflow heat exchanger, size 014 - 040

Electrical data

Shows the fuse size for different combinations of fan sizes and capacity variants. Fan A or B can be a supply air fan or an extract air fan or vice versa. It is the combination of fan A and B that determines the fuse size.

Electrical connection is 3-phase, 5-wire, 400 V -10/+15%, 50 Hz.

GOLD PX, size	Fan A, size/capacity variant	Fan B, size/capacity variant	Fuse protection (A)
014/020	014-1 (1,6 kW)	014-1 (1,6 kW)	10
	014-1 (1,6 kW)	014-2 (2,4 kW)	10
	014-1 (1,6 kW)	020-1 (2,4 kW)	10
	014-1 (1,6 kW)	020-2 (3,4 kW)	10
	014-2 (2,4 kW)	014-2 (2,4 kW)	10
	014-2 (2,4 kW)	020-1 (2,4 kW)	10
	014-2 (2,4 kW)	020-2 (3,4 kW)	16
	020-1 (2,4 kW)	020-1 (2,4 kW)	10
	020-1 (2,4 kW)	020-2 (3,4 kW)	10
	020-2 (3,4 kW)	020-2 (3,4 kW)	16
025/030	025-1 (2,4 kW)	025-1 (2,4 kW)	10
	025-1 (2,4 kW)	025-2 (3,4 kW)	16
	025-1 (2,4 kW)	030-1 (4,0 kW)	16
	025-1 (2,4 kW)	030-2 (5,0 kW)	16
	025-2 (3,4 kW)	025-2 (3,4 kW)	16
	025-2 (3,4 kW)	030-1 (4,0 kW)	16
	025-2 (3,4 kW)	030-2 (5,0 kW)	16
	030-1 (4,0 kW)	030-1 (4,0 kW)	16
	030-1 (4,0 kW)	030-2 (5,0 kW)	20
	030-2 (5,0 kW)	030-2 (5,0 kW)	20
035/040	35-1 (4,0 kW)	35-1 (4,0 kW)	16
	35-1 (4,0 kW)	35-2 (5,0 kW)	20
	35-1 (4,0 kW)	40-1 (6,5 kW)	20
	35-1 (4,0 kW)	40-2 (10 kW)	25
	35-2 (5,0 kW)	35-2 (5,0 kW)	20
	35-2 (5,0 kW)	40-1 (6,5 kW)	25
	35-2 (5,0 kW)	40-2 (10 kW)	25
	40-1 (6,5 kW)	40-1 (6,5 kW)	25
	40-1 (6,5 kW)	40-2 (10 kW)	32
	40-2 (10 kW)	40-2 (10 kW)	40

Sizing, installation, dimensions and weights

GOLD CX, counterflow heat exchanger, size 035 - 120

Electrical data

Shows the fuse size for different combinations of fan sizes and capacity variants. Fan A or B can be a supply air fan or an extract air fan or vice versa. It is the combination of fan A and B that determines the fuse size.

Electrical connection is 3-phase, 5-wire, 400 V -10/+15%, 50 Hz.

GOLD CX, size	Fan A, size/capacity variant	Fan B, size/capacity variant	Fuse protection (A)
035/040	35-1 (4,0 kW)	35-1 (4,0 kW)	20
	35-1 (4,0 kW)	35-2 (5,0 kW)	25
	35-1 (4,0 kW)	40-1 (6,5 kW)	25
	35-1 (4,0 kW)	40-2 (10 kW)	32
	35-2 (5,0 kW)	35-2 (5,0 kW)	25
	35-2 (5,0 kW)	40-1 (6,5 kW)	25
	35-2 (5,0 kW)	40-2 (10 kW)	32
	40-1 (6,5 kW)	40-1 (6,5 kW)	32
	40-1 (6,5 kW)	40-2 (10 kW)	32
	40-2 (10 kW)	40-2 (10 kW)	40
050/060	50-1 (6,5 kW)	50-1 (6,5 kW)	32
	50-1 (6,5 kW)	50-2 (10 kW)	40
	50-1 (6,5 kW)	60-1 (2 x 4,0 kW)	40
	50-1 (6,5 kW)	60-2 (2 x 6,5 kW)	40
	50-2 (10 kW)	50-2 (10 kW)	40
	50-2 (10 kW)	60-1 (2 x 4,0 kW)	40
	50-2 (10 kW)	60-2 (2 x 6,5 kW)	50
	60-1 (2 x 4,0 kW)	60-1 (2 x 4,0 kW)	40
	60-1 (2 x 4,0 kW)	60-2 (2 x 6,5 kW)	50
	60-2 (2 x 6,5 kW)	60-2 (2 x 6,5 kW)	63
070/080	70-1 (2 x 4,0 kW)	70-1 (2 x 4,0 kW)	40
	70-1 (2 x 4,0 kW)	70-2 (2 x 6,5 kW)	50
	70-1 (2 x 4,0 kW)	80-1 (2 x 6,5 kW)	50
	70-1 (2 x 4,0 kW)	80-2 (2 x 10 kW)	63
	70-2 (2 x 6,5 kW)	70-2 (2 x 6,5 kW)	63
	70-2 (2 x 6,5 kW)	80-1 (2 x 6,5 kW)	63
	70-2 (2 x 6,5 kW)	80-2 (2 x 10 kW)	63
	80-1 (2 x 6,5 kW)	80-1 (2 x 6,5 kW)	63
	80-1 (2 x 6,5 kW)	80-2 (2 x 10 kW)	80
	80-2 (2 x 10 kW)	80-2 (2 x 10 kW)	80
100	100-1 (2 x 6,5 kW)	100-1 (2 x 6,5 kW)	50
	100-1 (2 x 6,5 kW)	100-2 (2 x 10 kW)	63
	100-2 (2 x 10 kW)	100-2 (2 x 10 kW)	80
120	120-1 (3 x 6,5 kW)	120-1 (3 x 6,5 kW)	80
	120-1 (3 x 6,5 kW)	120-2 (3 x 10 kW)	100
	120-2 (3 x 10 kW)	120-2 (3 x 10 kW)	125

