

INSTALLATION, SERVICE AND USER MANUAL

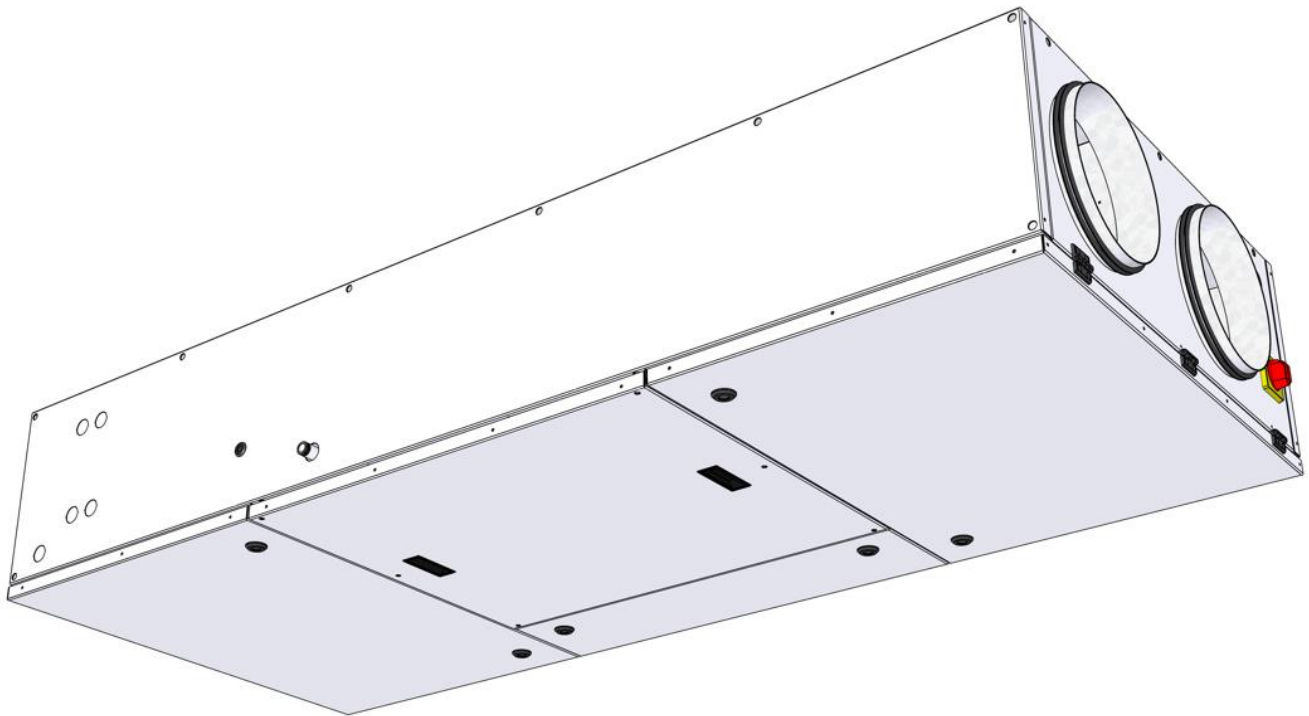

Applicable to manufacturing Nr 240000 →

VIII INSTALLATION page 16

X ELECTRICAL CONNECTION OF EXTERNAL DEVICES page 31

XIV STARTING UP page 45

XVI TROUBLESHOOTING - MAINTENANCE page 51

I.	TECHNICAL SPECIFICATIONS	5
I.1.	Electrical performance data	5
I.2.	Weights and dimensional data	5
II.	GENERAL.....	7
III.	UPON RECEIPT OF THE MATERIAL	9
III.1.	Quality check	9
III.2.	Unpacking.....	9
III.3.	Storage.....	9
IV.	END OF SERVICE LIFE.....	9
V.	PACKAGING AND PACKAGES.....	9
VI.	IDENTIFICATION AND LABELLING.....	10
VII.	OVERVIEW AND CONSTRUCTION	12
VII.1.	General overview of the unit.....	12
VII.2.	Sliding electric board	14
VII.3.	Control terminals and user connections	15
VIII.	INSTALLATION	16
VIII.1.	Handling.....	16
VIII.2.	Permitted installation configurations and precautions to be taken	17
VIII.3.	Horizontal lifting.....	17
VIII.3.a.	Fixing the frame to the ceiling	18
VIII.3.b.	Positioning the unit on the fixing frame	19
VIII.3.c.	Installation of the unit offset from the ceiling.....	21
VIII.4.	Access inside the unit.....	22
VIII.5.	Access to the sliding electric board and user touch control	23
VIII.6.	Connection of the supply pressure tap (LOBBY)	24
VIII.7.	Installation of filters clogging manometer	24
VIII.8.	Connection to the air network	26
VIII.9.	Motorised shutoff dampers (optional).....	26
VIII.10.	Connection of power supply	27
IX.	CONDENSATE EVACUATION	28
IX.1.	Evacuation by gravity - general	28
IX.2.	Plates heat exchanger siphon.....	28
IX.3.	Remote coil siphon	29
IX.4.	CO or DXR Coils condensate siphon	29
IX.4.a.	FLATPOWER 600...900.....	29
IX.4.b.	FLATPOWER 1300...2500.....	29
IX.5.	Condensate evacuation with condensate lift pump (optional).....	30
IX.5.a.	General information.....	30
IX.5.b.	Overview of the condensate lift pump kit.....	30
IX.5.c.	Operating principle.....	31
IX.5.d.	Maintenance	31
IX.5.e.	Performances and operating limits	31
X.	ELECTRICAL CONNECTION OF EXTERNAL DEVICES	31
X.1.	Remote control of low-speed forced operation (reduced operation)	31
X.2.	Remote control of high-speed forced operation (normal operation).....	32
X.3.	Remote stop control.....	32
X.4.	Remote fire protection control.....	32
X.5.	Control of supply shutoff damper - RMS.....	33
X.6.	Control of extract shutoff damper - RMR.....	33
X.7.	Night overventilation (Night cooling) signal (LOBBY version)	34
X.8.	Alarm output signal	34
X.9.	Remote firefighter stop - ADP	34
X.10.	Autonomous trigger detector – DAD.....	35
X.11.	Heat exchanger condensate lift pump (PRC).....	35
X.12.	CO / DXR coils condensate lift pump (PRC)	36
XI.	INTEGRATED CO/DXR COILS CONNECTION	36

XII.	CONNECTION OF REMOTE COILS IN DUCT	37
XII.1.	Remote hot water coil.....	37
XII.2.	Remote cold water coil.....	38
XII.3.	Remote changeover coil.....	40
XII.4.	Remote serial hot water + cold water coils.....	41
XII.5.	Remote reversible direct expansion (DXR) coil	42
XII.6.	Offset of the supply air temperature sensor SSG.....	43
XIII.	GENERAL OPERATION	43
XIII.1.	Thermal sequence initialisation	43
XIII.2.	Start up sequence.....	44
XIII.3.	Shutdown sequence (post-ventilation)	44
XIV.	STARTING UP	45
XV.	MAINTENANCE.....	46
XV.1.	Annual general checking	46
XV.2.	Checking filters	46
XV.3.	Removal and refitting of the exchanger condensate tray.....	46
XV.4.	Removal and refitting of the heat exchanger.....	48
XV.5.	Removal and refitting of CO/DXR coil condensate tray	50
XVI.	TROUBLESHOOTING - MAINTENANCE.....	51
XVI.1.	Connection and setting of the filter control pressure switch.....	51
XVI.2.	Connection and setting of the fan feedback pressure switches (ECO and DIVA versions)	52
XVI.3.	Connection and setting of the pressure transducers (LOBBY)	53
XVI.4.	Connection of pressure transducers (MAC2)	54
XVI.5.	Overheating safety thermostats THS and THSD.....	55
XVI.6.	Frost protection thermostat THA	56
XVI.7.	Replacing the internal memory battery	57
XVII.	WIRING DIAGRAMS.....	57
XVII.1.	Power wiring diagram –230V AC Single-phase power supply.....	58
XVII.2.	Power wiring diagram –400V AC 3-phases power supply.....	59
XVII.3.	Control wiring diagram – Pressure transducers and CO2 sensor	60
XVII.4.	Control wiring diagram – Pressure switches and bypass damper actuator	61
XVII.5.	Control wiring diagram – Temperature sensors.....	62
XVII.6.	Wiring diagram - Fan motors.....	63
XVIII.	GENERAL WIRING DIAGRAM OF OPTIONAL CUSTOMER'S EQUIPMENT	64
XIX.	EASY 5.0 CONTROL.....	66
XX.	SEASON CONTROL	66
XX.1.	General	66
XX.2.	Overview and constitution	66
XX.3.	Electrical compartments and user controls.....	67
XX.4.	General operating principle.....	68
XX.5.	User setting commands.....	68
XX.5.a.	Thermostat TH1 (heat recovery)	68
XX.5.b.	Thermostat TH2 (cold recovery)	68
XX.5.c.	Thermostat TH3 (frost protection).....	68
XX.6.	Connecting and setting external user devices.....	69
XX.7.	Troubleshooting and maintenance	69
XX.8.	General wiring diagram of the SEASON control system.....	70
XX.8.a.	FLATPOWER SEASON 600-900	70
XX.8.b.	FLATPOWER SEASON 1300 – 1800 – 2500.....	71
XXI.	AERAUIC PERFORMANCE CURVES	72
XXII.	COMMISSIONING REPORT	74

SAFETY AND ENVIRONMENTAL GUIDELINES

In accordance with the regulations in force, the installation and maintenance of the equipment must only be carried out by technically qualified personnel authorised for this type of equipment and work.

Use the necessary Personal Protective Equipment to avoid injury from electrical, mechanical (injuries from contact with metal sheets, sharp edges, etc.) and acoustic hazards.

Do not use the appliance for any purpose other than that for which it is designed. This device may only be used to convey air free of hazardous compounds, construction dust, etc.

Move the device as described in the chapter on handling.

Grounding must be done in accordance with the applicable standards. Never switch on an ungrounded appliance.

Before carrying out any work, make sure that the equipment is switched off and wait for the moving parts of the ventilation unit to come to a complete stop before opening the doors, panels and access hatches.

During operation, inspection and service panels, doors and hatches must always be fitted and closed.

The appliance can only be switched on and off via the isolator switch.

The safety and control equipment must not be removed, short-circuited or disabled.



The installation must comply with fire safety regulations.

All waste produced must be handled in accordance with the regulations in force.

It is the responsibility of the installer of the equipment to ensure compliance with the regulations concerning noise emissions inside the building and to adapt the installation and location conditions if necessary.

We accept no liability for damage resulting from misuse of the equipment, unauthorised repair or modification or failure to observe these instructions.

REMINDER AND DEFINITION OF PICTOGRAMS USED

	<p>Danger and warning:</p> <ul style="list-style-type: none"> ○ Operation or situation that may present a danger ○ Warning about instructions to follow
	<p>Reading the documentation that accompanies the product is mandatory.</p>

I. TECHNICAL SPECIFICATIONS

I.1. Electrical performance data

FLATPOWER	Motor power input (W)	Temp. Use (°C / °C)	Protection class	Thermal protection*	SEASON FIRST		SMART INFINITE CO		PREMIUM BE		INFINITE BE	
					Power supply voltage (V / Ph / Hz)	Current protection (A)	Power supply voltage (V / Ph / Hz)	Current protection (A)	Power supply voltage (V / Ph / Hz)	Current protection (A)	Power supply voltage (V / Ph / Hz)	Current protection (A)
600	2x169W	-20/60	IP54/B	ITP	230 / 1 / 50	2,8	230 / 1 / 50	8,2	230 / 1 / 50	8,2	230 / 1 / 50	13,7
900	2x220W	-20/60	IP54/B	ITP	230 / 1 / 50	3,4	230 / 1 / 50	14,3	230 / 1 / 50	11,0	230 / 1 / 50	21,9
1300	2x400W	-20/40	IP44/B	ITP	230 / 1 / 50	9,2	230 / 1 / 50	24,4	230 / 1 / 50	20,1	230 / 1 / 50	35,3
1800	2x400W	-20/40	IP44/B	ITP	230 / 1 / 50	9,2	230 / 1 / 50	25,5	230 / 1 / 50	25,5	400 / 3+N / 50	15,4
2500	2x400W	-20/40	IP44/B	ITP	230 / 1 / 50	9,2	230 / 1 / 50	32,0	230 / 1 / 50	32,0	400 / 3+N / 50	19,8

*ITP: Integrated Thermal Protection

I.2. Weights and dimensional data

FLATPOWER	Ø	A	A1	A2	B	C	E	E1	E2	F	F1	F2	G	G1
	mm	mm	mm	mm	mm	mm	mm	mm	mm	mm	mm	mm	mm	mm
600	250	2005	610	610	855	390	390	290	205	1355	245	245	80	155
900	315	2245	640	640	1040	485	495	325	255	1595	245	245	75	155
1300	355	2355	885	595	1295	485	600	405	255	1445	520	230	325	430
1800	400	2435	885	595	1295	565	600	405	290	1525	520	230	325	430
2500	400	2435	885	595	1815	565	900	545	290	1525	520	230	330	430

FLATPOWER	J	J1	J2	K	K1	L1	L2	L3	M1	M2	Ø T1	Ø T2 OUT	Ø T3 IN
	mm	mm	mm	mm	mm	mm	mm	mm	mm	mm	"	"	"
600	110	170	320	1265	310	365	-	-	172	95	1/2"	1/2"	3/8"
900	110	250	415	1420	405	550	-	-	172	95	1/2"	1/2"	3/8"
1300	110	250	420	1330	405	-	348	348	172	95	1/2"	5/8"	1/2"
1800	110	330	495	1415	485	-	348	348	172	95	1/2"	5/8"	1/2"
2500	110	330	500	1415	485	-	510	510	272	194	1/2"	3/4"	5/8"

FLATPOWER	FIRST SEASON SMART	PREMIUM BE	PREMIUM CO PREMIUM DXR	INFINITE BE	INFINITE CO INFINITE DXR
	kg	kg	kg	kg	kg
600	172	174	176	176	178
900	240	244	247	245	248
1300	297	300	306	300	308
1800	321	323	327	329	333
2500	418	423	431	425	433

FLATPOWER

Ceiling Energy Recovery Unit

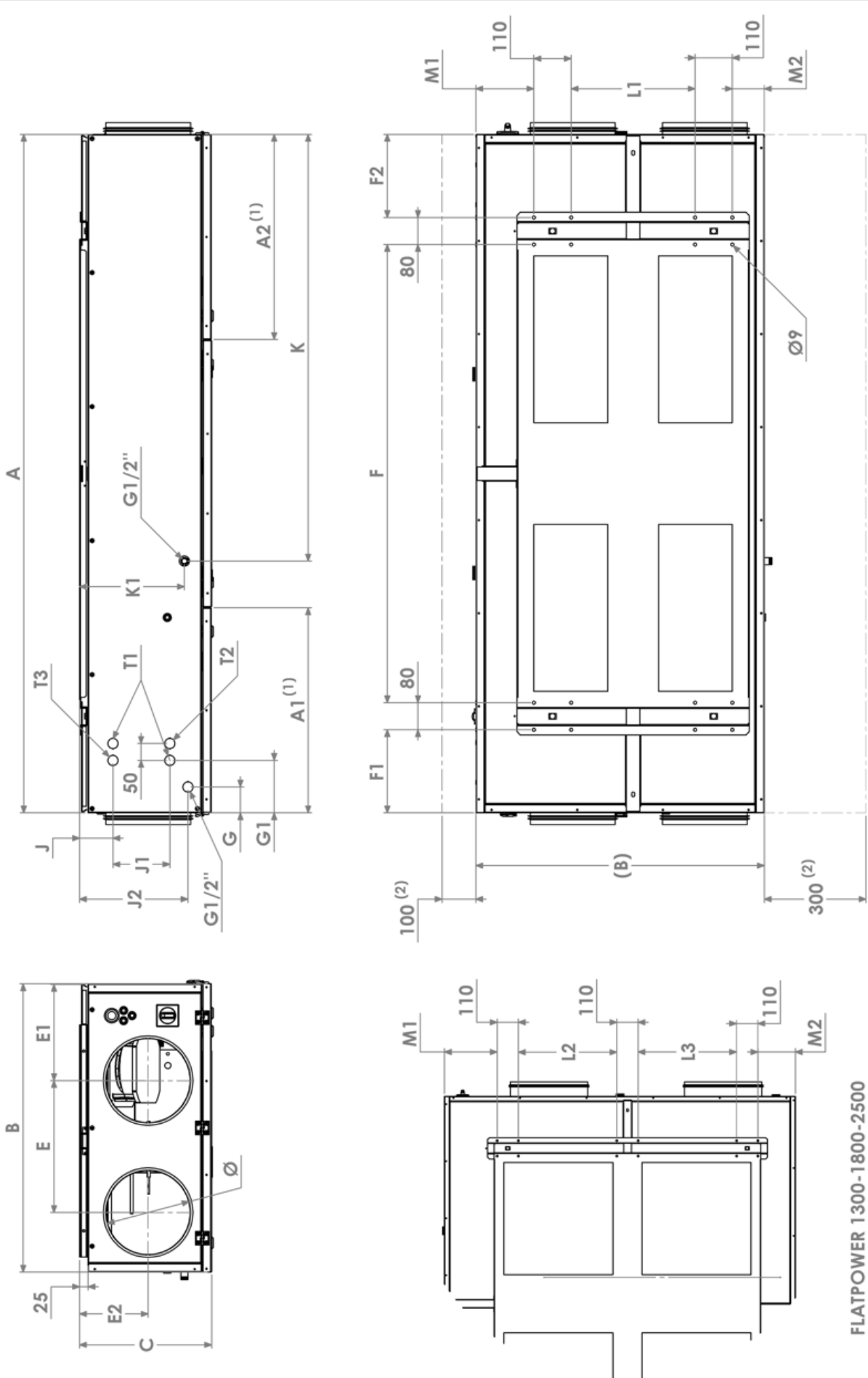

- (1) Clearance to opening panels.
- (2) Minimum clearance require.

II. GENERAL

FLATPOWER is a range of high-efficiency, plug & play, compact, single-piece indoor ventilation units designed for ceiling installation. The range is available in 5 sizes to cover unit flows up to 2500m³/h.

It is equipped as standard with the Zehnder Easy 5.0 controller, which provides intelligent ventilation and thermal management (except for the SEASON version, see chapter XX SEASON CONTROL). The Zehnder Easy 5.0 controller is a communicative device (Modbus RTU/TCP or Bacnet MSTP/IP) and has an integrated web server that is compatible with any HTML5 browser. The Zehnder Easy 5.0 controller is described in a separate manual.

	INTEGRATED THERMAL CONTROL AND EQUIPMENT			
	Electric Defrost Coil DBE	Electric Heating Coil BE	Changeover Coil CO	Reversible Direct Expansion Coil DXR*
FIRST				
SMART	✓			
PREMIUM BE		✓		
PREMIUM CO			✓	
PREMIUM DXR				✓
INFINITE BE	✓	✓		
INFINITE CO	✓		✓	
INFINITE DXR	✓			✓

*DXR : Reversible Direct Expansion Coil compatible with R407/R410A

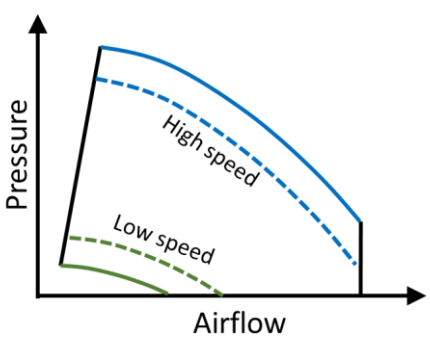
	Fan Control Type	Description
SEASON	Constant Speed (Without control system)	Fan speed can be adjusted manually by means of an individual potentiometer.
ECO	Constant Speed 	2 adjustable independent fan speeds. 2 independent time periods for each speed can be set.

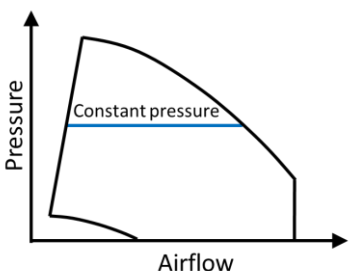
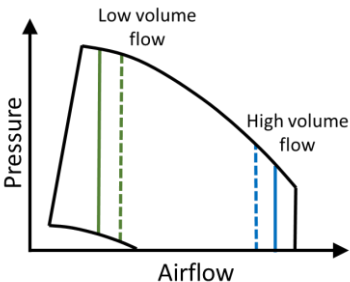
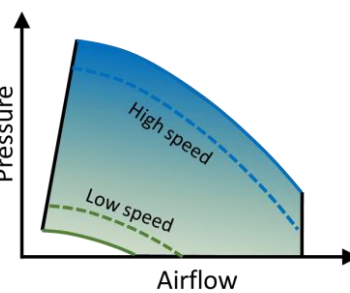
<p>LOBBY</p>	<p>Constant pressure</p> 	<p>2 adjustable independent fan pressures.</p> <p>2 independent time periods for each pressure can be set</p>
<p>MAC2</p>	<p>Constant air volume</p> 	<p>2 adjustable independent fan air volumes.</p> <p>2 adjustable independent time periods for each air volume.</p>
<p>DIVA</p>	<p>CO2 control via fan speed</p> 	<p>The fan speed varies continuously and proportionally between 2 fan speeds depending on the CO2 concentration measured at the extract.</p>

The FLATPOWER range is supplied as standard with a modulating bypass that provides the following functions:

- Protection against icing of the plate heat exchanger
- Management of the thermal recovery rate
- Free Cooling
- Night Cooling
- Free Heating

If you wish to extend the functional capabilities, the FLATPOWER range of ventilation units can be coupled with the

optional Combi Box modules, which allow the following coils to be installed in the duct:

- Cold water coil
- Reversible direct expansion coil (hot and/or cold)
- Changeover coil
- Hot water coil.

The EASY 5.0 controller can only accommodate:

- One heating coil + one cooling coil,
- One changeover coil alone.

The EASY 5.0 controller cannot accommodate:

- A heating and a cooling coil for dehumidification,
- A heating coil and a changeover coil.

III. UPON RECEIPT OF THE MATERIAL

III.1. Quality check

On receipt of the material, check the condition of the packaging and the material, as well as the number of packages. In case of damage, make detailed comments on the carrier's delivery note and inform your supplier immediately.

III.2. Unpacking

When unpacking the equipment, check the following points:

- Presence of total number of packages
- Presence of the expected accessories (electrical equipment, sleeves, (external) controls, etc.).

Remove the protective film from the sheets.

After unpacking the material, the waste must be disposed of according to local regulations and standards. No packaging should be released into the environment.

III.3. Storage

As long as the unit is not installed and connected to the air distribution network, it must be stored in a sheltered, dry place at a temperature between -20 °C and +40 °C as the packaging is not suitable for storage in bad weather.

IV. END OF SERVICE LIFE

Through its membership of the eco-organisation ECOLOGIC, CALADAIR meets the financing obligations for the collection, removal and treatment of waste electrical and electronic equipment.

When installing or uninstalling this equipment, the user or installer can contact the Ecologic company, which will offer a collection solution to dispose of the obsolete product in a suitable way.

Telephone: +33 (0)1 30 57 79 09

Internet: www.e-dechet.com

V. PACKAGING AND PACKAGES

The package comprises a wooden pallet on which the FLATPOWER ventilation unit rests in the top-lying position, and on which the fixing frame (A) rests. The whole unit is wrapped in protective plastic film. Sensitive parts are protected by cardboard or bubble-wrap.

In the LOBBY constant pressure version (1300-1800-2500 Models), the unit is delivered with a package containing a pressure tap and a crystal tube to be connected to the supply duct during installation.

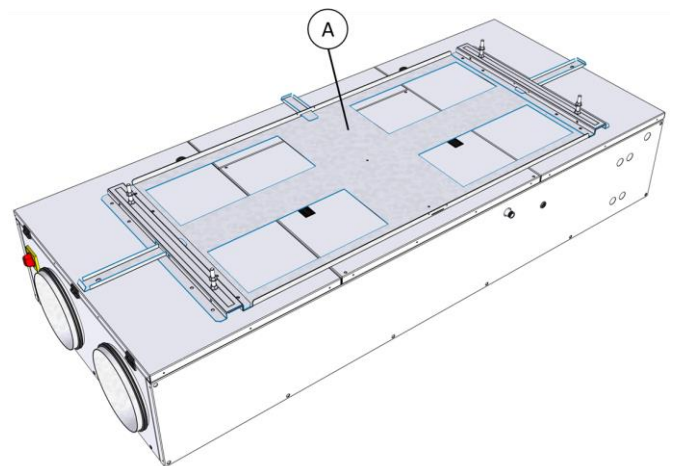

VI. IDENTIFICATION AND LABELLING

The fan unit is identified by a label on the front near the isolator switch:

1 2 3

FLATPOWER 600 INFINITE CO DIVA

HIGH EFFICIENCY RECOVERY UNIT / CENTRALE DOUBLE FLUX HAUTE EFF

230 V	1~	50 Hz	4 5 6 7
CHANGEOVER	WATER / EAU	8 bar/105°C maxi	
DEFROST / DEGIVRAGE	ELECTRIC / ELECTRIQUE	1,25kW	
I Max : 8,2 A			
NOMINAL AIRFLOW / DEBIT NOMINAL : 504 m³/h		VDI 6022 CERT. N°XXX No XXX/XXX/XXX	
FRESH AIR AIR NEUF	FILTER / FILTRE : 1 X F7 ePM1 55% - 275x275x48 mm MAX REPLACEMENT PRESSURE DROP / PERTE DE CHARGE MAX DE REMPLACEMENT : 163 Pa NOMINAL FILTER PRESURE DROP / PERTE DE CHARGE NOMINAL DU FILTRE : 63 Pa		
EXTRACT AIR AIR REPRIS	FILTER / FILTRE : 1 X M5 ePM10 50% - 275x275x48 mm MAX REPLACEMENT PRESSURE DROP / PERTE DE CHARGE MAX DE REMPLACEMENT : 115 Pa NOMINAL FILTER PRESURE DROP / PERTE DE CHARGE NOMINAL DU FILTRE : 38 Pa		

CDF047050

225693-030

Manufactured by ZEHNDER CALADAIR INTERNATIONAL 61 rue de Saint Veran - 71000 MACON LOCHE - FRANCE

N° 21.03.072

8

1	Unit size
600	See aeraulic performance curves: XXI AERAULIC PERFORMANCE CURVES
900	
1300	
1800	
2500	
2	Type of control and integrated thermal equipment
SEASON	Fan control via potentiometer and heat recovery control via thermostats (no Easy 5.0 control).
FIRST	EASY 5.0 0 controller without integrated coil
SMART	EASY 5.0 controller with integrated electric defrost coil (DBE)
PREMIUM BE	EASY 5.0 controller with integrated electric heating coil (BE)
PREMIUM CO	EASY 5.0 controller with integrated electric changeover coil (CO)
PREMIUM DXR*	EASY 5.0 controller with integrated reversible direct expansion coil (DXR)

FLATPOWER

Ceiling Energy Recovery Unit

INFINITE BE	EASY 5.0 controller with control of integrated electric defrosting coil and integrated electric heating coil (DBE + BE)
INFINITE CO	EASY 5.0 controller with control of the integrated electric defrosting coil and the integrated changeover coil (DBE + CO)
INFINITE DXR*	EASY 5.0 controller with control of the integrated electric defrosting coil and the integrated reversible direct expansion coil (DBE + DXR)
3	Fan control type
ECO	Constant speed
LOBBY	Constant pressure
MAC2	Constant volume
DIVA	CO2 in variable speed
4	Power supply
400V - 3~ + N - 50Hz	Three-phase + Neutral
230V - 1~ - 50Hz	Single-phase
5	BE : Electric heating coil power input (kW) CO : Changeover coil Temperature/Maximum pressure DXR : Refrigerant (R407/R410A) / Maximum operating pressure (PS)
6	Characteristics of the defrosting coil (DBE)
7	Maximum input current (A)
8	Production number to be mentioned in any communication with the supplier

*See XI INTEGRATED CO/DXR COILS CONNECTION in order to check compatibility with the third-party thermodynamic module.

VII. OVERVIEW AND CONSTRUCTION

VII.1. General overview of the unit

FLATPOWER 600 - 900

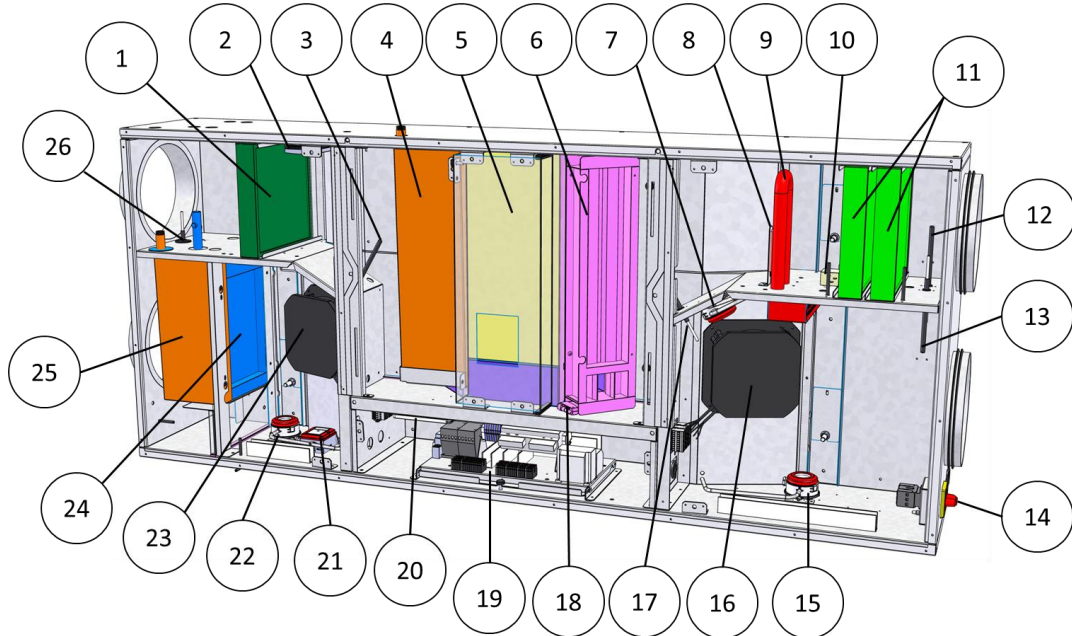

FLATPOWER 1300 - 1800 - 2500

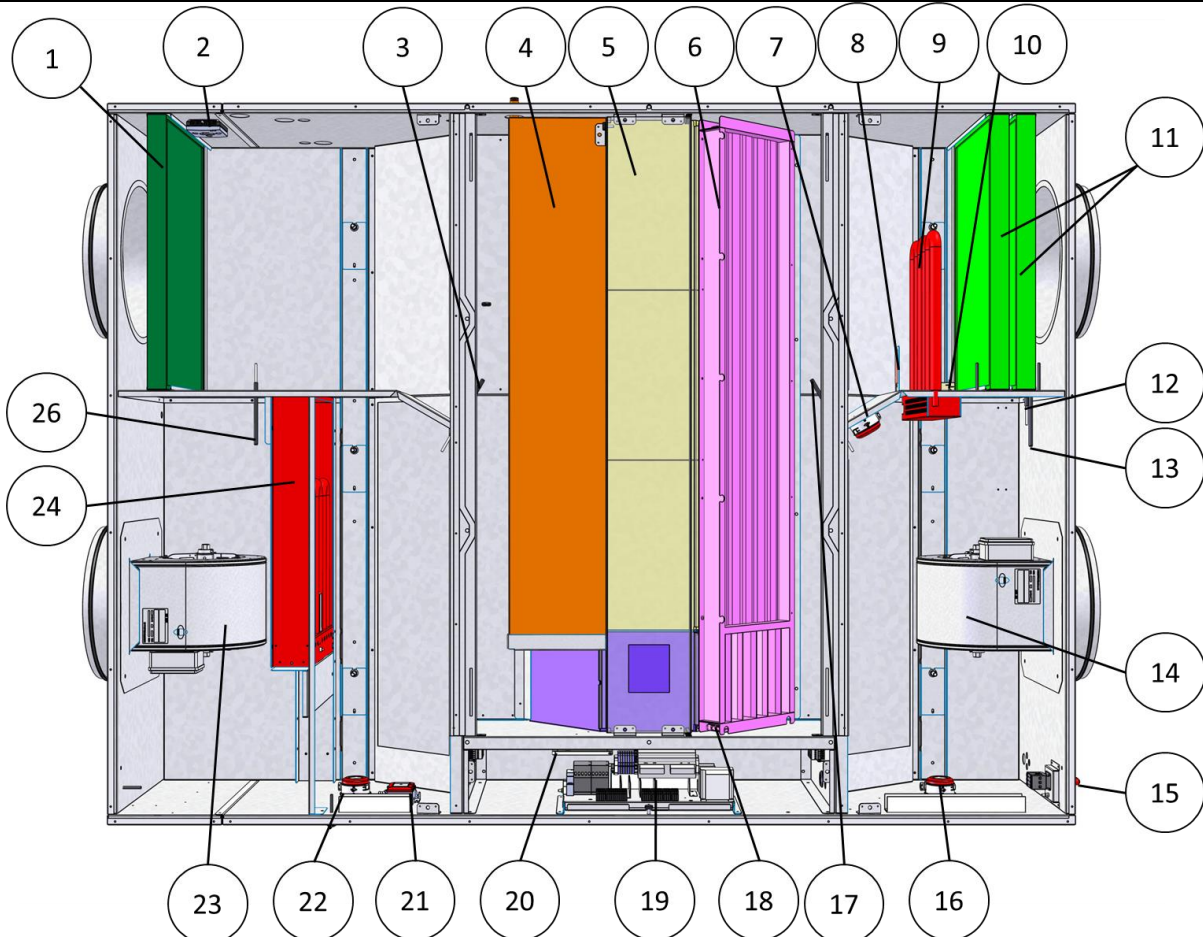

FLATPOWER

Ceiling Energy Recovery Unit

Mark	Designation	Component
1	FR	Extract Filter
2	CO2	CO2 Sensor (DIVA versions)
3	SRG	Extract temperature sensor
4	BACR	Heat exchanger condensate tray
5	REC	Plate heat exchanger (recuperator)
6	BIM	Bypass damper
7	DEP FS	Supply filter pressure switch (intake air)
8	BTHSD	Overheating safety thermostat bulb of defrost electric coil (DBE)
9	DBE	Defrost electric coil (SMART / INFINITE versions)
10	THSD	Overheating safety thermostat of defrost electric coil (DBE)
11	FS	Supply filter (double-stage filtration available as an option)
12	SEG	Outdoor temperature sensor (fresh air)
13	SDG	Defrost temperature sensor
14	IG	Main power isolator switch
15	DEP R	Extract Air Fan (VAR) operation feedback pressure switch (ECO/DIVA versions)
	TRP R	Extract Air Fan (VAR) pressure transducer (MAC2 versions)
16	VAR	Extract Air Fan
17	SBD	Defrost coil temperature sensor (SMART / INFINITE versions)
18	SM	Bypass damper actuator
19	REG	Sliding electric board
20	PG 5.0	Mobile wired touch control
21	TRP R	Extract Air Fan (VAR) pressure transducer (LOBBY versions)
22	DEP S	Supply Air Fan (VAS) operation feedback pressure switch (ECO/DIVA versions)
	TRP S	Supply Air Fan (VAS) pressure transducer (LOBBY/MAC2 versions)
23	VAS	Supply Air Fan

24	BE	Electric coil
	CO	Changeover coil
	DXR	Reversible direct expansion coil
25	BACB	Condensate tray for CO / DXR coils
26	SSG	Supply air temperature sensor
---	BTHA	Frost protection thermostat bulb (not visible, see XVI.6 Frost protection thermostat THA)
---	THA	Frost protection thermostat (PREMIUM CO and INFINITE CO version) (not visible, see XVI.6 Frost protection thermostat THA)
---	BTHS	Overheating safety thermostat bulb of electric heating coil (not visible, see XVI.5 Overheating safety thermostats THS and THSD)
---	THS	Overheating safety thermostat switch of electric heating coil (not visible, see XVI.5 Overheating safety thermostats THS and THSD)

VII.2. Sliding electric board

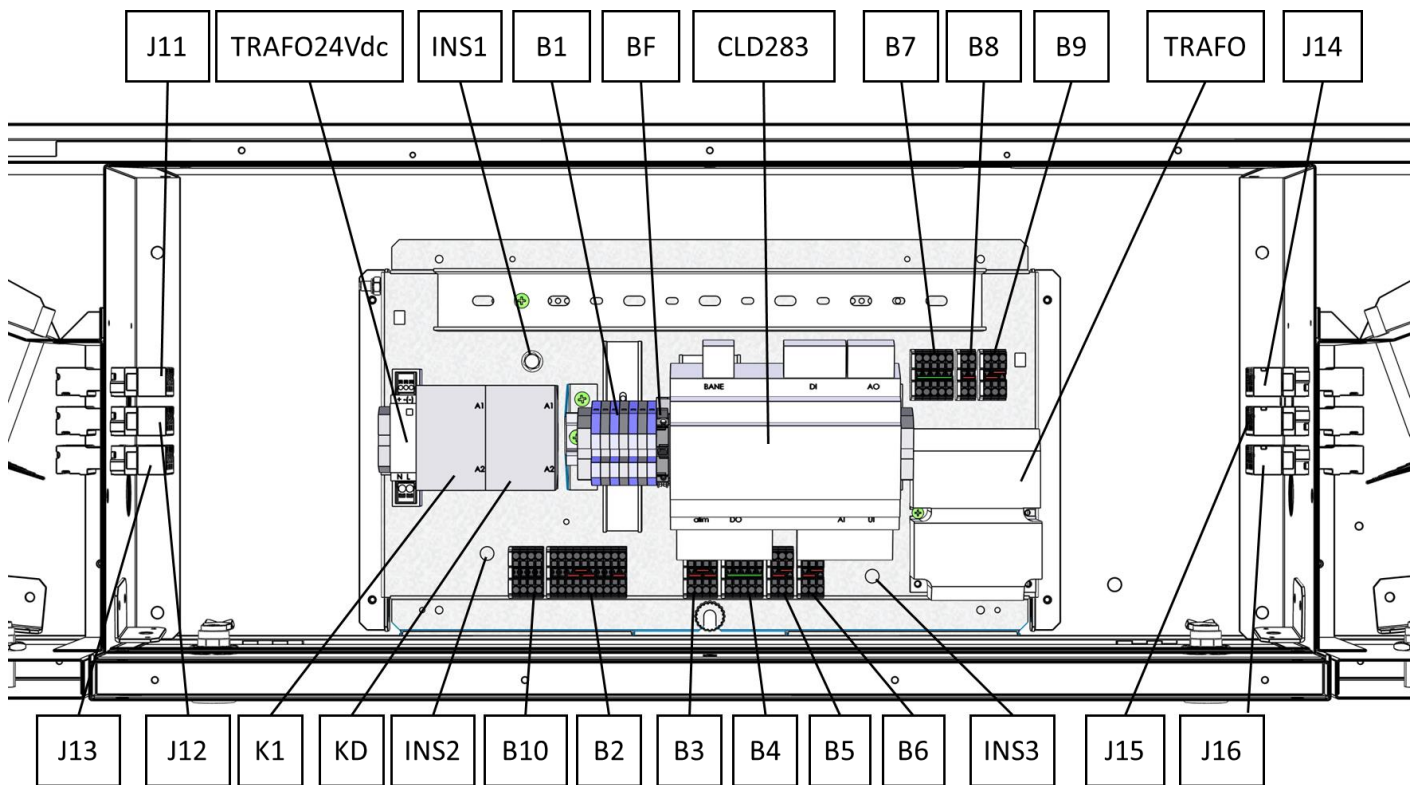

Mark	Components
J11...J16	Plug-in connectors
TRAFO	Control transformer 230Vac / 24Vac
TRAFO24Vdc	Control transformer 230Vac / 24Vdc (PG 5.0 power supply)

INS1...INS3	Inserts for protective earth PE connection
CLD283	Electronic controller EASY 5.0
B1...B10	Control terminal blocks
K1	Electric heating coil (BE) contactor
KD	Defrost electric heating coil (DBE) contactor
BF	Fuse holder terminal 3.15A T

VII.3. Control terminals and user connections

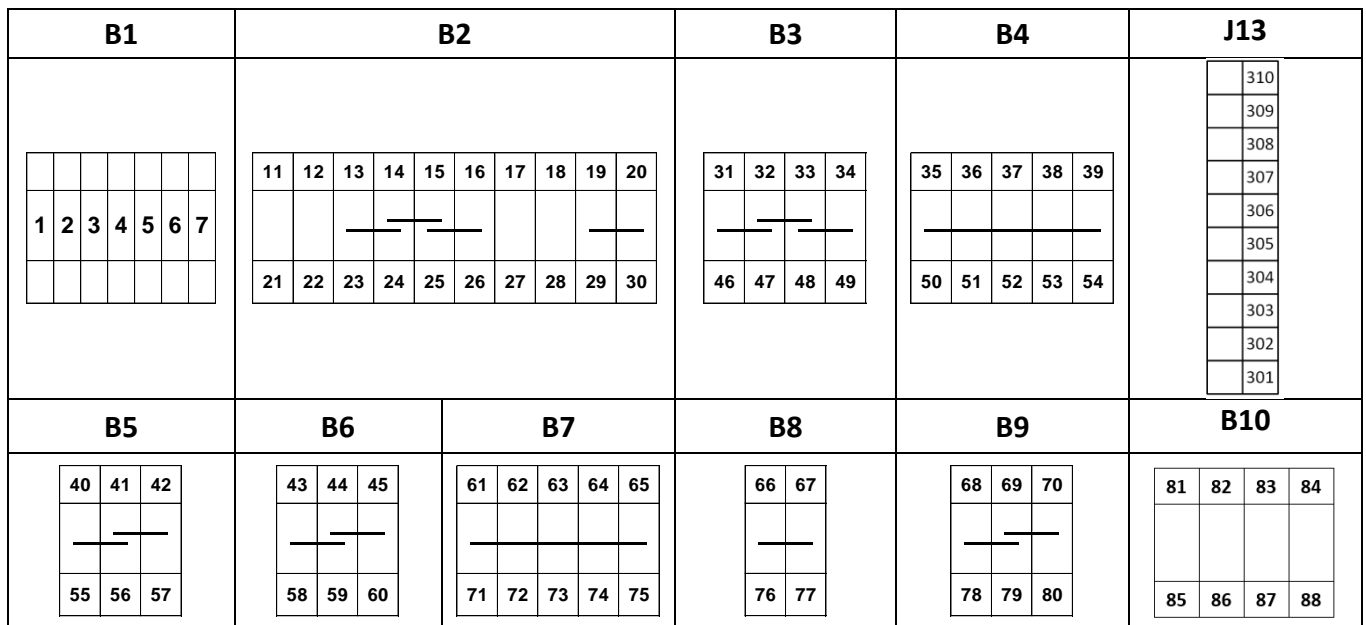

Designation	Definition	Terminals	Connection
ADP	Remote fire stop	12-13	To be connected to the terminals of an NC (normally closed) contact of the remote fire stop device. (Shunt between terminals (12)-(13) at the factory)
DAD	Autonomous trigger detector	83-84	To be connected to the DAD fault contact. (Shunt between terminals (83)-(84) at the factory)
THA	Frost protection thermostat	305-306 Connector J13	To be connected to the terminals (C) and (2) of the defrost thermostat (THA) (PREMIUM CO and INFINITE CO versions equipped with changeover CO coil). Shunt between terminals (305)-(306) at the factory (FIRST/SMART versions).
THS	Overheating safety thermostat	305-306 Connector J13	To be connected to the terminals (C) and (2) of the overheating safety thermostat THS (PREMIUM BE and INFINITE BE version equipped with electric heating coil). Shunt between terminals (305)-(306) at the factory (FIRST/SMART versions).
EDT2	Power supply +24Vdc for room touch control EDT2	30-60	To be connected to the (N) and (+24V) terminals of the EDT2 room touch control respectively (observe polarity).
LS	Low Speed remote order	73 + DI3 of the controller	To be connected to an external NO (normally open) dry contact
HS	High speed remote order	74 + DI4 of the controller	To be connected to an external NO (normally open) dry contact

STOP	Stop remote order	75 + DI5 of the controller	To be connected to an external NO (normally open) dry contact
3WV HC	3-way valve for hot water heating coil	76 + 78 + AO1 of the controller	To be connected to the modulating 3-way valve of the hot water coil (see XII.1 Remote hot water coil)
3WV CC	3-way valve for cold water-cooling coil	77 + 79 + AO3 controller	To be connected to the modulating 3-way valve of the cold water coil (see XII.2 Remote cold water coil)
3WV CO	3-way valve for changeover coil CO	76 + 78 + AO1 + AO3 of the controller	To be connected to the modulating 3-way valve of the changeover water coil (see XII.3 Remote changeover coil)
HEATING OUTPUT	Pump for hot water heating coil	49 + DO3 of the controller	To be connected to the ON/OFF switch of the hot water circulator (Attention: 24V AC output to be relayed) (see XII.1 Remote hot water coil)
COOLING OUTPUT	Pump for cold water cooling coil	48 + DO4 of the controller	To be connected to the ON/OFF switch of the cold water circulator (Attention 24V AC output to be relayed) (see XII.2 Remote cold water)
AL	Alarm indicator output	47 + DO5 of the controller	24V output available if the unit is faulty. (Attention 24V AC output to be relayed)
NC Overventilation	Night Cooling (night overventilation)	47 + DO7 of the controller	24V output available for opening the terminal dampers during night cooling (LOBBY version) (Attention 24V AC output to be relayed)
RMS	Supply motorised shutoff damper	32 + DO1 of the controller	To be connected to terminals (1) and (2) of the supply motorised damper
RMR	Extract motorised shutoff damper	31 + DO2 of the controller	To be connected to terminals (1) and (2) of the extract motorised damper
Heat Exchanger PRC	Heat exchanger condensate lift pump	1-2	Power supply to be connected on the wire of the pump: - Blue wire (neutral) on the terminal (1) - Brown wire (phase) on the terminal (2)
LS1	Level switch of heat exchanger condensate lift pump	81-82	Level switch LS1 to be connected on the terminals: - Black wire on the terminal (81) - Grey wire on the terminal (82)
CO / DXR coils PRC	CO / DXR coils condensate lift pump	1-2	Power supply to be connected on the wire of the pump: - Blue wire (neutral) on the terminal (1) - Brown wire (phase) on the terminal (2)
LS2	Level switch of CO / DXR coils condensate lift pump	86-87	Level switch LS2 to be connected on the terminals: - Black wire on the terminal (86) - Grey wire on the terminal (87)

VIII. INSTALLATION

VIII.1. Handling

The ventilation unit may only be transported in its installation position.

Adapt the choice of handling equipment to the weight of the equipment received (refer to the weight given at the beginning of the document, see I.2 Weights and dimensional data).

VIII.2. Permitted installation configurations and precautions to be taken

The FLATPOWER unit has no roof and should only be installed suspended indoors. In the case of a false ceiling, it must be able to allow doors to be opened to access inside the unit.

	Observe the permissible loads for the support (ceiling, slab, threaded rods, etc.). The weights of each model are given in the technical specifications, see I.2 Weights and dimensional data. Take into account the weight of optional accessories.
--	--



It is designed for suspended mounting using the mandatory fixing frame delivered with the unit.

In general, install the unit in such a way that the ambient temperature cannot damage the internal the internal components of the unit during set-up and operation.

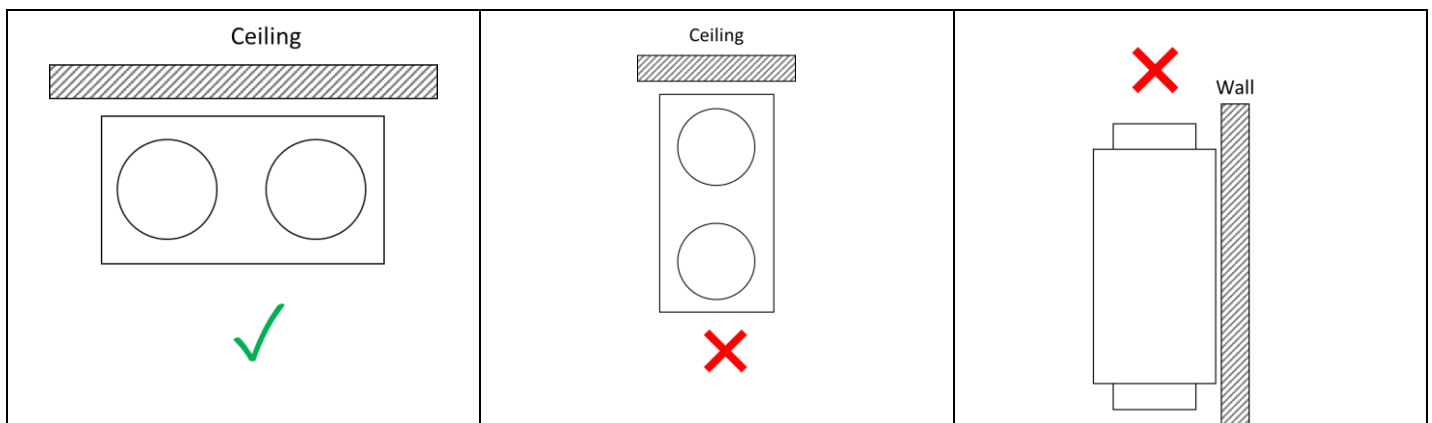
The unit must always be horizontal. Vertical installation is not permitted:



VIII.3. Horizontal lifting

	Pay particular attention to the phase when you lift the product off the floor and place it on the floor, to avoid shocks that could damage the structure and integrity of the product.
	If the unit is transported by crane, use a lifting beam and strap the product to keep it in the transport position (horizontal airflow).
	When turning the unit over from its delivery position, tilt the unit so as not to damage the components on the sides (hinges, pressure taps, condensate tray tapping), using protective covers or, for example, rafters laid on the ground transversely to the unit.

Favour support areas set back from the locks and hinges shown on the picture opposite.

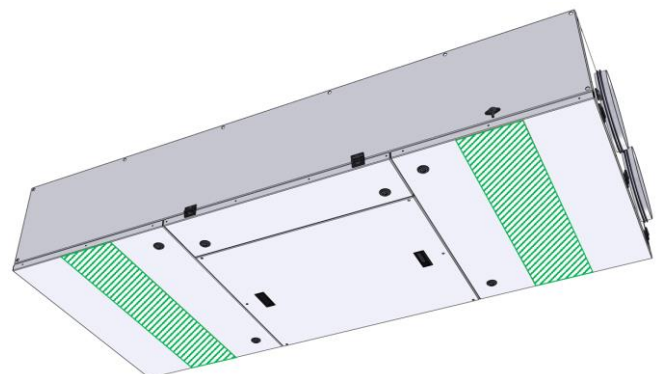

FLATPOWER

Ceiling Energy Recovery Unit

Before any operation, check that the installation supports are able to support the weight of the ventilation unit with all its accessories and options.

The fixing frame must always be attached to the top panel of the unit in order to ensure the sealing around the mounting screws.

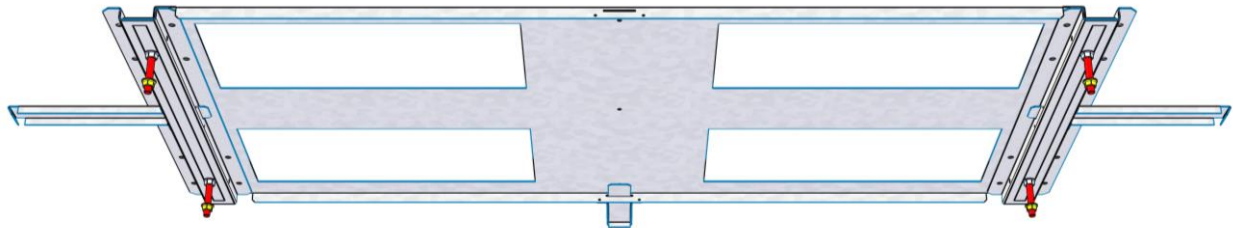

Fixing frame supplied with the unit which also serves as an assembly plate

VIII.3.a. Fixing the frame to the ceiling

Step		Description
1	<p>Bring the fixing frame supplied with the unit.</p> <p>Check the presence of nuts (A) on the screws of the fixing frame.</p> <p>Engage the nuts on the screws about 10mm.</p>	
2	<p>Position the fixing frame where you want it and fix it using the 4 holes (B) made in each end.</p> <p>Maintain a minimum distance between the end of the part (E) and the wall. This distance is necessary to ensure that the access doors can be opened.</p>	
3	<p>Fix the 3 template plates (C) at their ends using the fixing holes (D).</p>	

FLATPOWER

Ceiling Energy Recovery Unit

Maintain a minimum distance (see I.2 Weights and dimensional data) between the unit and the wall in order to open the access door to the control box and lower the electric board as shown in the drawing below.

A distance greater than 200mm allow to increase the opening angle of the access door to the control compartment on the second position to facilitate access to the electric board.

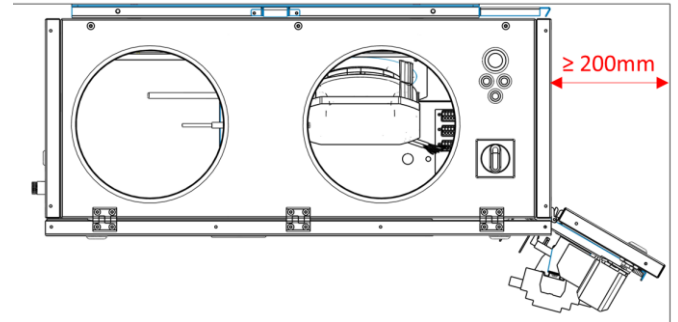
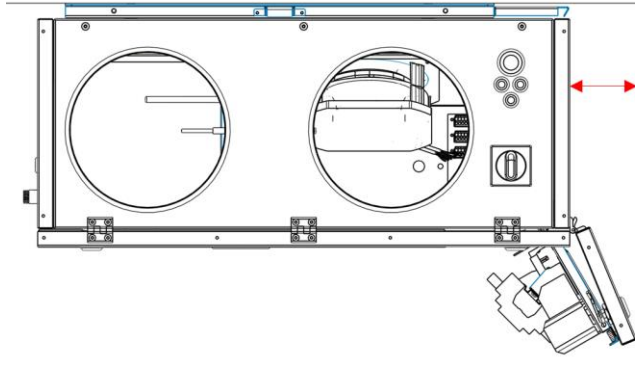



VIII.3.b. Positioning the unit on the fixing frame

Etape	Description	Description
1	<p>Place the unit in a horizontal position with the doors underneath and remove the shutter plates (A).</p> <p>Keep the plates and screws that will be used in step (8).</p>	
2	<p>Approach the unit near the screws (B) of the fixing frame previously installed at a distance of about 105mm.</p> <p>At the step, the screws (B) are still set back from above the unit.</p>	
3	<p>Adjust the position of the unit laterally in relation to the two side plates acting as visual templates.</p>	

FLATPOWER

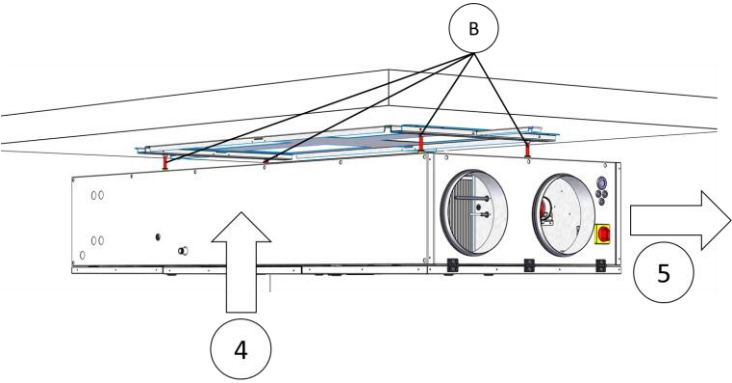
Ceiling Energy Recovery Unit

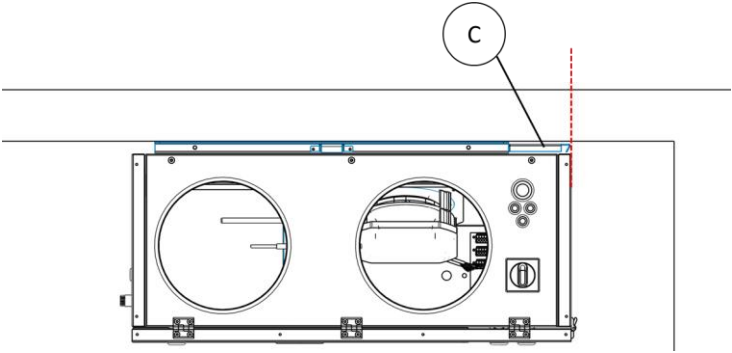
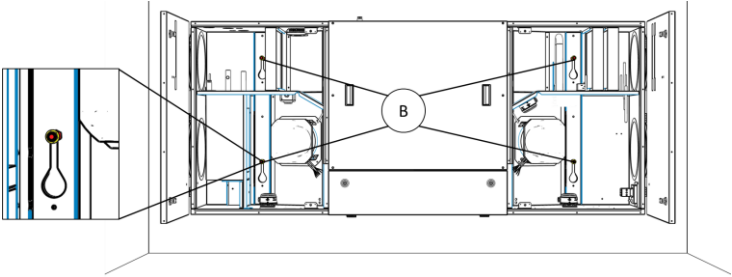
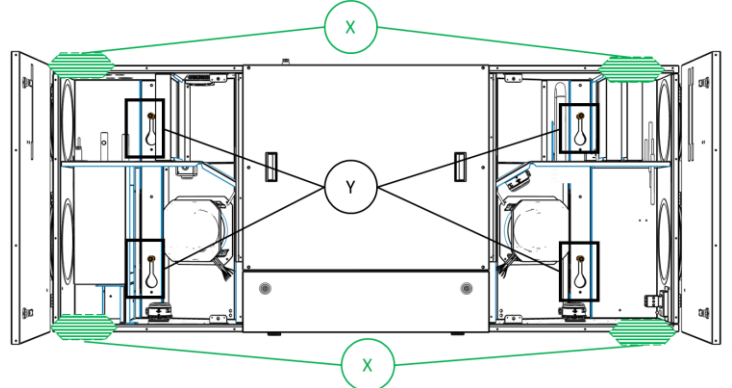
4	<p>Raise the unit to flush with the fixing frame and so that the screws (B) pass through the top panel of the unit.</p>	
5	<p>Push the unit until the screws are stopped in their housing. The visual template of the fixing frame shall be aligned with the side panel of the unit.</p> <p>The unit is correctly engaged when the visual template (C) is aligned with the side panel.</p> <div data-bbox="204 896 734 1030" style="border: 1px solid black; padding: 5px;">  <p>At this moment, the unit is maintained but not locked. Be vigilant about the following operations.</p> </div>	
6	<p>Lower the lifting device to release the unit. Open the 2 side doors. The screws (B) are stopped in their housing.</p>	
7	<p>Using the lifting device, lift the unit slightly to one side only, leaning on the edges (X) of the side panels while leaving sufficient space (Y) to access the screws (B).</p>	

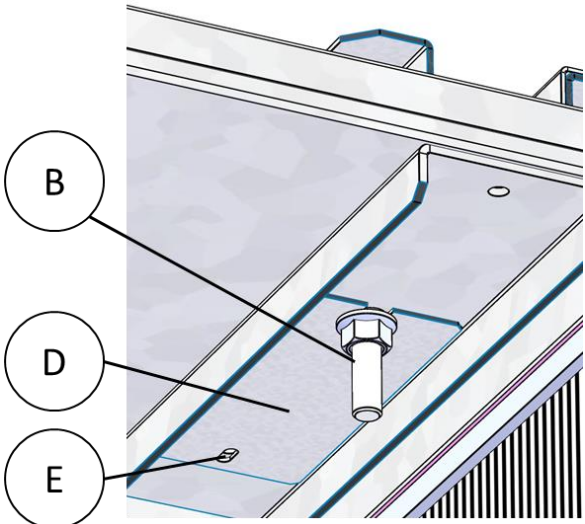
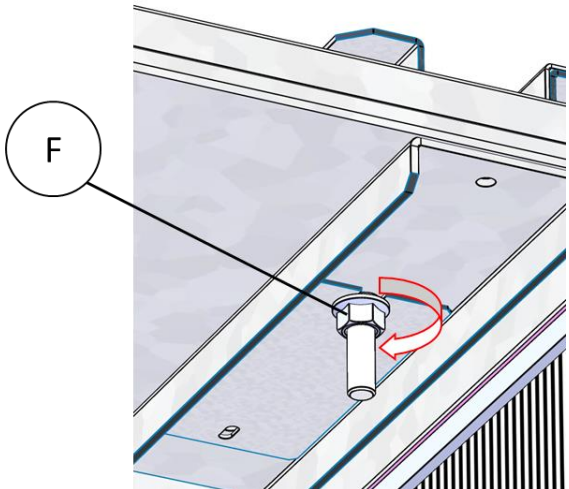
<p>8</p>	<p>Place the shutter plates (D) previously removed in step (1) on each fixing screw (B) between the nut and the cross beam and secure them with screws (E) in the holes provided for this purpose. Proceed in the same way on each point of attachment of the plant.</p> <p>The shutter plates (D) now provide the translation clamping of the unit on the fixing frame attached to the ceiling.</p>	
<p>9</p>	<p>Lower and permanently remove the lifting device.</p>	
<p>10</p>	<p>Screw the nuts (F) from inside the unit in a distributed manner until the unit is stopped by the fixing frame.</p>	

VIII.3.c. Installation of the unit offset from the ceiling

The unit can also be offset from the ceiling.

The fixing frame must always be attached to the top panel to ensure sealing of the unit.

In this case, lose the 4 screws (B) M10x70 and replace them by threaded rod M10.

Allow the threaded rod to protrude 70mm below the fixing frame.

Ensure that the attachment of threaded rod in the ceiling is strong enough to be able to withstand:

- Unit weight itself and any options mounted on it
- Installation loads
- Maintenance/operation loads.

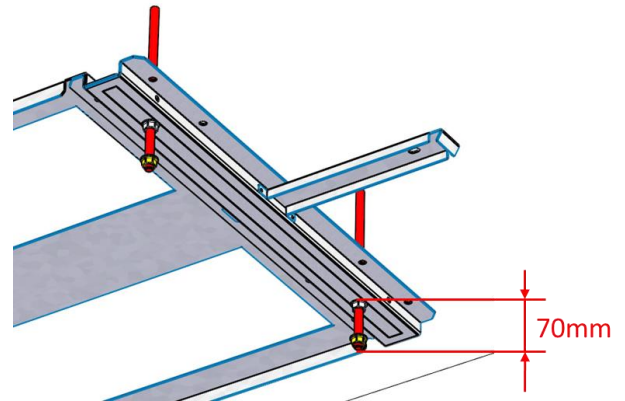
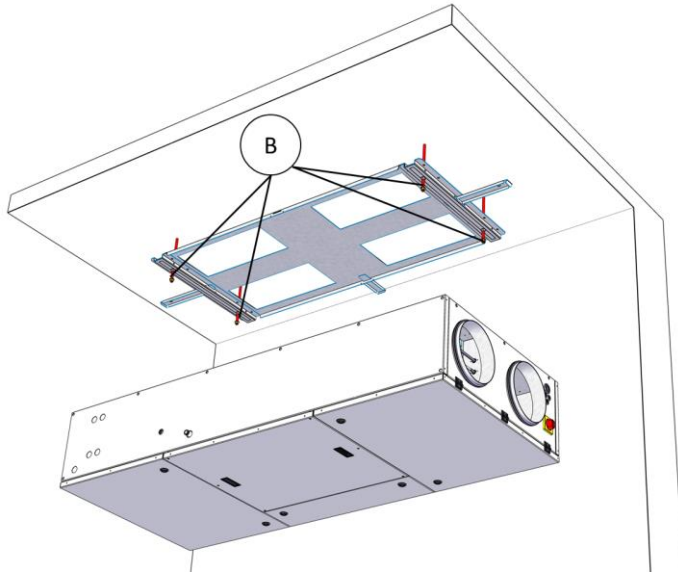

VIII.4. Access inside the unit

The unit features 3 hinged doors (A), (B) and (C) and a removable door (D) allowing access to the various internal components.

The doors (A), (B), and (C) features locking locks (8mm Hex Allen type key wrench).

The doors (A) and (B) features a retaining tie beam (E) which must be re-engaged at each door closing.

The removable panel (D) is fixed on its perimeter by Poêlier type screws (requires a wide flathead screwdriver).

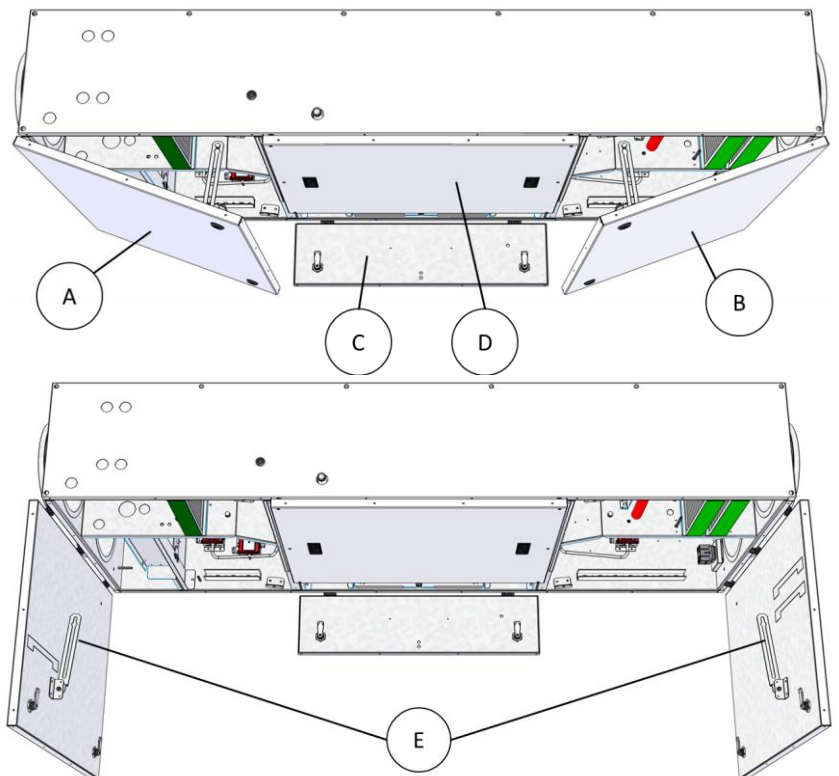

Always re-engage the retaining tie beam (E) of doors (A) and (B) when closing.

VIII.5. Access to the sliding electric board and user touch control

Opening the access door to the electric compartment allow to access to the electric control board and to the user touch control.

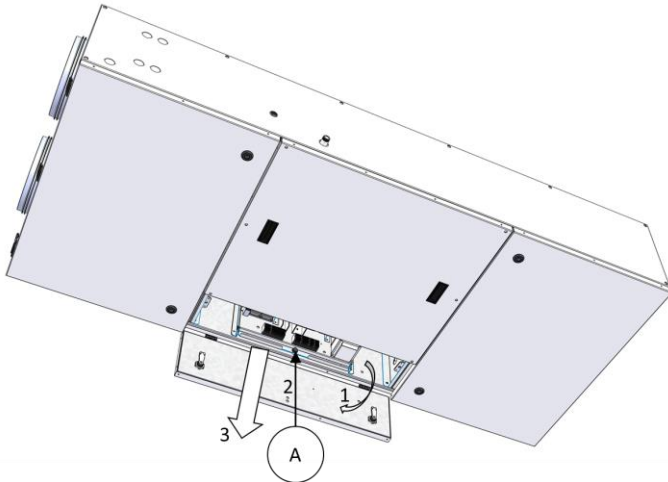

Electric board in « closed » position

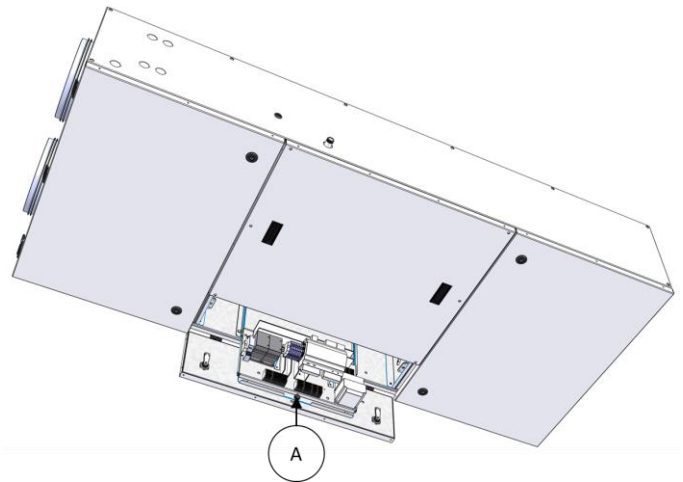

Electric board in « opened » position

- (1) Open the access door to the electrical compartment,
- (2) Remove the knurled head screw (A),
- (3) Slide the electric board,
- (4) Secure the electric board using the knurled head screw (A) previously removed.

The electrical compartment contains the removable wired touch control (B). A support (C) with pins is provided for its fixation.

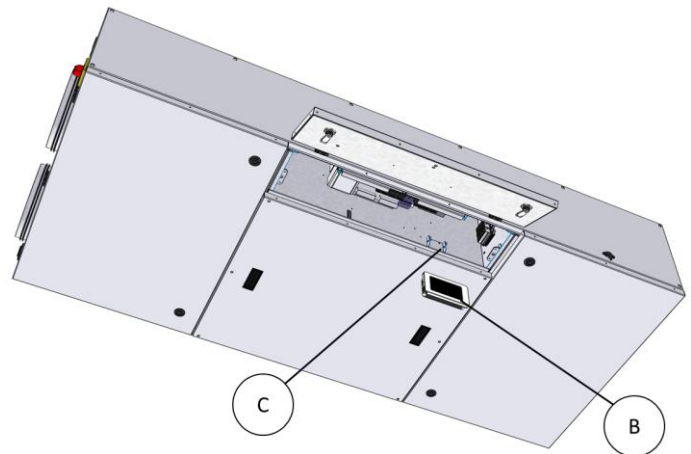
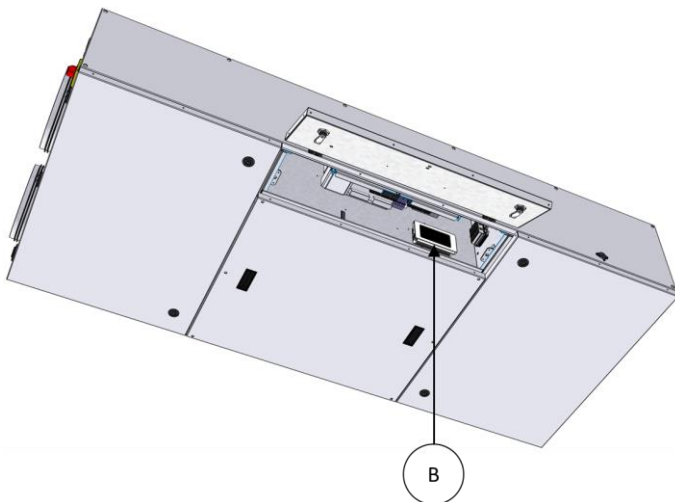

VIII.6. Connection of the supply pressure tap (LOBBY)

On FLATPOWER 1300-1800-2500 LOBBY version, connect the supply pressure tap (1) to the supply air duct pipe using the pressure tap (2) and the crystal tube (3) supplied with the unit. Observe a distance of at least 2.5 times the diameter of the duct.

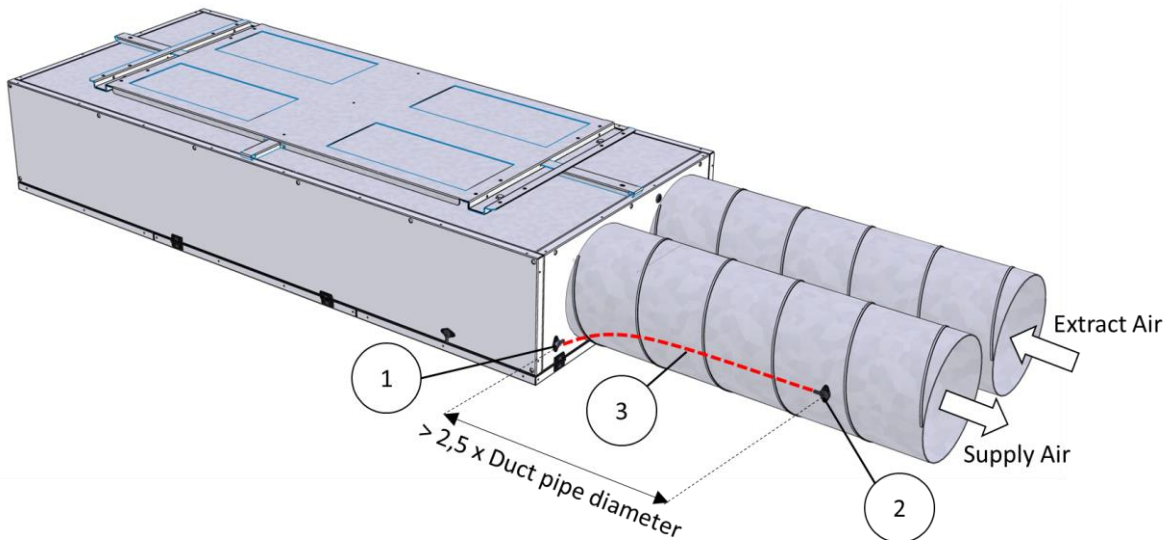

VIII.7. Installation of filters clogging manometer

The ventilation unit can be equipped with optional (Caladair reference: OPT004223) filters clogging manometers including:

- 1 graduated liquid column manometer to be filled on site (measuring range 0-1000 Pa)
- 1 container of coloured filling liquid
- 2 pressure taps
- 1m of transparent crystal connection tube
- Small items (screws, brackets).

Allow 1 kit per filter to be fitted (2 kits per ventilation unit).

The installation of all components is the responsibility of the installer.

The panels that support the pressure taps are pre-drilled at the factory for easy installation.

If the system must be compliant with VDI6022 requirements, all filters shall be equipped with filter clogging control manometers. This option is mandatory to ensure VDI6022 compliancy.

FLATPOWER

Ceiling Energy Recovery Unit

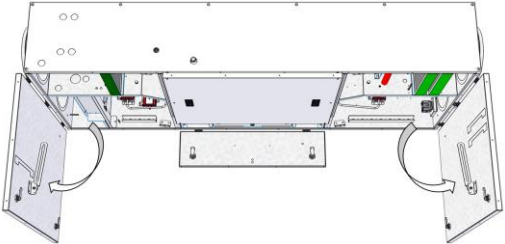
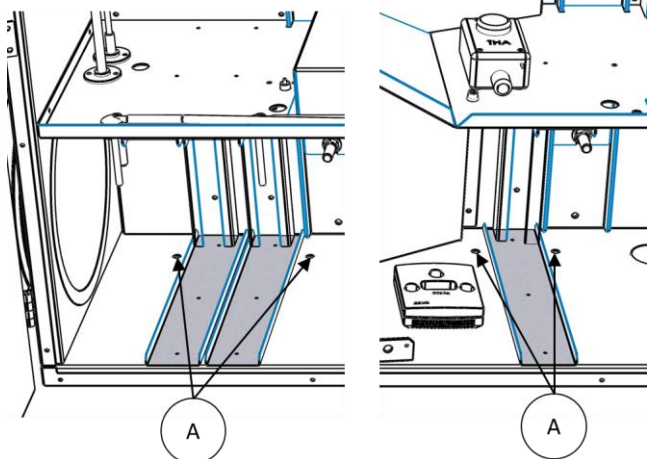
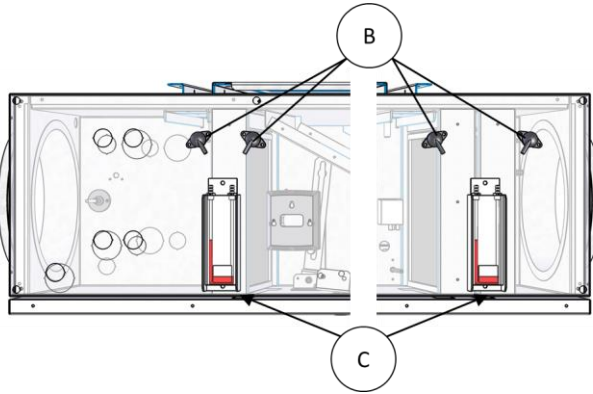
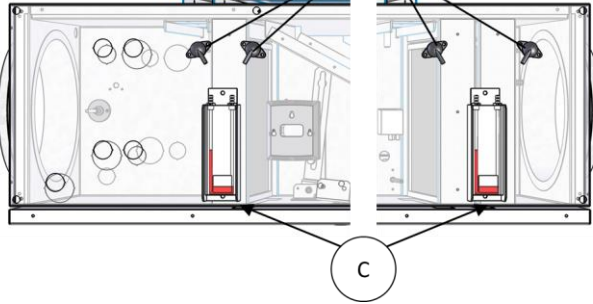
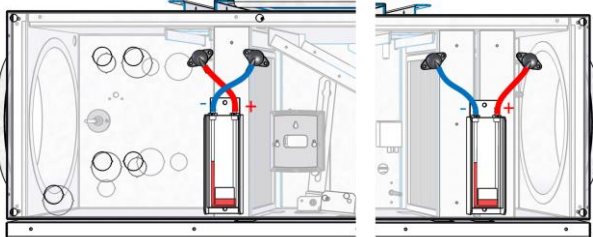
Step	Description	Details
1	<p>After completely shutting down the unit, fully open the 2 access doors and remove the supply and extract filters.</p> <p>Note: bring an 8mm Allen type key wrench.</p>	
2	<p>Visually locate the upper holes (A) pre-drilled at factory on the inner envelope of the side panel near the filters and drill (diameter 10mm) on either side the 2 sheets forming the double envelope of the panel using a drill bit suitable for metal sheets drilling.</p>	
3	<p>Sweep or vacuum the shavings to prevent them from entering the liquid column manometer and the fan unit when refitting.</p>	
4	<p>Pre-position the 2 pressure measurement taps on the external face of the panels in the holes previously made.</p>	<p>Extract filter side Supply filter side</p> 
5	<p>Pre-position the pressure measurement devices on the outside of the panels, as low as possible below the level of the 2 pressure measurement taps (B). Ensure that the measuring devices are vertical when finally reassembled and that the bottom of the measuring devices don't beyond the bottom of the lower edge of the side panel (see mark (C)).</p>	
6	<p>Taking into account the (+) and (-) terminals, connect the pressure measurement taps to the measuring device using the transparent crystal tube and adjust the length so that there is no risk of bending, which could affect the measurement.</p> <p>The pressure taps upstream of the filter in the air flow is connected to the terminal (+) of the liquid column manometer.</p> <p>The pressure taps downstream of the filter in the air flow is connected to the terminal (-) of the liquid column manometer.</p>	<p>Extract filter side Supply filter side</p> 

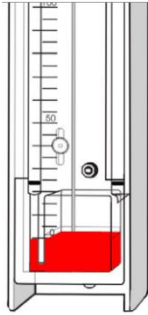
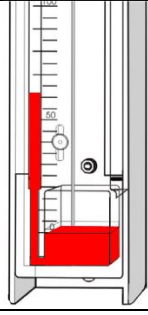
7	Hold the components in position and secure them with the self-drilling screws provided. Pre-drilling is not necessary.	
8	Refit the filters previously removed and close the 2 access doors. Re-engage the opening tie rod.	
9	<p>Fill the manometers using the container provided:</p> <ul style="list-style-type: none"> ▪ Unscrew the left-hand connector piece (-) after disconnecting the transparent crystal tube ▪ Slowly pour in the liquid to the zero mark ▪ Replace the connector piece (tighten it firmly but moderately) and reconnect the transparent crystal tube ▪ If necessary, adjust the position of the graduated ruler to adjust the zero point. <p>Keep the rest of the container for possible future refilling.</p>	
10	Switch on the ventilation unit and check the tightness of the whole device installed previously.	
11	Check that the manometer is working properly and that the transparent crystal tubes are correctly positioned: the indicated pressure drop must be positive but must not exceed the values indicated in chapter XV.2 Checking filters.	

VIII.8. Connection to the air network

For the air connection, select the duct sections according to the dimensions of the flexible sleeves, which must be correctly tensioned. The ducts must be insulated and the first accessories (elbows, tees, etc.) must be located at a distance of at least 2.5 times the diameter in order to avoid any disturbance (turbulence) of the airflow that could affect the proper functioning of the ventilation unit.

VIII.9. Motorised shutoff dampers (optional)

The unit can be equipped with external shutoff dampers.

If the system must be compliant with VDI6022 requirements and if the system shall be standstill, the ventilation system, of which this unit is a part, must be supplemented with additional dampers on the outdoor air and exhaust air side, in order to fulfil the requirements. These dampers must comply with at least tightness class 2 of EN 1751 and that they must be insulated (double-shell with intermediate insulated). This kind of damper is not available as an option.

VIII.10. Connection of power supply

It is necessary to provide protection devices (circuit breaker, differential) upstream of the ventilation unit's power supply cable.

The power supply cable is connected directly to the back of the isolator switch (A) placed on the side of the unit, near the extract air port. It is necessary to open the lower access door.

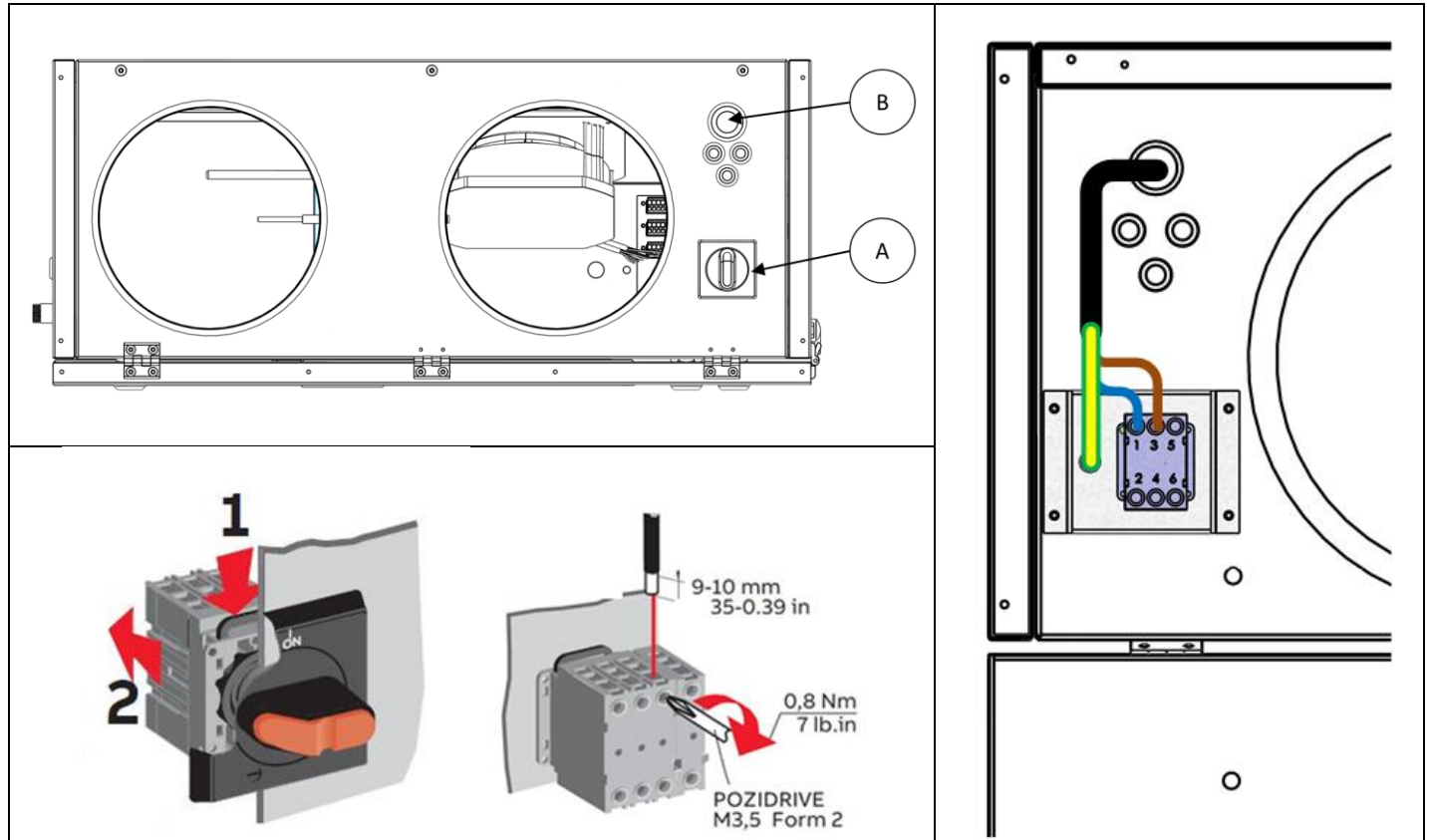

Drill a hole in the rubber grommet (B) and pass the power cable through it.

Connect power supply wires directly to the terminal block of the isolator switch (use crimped cable ends). The terminal block of the isolator switch can be unclipped to facilitate the wiring operation.

Connect the ground wire (PE) to the crimped nut clamp provided for this purpose (use a lug terminal for M6 screws). The ground wire (PE) should be slightly longer than the phases and neutral wires.

Securely attach and clamp the power cable to a fixed part (frame, cable tray, etc.).

IX. CONDENSATE EVACUATION

IX.1. Evacuation by gravity - general

As standard, the unit is designed for a gravity drain of condensate (without high points).

The installation of a siphon is to be expected at the time of installation of the unit:

- On the heat exchanger condensate tray,
- And on the CO / DXR coil condensate tray (if present).

	Non-compliance with the installation rules for condensate syphons can lead to the condensate tray overflowing and to internal flooding of the ventilation unit, which can result in damage to the equipment, malfunctions and danger to personnel.
--	--

See I.2 Weights and dimensional data for location and type of condensate discharge connection interface.

Provide a separate siphon on each condensate drain hose (plate heat exchanger condensate tray and CO/DXR coil condensate tray). The same siphon cannot be used for several drains.

IX.2. Plates heat exchanger siphon

	Non-compliance with the installation rules for condensate syphons can lead to the condensate tray overflowing and to internal flooding of the ventilation unit, which can result in damage to the equipment, malfunctions and danger to personnel.
--	--

To be functional, the siphon must always be filled with water from inside the unit. This must be filled during the first start-up of the unit, and it may bay necessary to manually re-fill after a period of shutdown or prolonged non-condensing operation.

Make sure that the siphon device is perfectly sealed with the connection tap provided in the unit in order to prevent any external air from being drawn in.

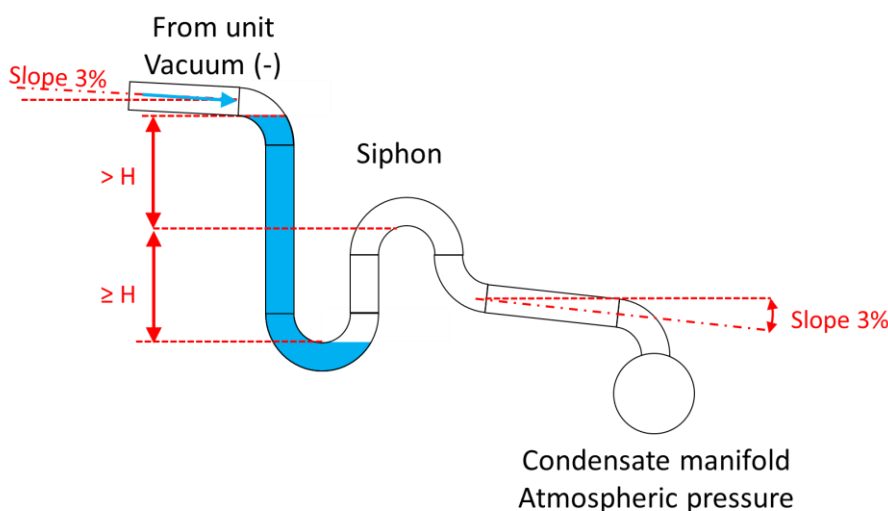

Vacuum (Pa)	H (mm)
100	10
200	20
300	30
400	40
500	50
600	60
700	70
800	80
900	90
1000	100
1100	110
1200	120
1300	130
1400	140
1500	150

The height H depends on the maximum vacuum. If there are no space constraints, a height of H = 120mm can be used for all applications. The installation of a syphon with an integrated non-return device (ball, spout, damper, etc.) means that this minimum height constraint is not necessary. Ensure that there is a 2-3% gradient towards the condensate drain to drain off the condensate and that the collector is neither under- nor over-pressurised.

IX.3. Remote coil siphon



Non-compliance with the installation rules for condensate syphons can lead to the condensate tray overflowing and to internal flooding of the ventilation unit, which can result in damage to the equipment, malfunctions and danger to personnel.

The requirements of the chapter IX.2 Plates heat exchanger siphon apply. Unlike the condensate drain of the plate heat exchanger, which is under low pressure relative to atmospheric pressure, the condensate drain of the remote coil is under overpressure relative to atmospheric air pressure, which requires a different siphon height.

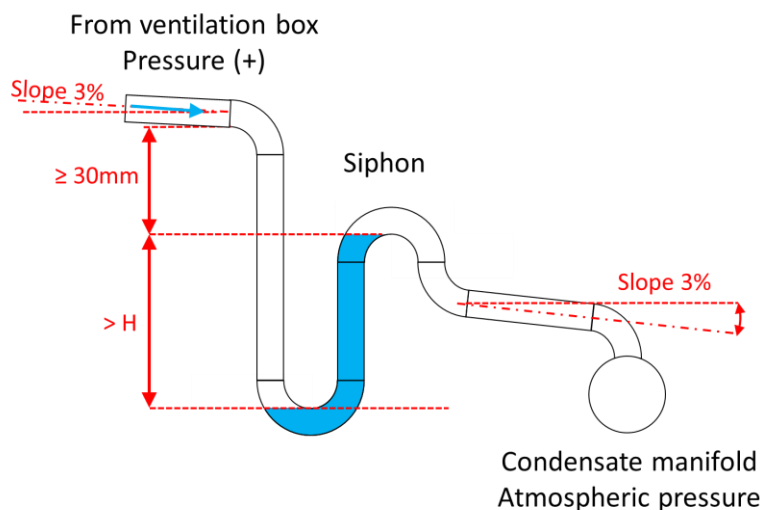

Pressure (Pa)	H (mm)
100	10
200	20
300	30
400	40
500	50
600	60
700	70
800	80
900	90
1000	100
1100	110
1200	120
1300	130
1400	140
1500	150

The height H depends on the maximum downstream pressure of the coil (condensate tray). If there are no space constraints, a height of H = 120mm can be used for all applications.

Ensure that there is a 2-3% gradient towards the condensate drain to drain off the condensate. Make sure that the collector is neither under- nor over-pressurised.

IX.4. CO or DXR Coils condensate siphon

IX.4.a. FLATPOWER 600...900

CO or DXR Coils being located downstream the supply air fan, the connection must meet the same requirements as for the installation of a remote coil siphon (see IX.3 Remote coil siphon).

IX.4.b. FLATPOWER 1300...2500

CO or DXR Coils being located upstream the supply air fan, the connection must meet the same requirements as for the installation of a plate heat exchanger siphon (see IX.2 Plates heat exchanger siphon).

IX.5. Condensate evacuation with condensate lift pump (optional)

IX.5.a. General information

If condensate drainage by gravity is not possible, a condensate lift pump with mounting accessories is available as an optional kit. The condensate lift pump makes it possible to evacuate the condensate at a higher level from the unit (for example on the roof, in another room...) or in case of high point on the evacuation line. The operation of the pump does not affect acoustic qualities of the unit.



Non-compliance with the installation rules of the condensate siphon can lead to an overflow of the condensate pan and an internal flooding of the unit that can cause damages to the equipment, damages, malfunctions, and endanger the occupants and staff.

IX.5.b. Overview of the condensate lift pump kit

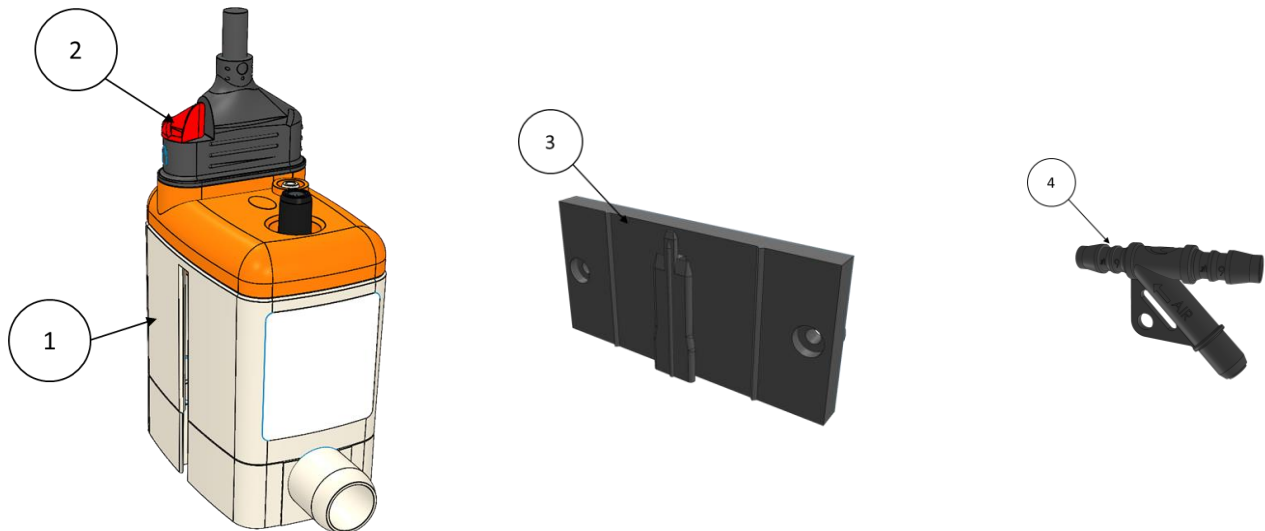

Mark	Description
1	Pump
2	Electrical cable with lockable connector
3	Mounting bracket
4	Anti-siphoning device
–	Fixing screws (x2)
–	Transparent PVC tube (length 5m to cut)
–	Clamp

IX.5.c. Operating principle

The pump operates autonomously as soon as the unit is switched on. It is equipped with a level controller that automatically switches the pump on and off depending on the level of condensate in the condensate tray.

As standard, the pump incorporates a NC (Normally Closed) dry contact level switch (LS1 / LS2) that opens when the condensate level contained in the condensate tray reaches a critical level, see XVII WIRING DIAGRAMS. This contact is used in order to control the operation of the ventilation unit in the event of abnormally high condensate level and thus protects the equipment, as well as the occupants and the staff.

IX.5.d. Maintenance

The condensate lift pump requires regular cleaning with bleach in order to maintain the correct operation of the internal valves and the level detection device. The frequency of cleaning should be adapted regarding the environment in which the unit operates.

Check the correct operating of the pump every maintenance operation. Check absence of suspicious noise on the pump by forcing its operation in filling condensate pan with clean water. Check the condition of the suction and discharge tubes and their connections.

IX.5.e. Performances and operating limits

Maximal length	10m
Maximum elevation	5m
Condensate maximum temperature	+35°C
Overheating thermal protection (automatic reset)	+115°C
Overflow dry contact (LS1 / LS2) protection	NC (Normally closed) 8A resistive – 250Vac
Power input	14W

X. ELECTRICAL CONNECTION OF EXTERNAL DEVICES

X.1. Remote control of low-speed forced operation (reduced operation)

The external low speed forced operation command allows the unit to be forced to operate at low speed, regardless of the current operating mode requested by the time schedule.

The external control has priority over the time schedule. If the central ventilation unit is switched off by the time schedule, the activation of the external forced low-speed control (reduced operation) will force the central unit to start up at low speed.

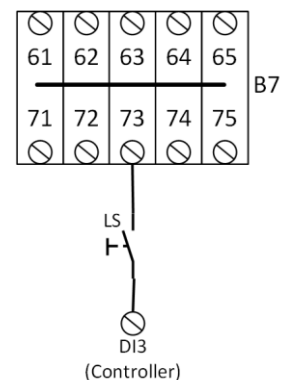

X.2. Remote control of high-speed forced operation (normal operation)

The external high-speed forced operation command (normal operation) forces the ventilation speed of the central ventilation unit to high speed, regardless of the operating speed requested by the time schedule and regardless of the status of the external low-speed forced operation command.

The external high-speed forced operation command (normal operation) has priority over the time schedule and the external low-speed forced operation command (reduced operation).

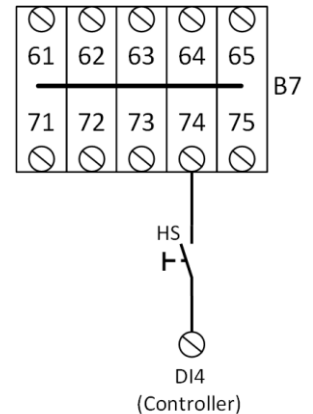

X.3. Remote stop control

The external shutdown control forces the central ventilation unit to shut down, regardless of the operating mode requested by the time schedule and regardless of the status of the external forced operation commands for reduced or normal operation.

The use of shutdown dampers on the supply and extract air networks is highly recommended in case of repeated starting and stopping of the ventilation unit.

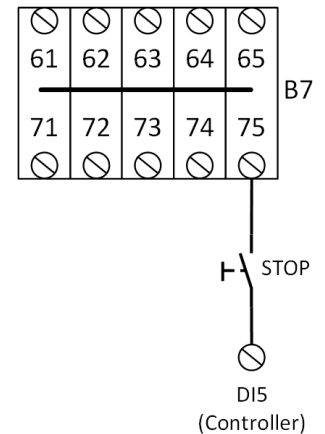

X.4. Remote fire protection control

When the external fire protection control is activated, the central ventilation unit operates in fire protection mode, regardless of the operating mode requested by the time schedule and regardless of the status of the external forced operation controls for reduced or normal operation. The fire protection mode has priority over all other operating modes.

The operation of the machine depends on the function settings made by the user. By default, the function is inactive when the equipment leaves the factory.

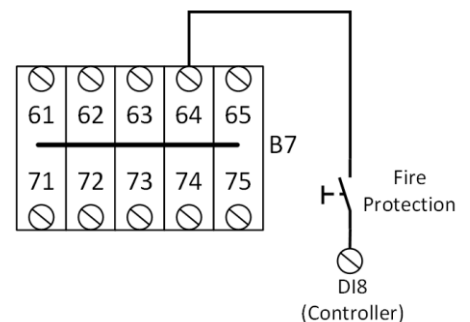

X.5. Control of supply shutoff damper - RMS

The supply shutoff damper can be provided as an option. It is powered directly from the controller's DO1 output (24V AC). It has a safety return spring that ensures the register closes in the event of a power failure.

Installation and electrical connection are the responsibility of the installer.

The use of shutoff dampers on the supply and extract air networks is highly recommended in case of repeated starting and stopping of the ventilation unit.

When the ventilation unit is in operation, there is a voltage of 24V AC between terminals (32) of terminal block B3 and (DO1) of controller. When idle, there is no voltage.

If the system must be compliant with VDI6022 requirements and if the system shall be standstill, the ventilation system, of which this unit is a part, must be supplemented with additional dampers on the outdoor air and exhaust air side, in order to fulfil the requirements. These dampers must comply with at least tightness class 2 of EN 1751 and that they must be insulated (double-shell with intermediate insulated). This kind of damper is not available as an option.

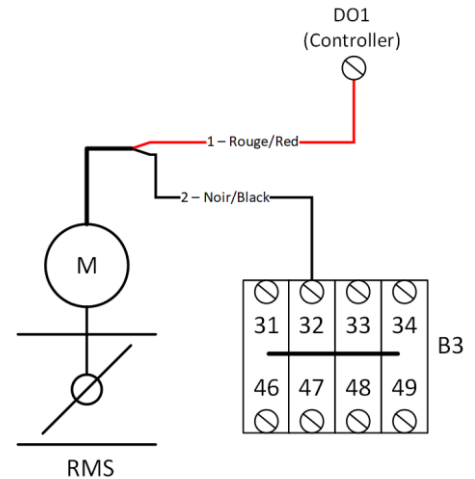

X.6. Control of extract shutoff damper - RMR

The supply shutoff damper can be provided as an option. It is powered directly from the controller's DO2 output (24V AC). It has a safety return spring that ensures the register closes in the event of a power failure.

Installation and electrical connection are the responsibility of the installer.

The use of shutoff dampers on the supply and extract air networks is highly recommended in case of repeated starting and stopping of the ventilation unit.

When the ventilation unit is in operation, there is a voltage of 24V AC between terminals (31) of terminal block B3 and (DO2) of controller. When idle, there is no voltage.

If the system must be compliant with VDI6022 requirements and if the system shall be standstill, the ventilation system, of which this unit is a part, must be supplemented with additional dampers on the outdoor air and exhaust air side, in order to fulfil the requirements. These dampers must comply with at least tightness class 2 of EN 1751 and that they must be insulated (double-shell with intermediate insulated). This kind of damper is not available as an option.

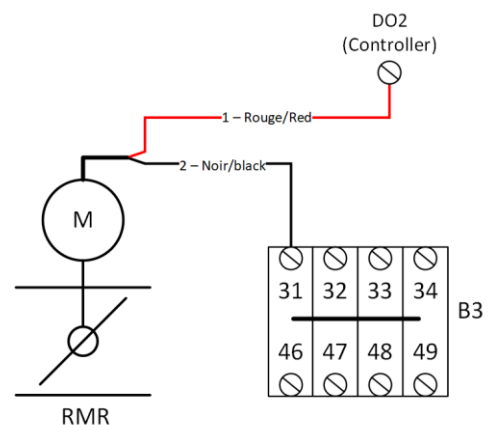

X.7. Night overventilation (Night cooling) signal (LOBBY version)

The night cooling function takes advantage of the cooler outside temperatures at night to lower the internal temperature of the building and thus improve daytime comfort while limiting the energy consumption of any cooling systems. When the function is active, the aim is to maximise the airflow to make the most of the free cooling energy available outside. For this function to be fully functional when the fans are regulated at constant pressure (LOBBY), it is necessary to be able to force the opening of the registers in the network, otherwise the air volume will be limited to an average value. A 24V AC output (to be relayed) is provided between the terminals (47) of the terminal block B3 and (DO7) of the controller to force the opening of the zone registers during the night cooling period. When the function is active, there is a voltage of 24V AC between terminal (47) of the terminal block B3 and (DO7) of the controller. When idle, there is no voltage.

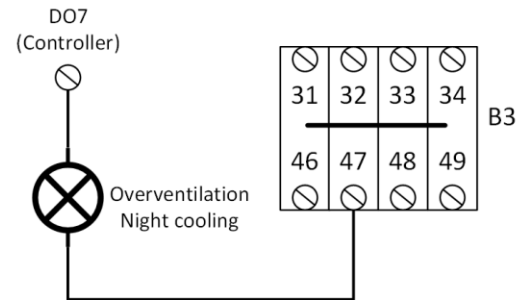

X.8. Alarm output signal

The output contact is polarised at 24V AC and is programmed as NO (Normally Open) at the factory:

No alarm or class C alarm (warning) (See alarm table)	Class A or B alarm is active (See alarm table)
No voltage between terminal (47) of the terminal block B3 and (DO5) of the controller	24V AC between terminal (47) of the terminal block B3 and (DO5) of the controller

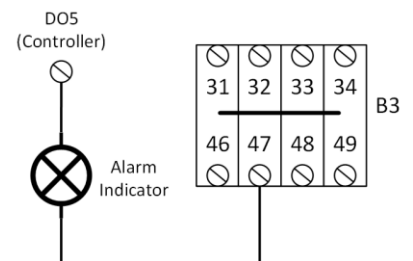

The alarm signal is limited to 100mA. Under no circumstances should it be used to supply a consumer directly. The signal must be relayed.

X.9. Remote firefighter stop - ADP

The dry NC (Normally Closed) contact of the ADP must be connected by the installer between terminal (12) and (13) of the terminal block B2 after having removed the shunt installed at the factory.

Opening the circuit cuts off the general 24V AC power supply to the entire control unit. The ventilation unit is immediately stopped and the shutoff dampers (if present) are closed by their automatic return spring.

The unit restarts automatically as soon as the circuit is closed (closing of the ADP contact). If an ADP is installed, a shutoff damper with a safety return spring should be fitted downstream of the supply air filters.

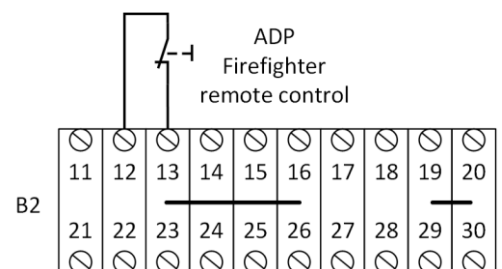

X.10. Autonomous trigger detector – DAD

The dry NC (normally closed) contact of the DAD must be connected by the installer between terminals (83) and (84) of the terminal block B10 after having removed the shunt installed at the factory.

Opening the circuit cuts off the general 24V AC power supply to the entire control unit. The ventilation unit is immediately stopped, and the shutoff dumpers (if present) are closed by their automatic return spring.

The unit restarts automatically as soon as the circuit is closed (closing of the DAD contact). If a DAD is installed, a shutoff dumper with a safety return spring should be fitted downstream of the intake air filters.

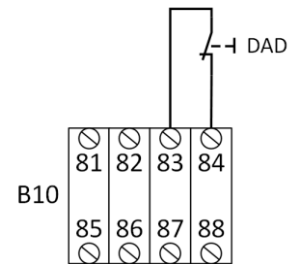

X.11. Heat exchanger condensate lift pump (PRC)

Connect the power supply:

- Blue wire (neutral) on terminal (1) of the terminal block B1,
- Brown wire (Phase) on terminal (2) of the terminal block B1.

Remove the shunt between terminals (81) and (82) of the terminal block B10.

Connect the level switch LS1:

- Black wire on terminal (81) of the terminal block B10
- Grey wire on terminal (82) of the terminal block B10.

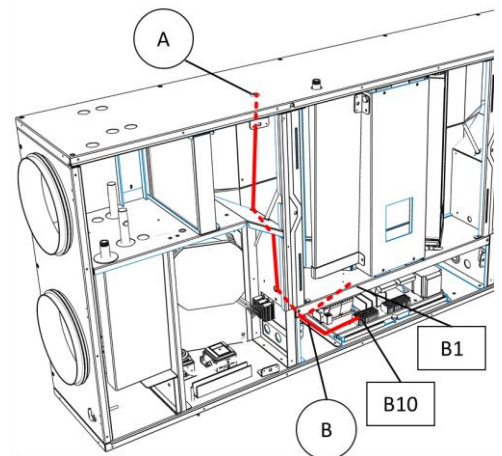
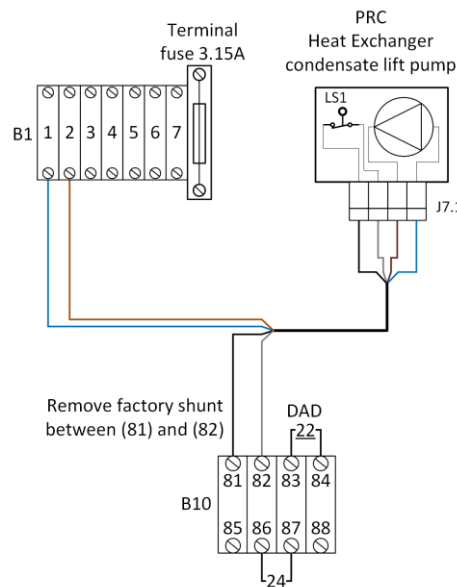

A grommet (A) is provided at the front of the unit to run the electric cable that connects the electrical board (terminal block B1 and B10) to the lift pump. Leave enough overlength in zone (B) to maintain mobility with the sliding electric board.

Note: the cable provided with the optional condensate lift pump need to be extended on the FLATPOWER 2500.

X.12. CO / DXR coils condensate lift pump (PRC)

Connect the power supply:

- Blue wire (neutral) on terminal (1) of the terminal block B1
- Brown wire (Phase) on terminal (2) of the terminal block B1.

Remove the shunt between terminals (86) and (87) of the terminal block B10.

Connect the level switch LS2:

- Black wire on terminal (86) of the terminal block B10
- Grey wire on terminal (87) of the terminal block B10.

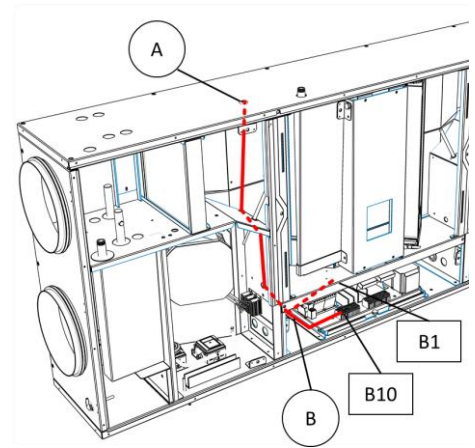
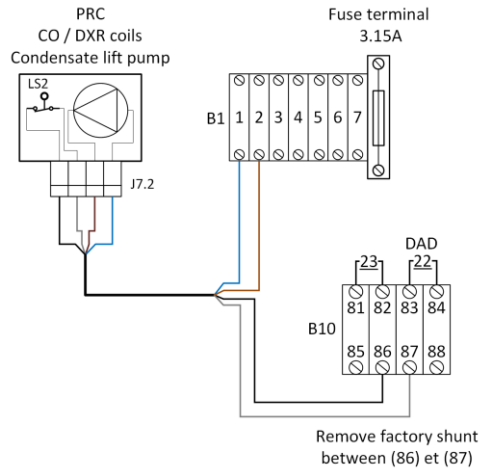

A grommet (A) is provided at the front of the unit to run the electric cable that connects the electrical board (terminal block B1 and B10) to the lift pump. Leave enough overlength in zone (B) to maintain mobility with the sliding electric board.

Note: the cable provided with the optional condensate lift pump need to be extended on the FLATPOWER 2500.

XI. INTEGRATED CO/DXR COILS CONNECTION

The integrated CO coil can be used for heating only, cooling only, or changeover.

The connections to be respected (3-way valve and circulator) are the same as for the coils installed in the duct (see XII CONNECTION OF REMOTE COILS IN DUCT) with the difference that it is not necessary to move the supply air temperature sensor SSG.

The integrated reversible direct expansion coil can be used for heating only, cooling only, or heating/cooling by reverse cycle (i.e., reversible heat pump).

The management of a DXR coil is presented in a dedicated sheet independent of this manual. Please contact your distributor.

Provide a gravity condensate drain or the installation of a condensate lift pump available as an optional kit in the event of cool production.

XII. CONNECTION OF REMOTE COILS IN DUCT

The entire FLATPOWER range can be combined with the COMBI BOX range in order to extend the basic functionality, particularly in cases where remote cooling coils are to be added to the duct system.

XII.1. Remote hot water coil

When a duct-mounted hot water coil (available as an option in Combi Box) is used, the following accessories must be connected:

- 3-way valve (available as an option)
- The THA frost protection thermostat (available as an option)
- The pump (circulator) for the irrigation of the coil (selection and supply the responsibility of the installer).

It is also necessary to move the ventilation supply air temperature sensor (SSG) downstream of the remote hot water coil (see XII.6 Offset of the supply air temperature sensor).

The installation must comply with the following hydraulic connection principle:

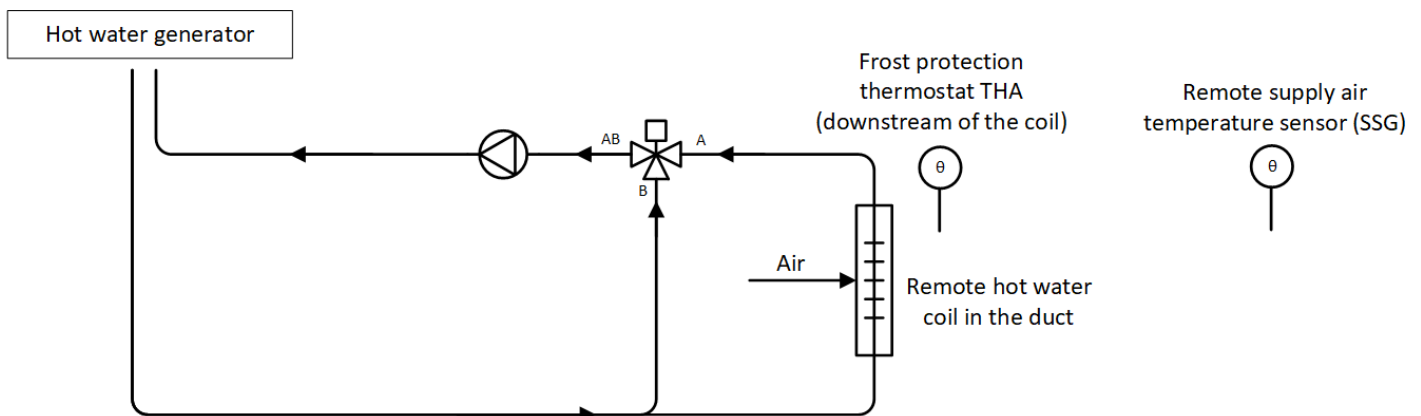

The hydraulic connection and installation of the hot 3-way valve must meet the following requirements:

<p>Observe the direction of the valve axis</p>	<div style="border: 1px solid black; padding: 5px; width: fit-content; margin-left: auto; margin-right: auto;"> <p>The axis of the valve must not be oriented upside down</p> </div>
<p>Observe the flow direction of the fluid</p>	

The electrical connection must meet the following requirements:

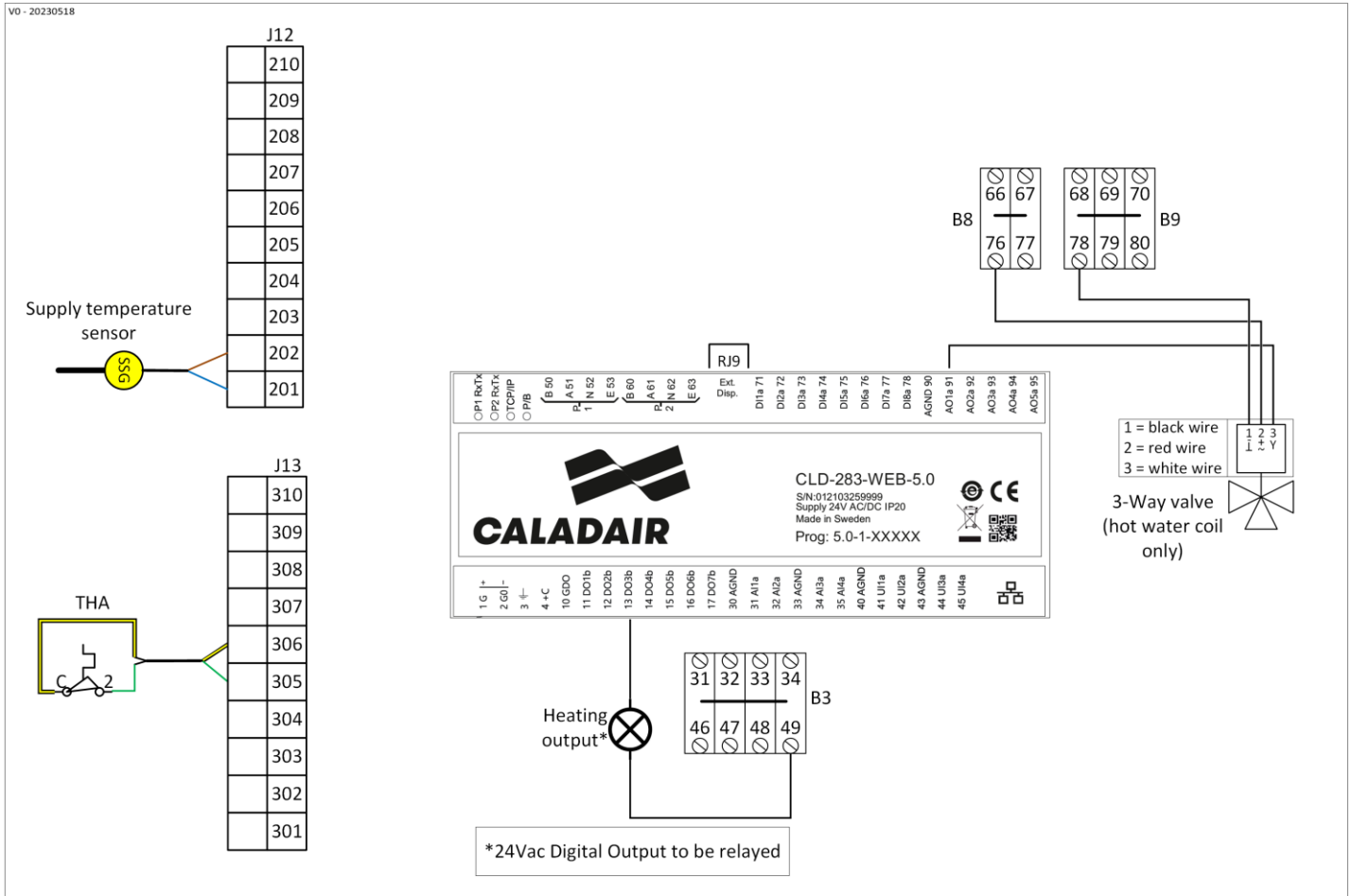

The frost protection thermostat THA is of the NC (normally closed) type. It should be set to +5°C. It is closed when the bulb temperature is above +5°C and opens when the temperature drops below +5°C. Its function is to protect the coil from freezing. When the contact opens, the controller stops the ventilation. When the temperature rises, the controller restarts the fans. As long as the contact is open, the controller displays the alarm (56). This alarm is stored in the alarm history and is automatically acknowledged when the contact closes.

Please note that the “heating mode” signal is a control signal and not a power signal. Therefore, it must not be used as a power supply and must be relayed. The signal sent by the controller is 24V AC (100mA max).

XII.2. Remote cold water coil

When a remote cold water coil (available as an option in COMBI BOX) is used, it is necessary to connect the 3-way valve (available as an option) to the controller of the ventilation unit.

Provide a gravity condensate drain or the installation of a condensate lift pump available as an optional kit.

The coil circulator is the responsibility of the installer.

It is also necessary to move the supply air temperature sensor (SSG) downstream of the remote cold water coil (see XII.6 Offset of the supply air temperature sensor).

FLATPOWER

Ceiling Energy Recovery Unit

The installation must comply with the following hydraulic connection:

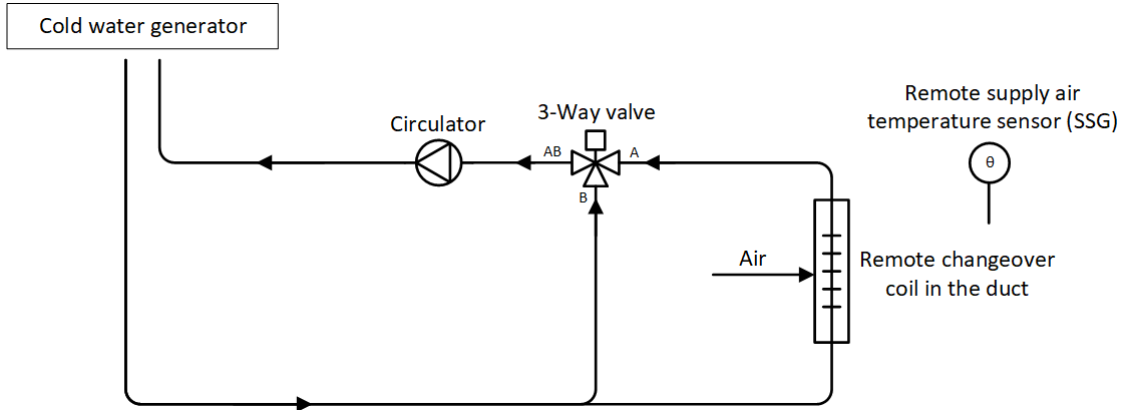

The hydraulic connection and installation of the 3-way valve must meet the following requirements:

<p>Observe the direction of the valve axis</p>	<p>The axis of the valve must not be oriented upside down</p>
<p>Observe the flow direction of the fluid</p>	

The electrical connection must meet the following requirements:

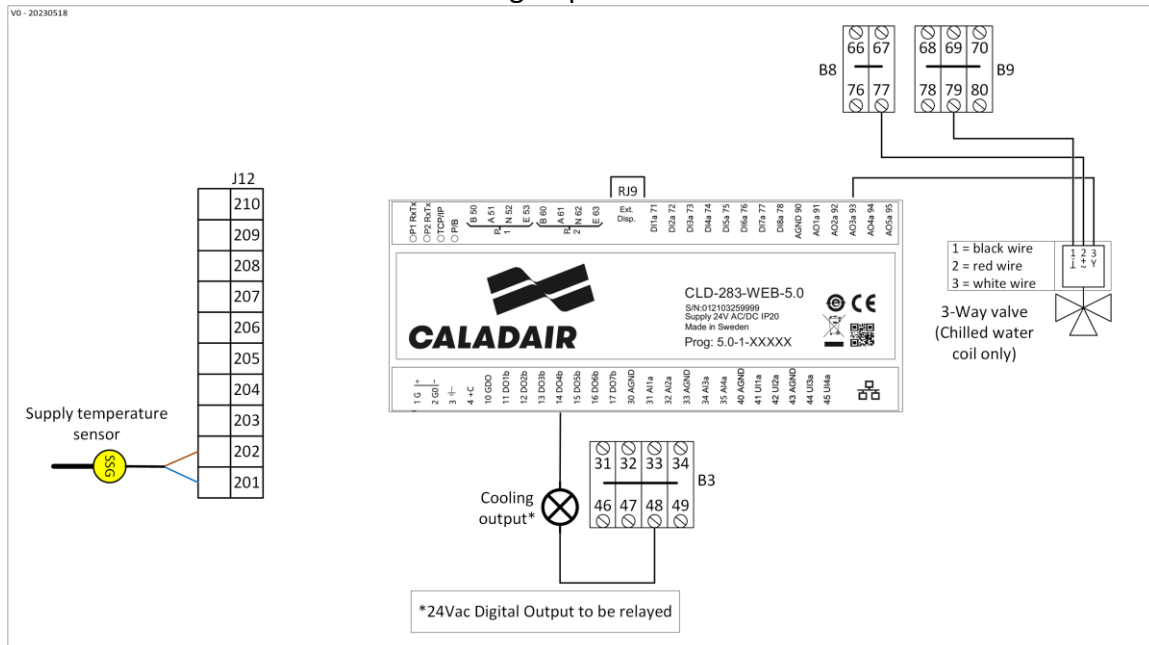

Please note that the "cooling mode" signal is a control signal and not a power signal. Therefore, it must not be used as a power supply and must be relayed. The signal sent by the controller is 24V AC (100mA max).

XII.3. Remote changeover coil

When a remote changeover coil (available as an option in Combi Box) is used, it is necessary to connect the 3-way valve (available as an option) and the changeover thermostat to the controller of the ventilation unit.

Provide a gravity condensate drain or the installation of a condensate lift pump available as an optional kit.

The changeover coil circulator is the responsibility of the installer.

It is also necessary to move the supply air temperature sensor (SSG) downstream of the remote changeover coil (see XII.6 Offset of the supply air temperature sensor).

The changeover thermostat allows the control of 3-way valve to be reversed depending on the temperature of the fluid measured at CO coil inlet. It should be installed in the water supply line of the CO coil, upstream of the 3-way valve.

The installation must comply with the following hydraulic connection:

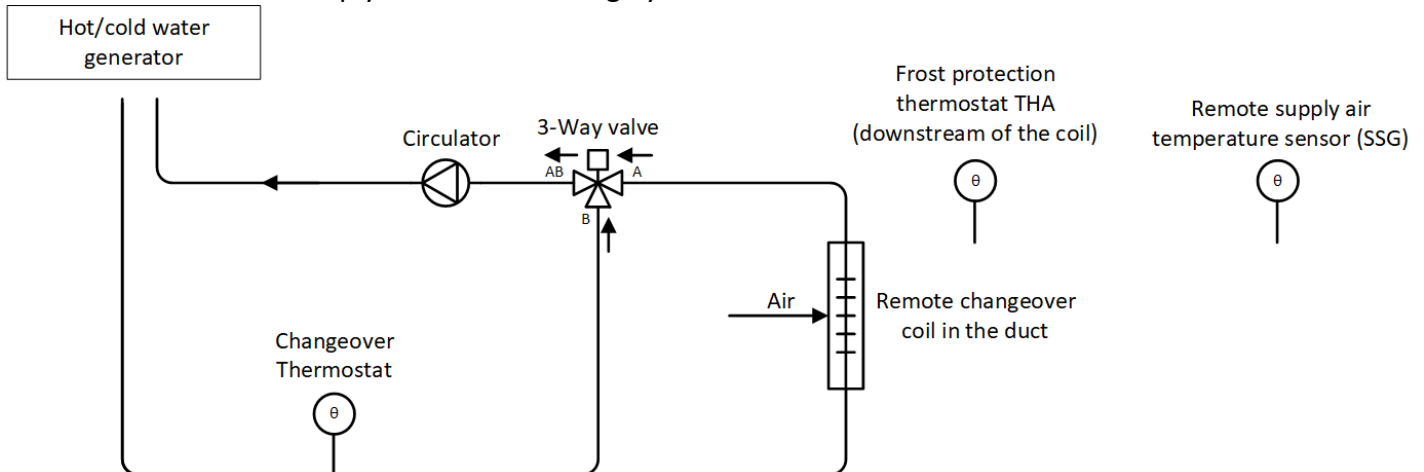

Electrical connection of the 3-way valve actuator to the changeover thermostat

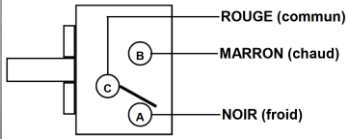
Changeover thermostat side		Terminal block and actuator side	
 	Red wire	Y (actuator control signal)	
	Brown wire	AO1 controller (heating signal)	
	Black wire	AO3 controller (colling signal)	

The electrical connection must meet the following requirements:

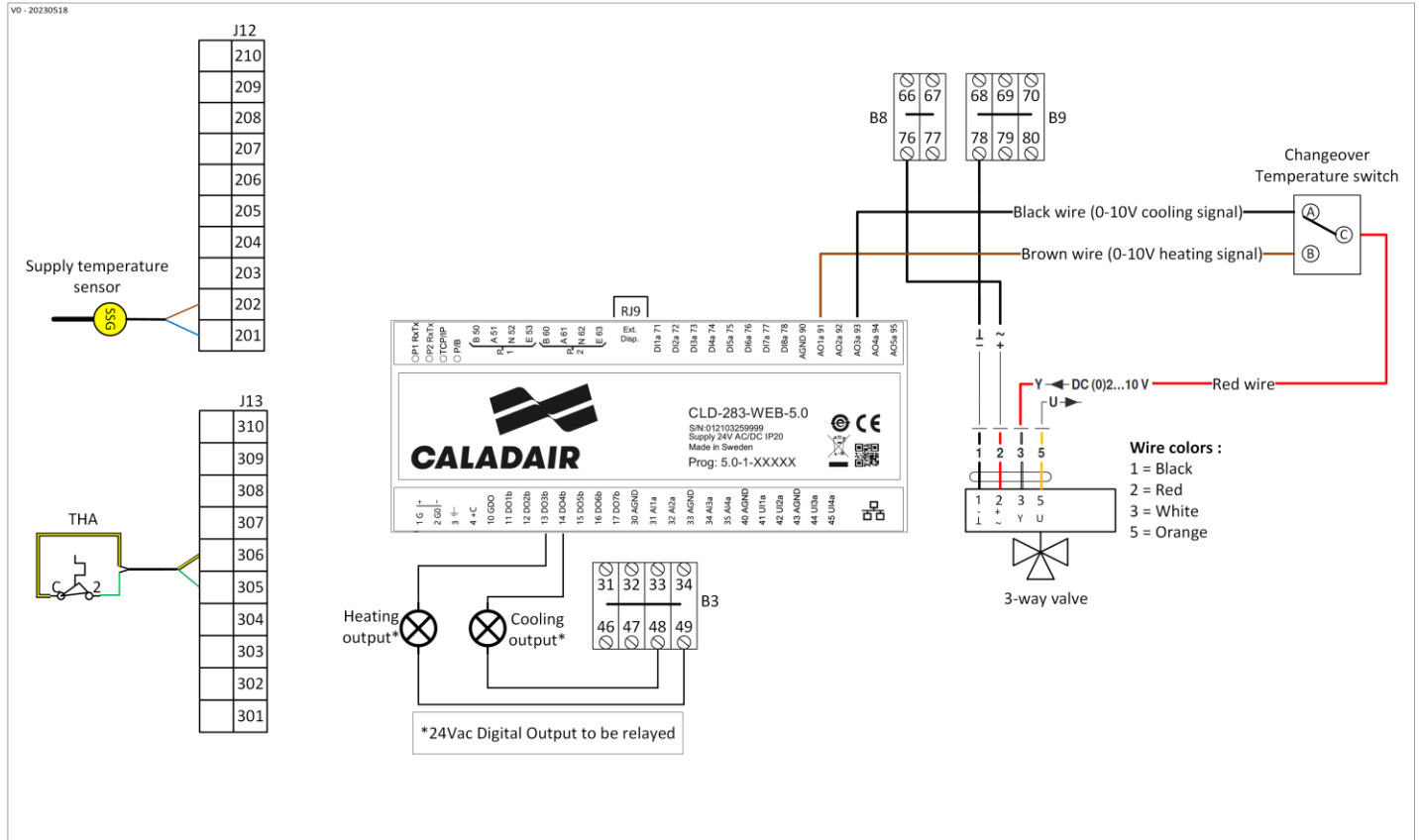

The behaviour of the changeover thermostat is defined in the table below:

$T \geq 30^{\circ}\text{C} \pm 4^{\circ}\text{C}$	$T \leq 15^{\circ}\text{C} \pm 4^{\circ}\text{C}$
Contact C-A open (C-B closed)	Contact C-A closed (C-B open)

Please note that the “cooling mode” and “heating mode” signals are control signals and not power signals. Therefore, they must not be used as a power supply and must be relayed. The signal sent by the controller is 24V AC (100mA max).

XII.4. Remote serial hot water + cold water coils

Does not manage dehumidification.

Provide a gravity condensate drain or the installation of a condensate lift pump available as an optional kit for the cold water coil.

Install the frost protection thermostat THA (bulb) downstream of the hot water coil.

Please refer to the connection requirements of remote hot and cold water coils in duct, see XII.1 Remote hot water coil et XII.2 Remote cold water .

FLATPOWER

Ceiling Energy Recovery Unit

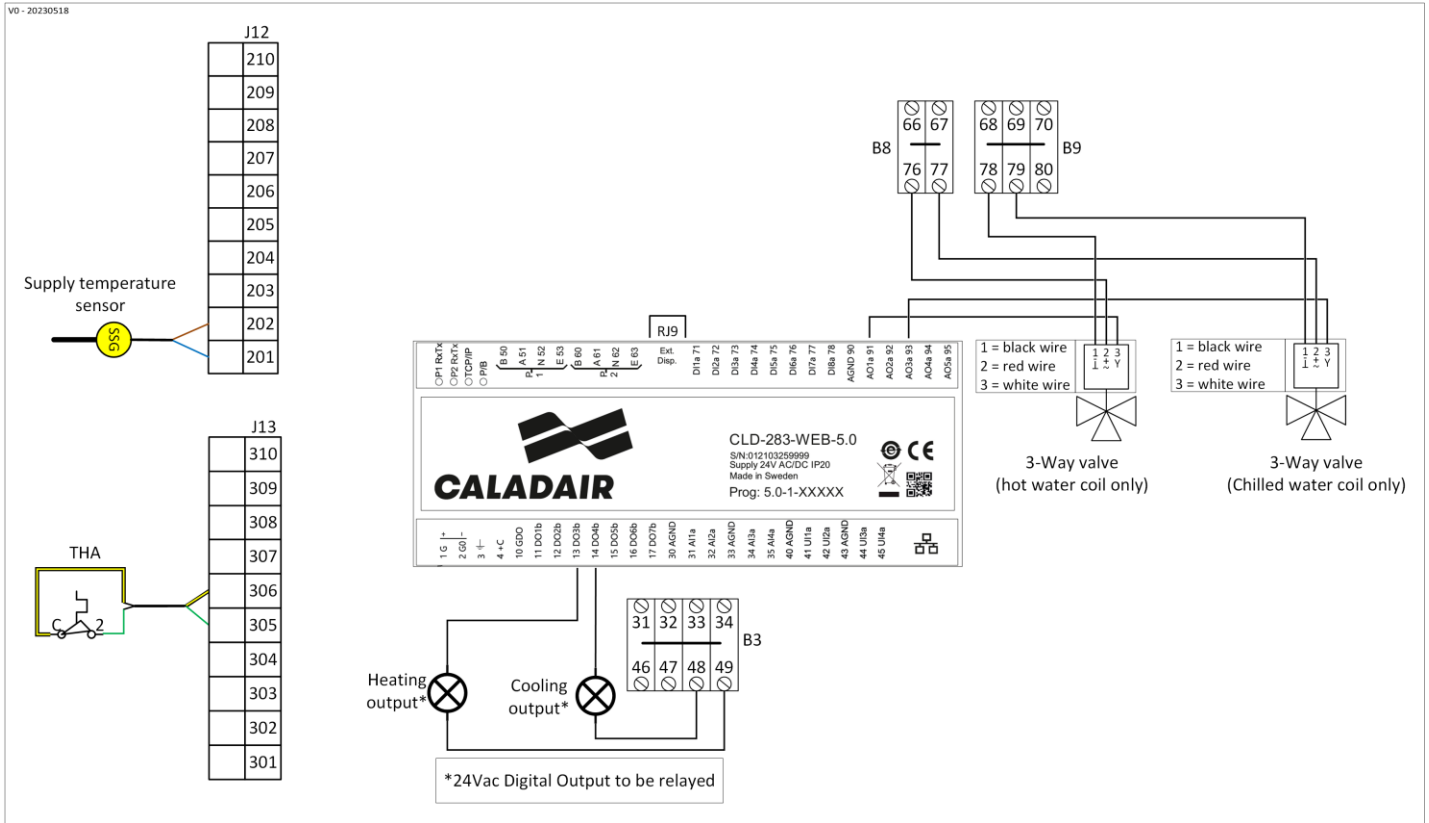

XII.5. Remote reversible direct expansion (DXR) coil

The control of a reversible direct expansion (DXR) coil is described in a separate document and is independent of this manual. Please contact your supplier.

Provide a gravity condensate drain or the installation of a condensate lift pump available as an optional kit in case of cold production.

XII.6. Offset of the supply air temperature sensor SSG

A grommet (A) is provided in front of the unit to facilitate the routing of the sensor cable between outside the unit and the electric board.

Prefer the installation of a new temperature sensor equipped with a 4m length cable.

If the sensor cable needs to be extended, take care to use a connector with low contact resistance so as not to disturb measurement signal. Use a conductor section of at least 0.5mm².

Route the cable in place of the original temperature sensor cable. The original temperature sensor can be left in place in order to maintain the seal on the wall which separates the 2 compartments.

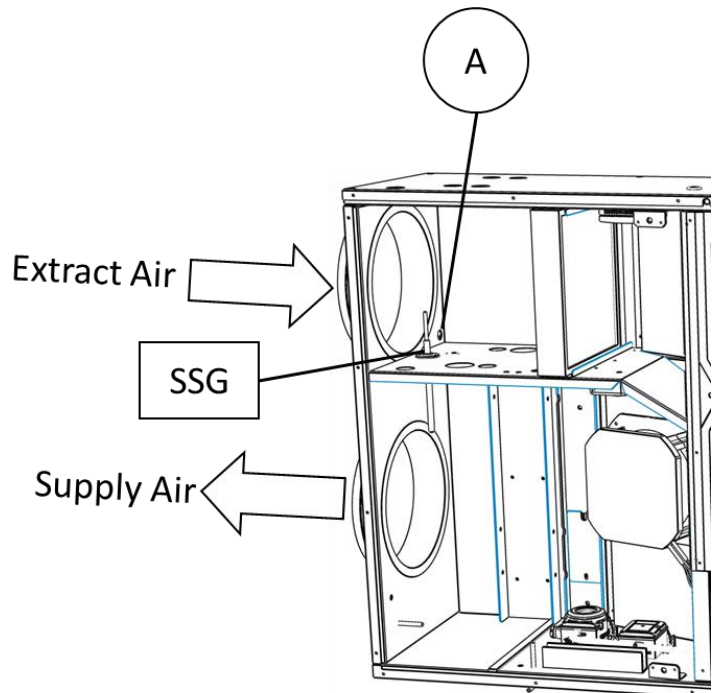

XIII. GENERAL OPERATION

XIII.1. Thermal sequence initialisation

Initialisation at start-up allows the unit to be started at an operating point that is as close as possible to the one that will be recalculated during operation in order to avoid any source of discomfort and unnecessary energy consumption.

The initialisation of the thermal sequence at start-up depends on the outdoor temperature measured at the time the machine is started:

Outdoor temperature < +3°C	Outdoor temperature ≥ +3°C
<p>The unit starts at 100% heat load*.</p> <p>As long as the feedback signal of the supply air fan is idle**, the electric heating coil is not activated.</p>	<p>La centrale démarre en récupération d'énergie maximale.</p>

*The control output of the 3-way valve or the control output of the electric heating coil is at 100% (10V).

**ECO/DIVA: the DEP S pressure switch contact is open; LOBBY: the pressure signal is below the minimum threshold; MAC2/QUATTRO: the volume signal is below the minimum threshold

XIII.2. Start up sequence

The start-up sequence is activated when the following conditions are met:

- The unit is ON
- There are no active class A alarms (alarms that shut down the unit) or the external control is not active
- At least one time programme (reduced operation or normal operation) is active, or a forced operation (normal operation or reduced operation) is active, or the fire protection function set to start the unit is active, or there is a request for operation from the BMS.

The start-up sequence takes a total of 120 seconds. During this time, the alarms are disabled (except for the THS electric coil overheating alarm (63), which is monitored during this period) and the AHU starts up at the operating point defined at the initialisation of the thermal sequences at start-up. The minimum fan control signal does not apply.

The shutoff dampers open as soon as the start sequence is activated. The control signal for the extract fan is enabled 15 seconds after the start sequence is activated. 15 seconds later, the control signal for the extract air fan is enabled and the extract air fan starts. The outputs for controlling the 3-way valves and the heating or cooling pumps are activated.

Once the 120 seconds have elapsed, the fan unit switches to normal mode at the end of the start-up sequence. The minimum and maximum fan control signal is then taken into account and the alarm monitoring function is activated.

In the event of a power failure, the unit will automatically restart as soon as the power supply is restored.

XIII.3. Shutdown sequence (post-ventilation)











The shutdown sequence occurs when at least one of the following conditions is met:

- Appearance of an alarm whose action requires the normal shutdown of the unit (note that some alarms are programmed for rapid shutdown, in which case the shutdown sequence is ignored and the unit shuts down immediately);
- The unit is switched to OFF;
- No active time range;
- The fire protection function is set to stop the unit;
- Stop request from the BMS.

The shutdown sequence lasts for a time related to the setting of the fan shutdown time limits (post-ventilation) and both the supply and extract shutoff dampers closing time limits. When the shutdown sequence is activated, the alarm management function and the electric coil output are immediately deactivated (the hot/cold water coil and heat exchanger outputs remain active). The supply air fan is switched off after 180 seconds. The extract air fan is switched off 30 seconds later. The supply and extract shutoff dampers are closed 5 seconds after the extract air fan has stopped and all actuator control signals are deactivated.

XIV. STARTING UP

The FLATPOWER ventilation unit come preset and ready to operate.
The commissioning procedure can follow the order of the following steps:

Step	Icon PG 5.0	Description	Additional information
1		Installation and electric wiring of options (if present)	
1.1		Heating/cooling 3-way-valve installation	See XI INTEGRATED CO/DXR COILS CONNECTION
1.2		Heating/cooling circulators installation	See XI INTEGRATED CO/DXR COILS CONNECTION
1.3		Thermostat CO, frost protection thermostat THA, supply air temperature sensor SSG, pressure tap LOBBY installation	See XI INTEGRATED CO/DXR COILS CONNECTION Voir VIII.6 Connection of the supply pressure tap (LOBBY)
1.4		External controls (ADP, DAD, low speed remote order, high speed remote order, stop remote order, fire protection) wiring	See X ELECTRICAL CONNECTION OF EXTERNAL DEVICES
1.5		Signal outputs (night cooling LOBBY, alarm indicator) wiring	See X ELECTRICAL CONNECTION OF EXTERNAL DEVICES
1.6		EDT2 remote room touch control wiring	See EDT2 manual See MS-CDF-020 - REGULATION EASY 5-0 manual
2		Controller date and time setting	See MS-CDF-020 - REGULATION EASY 5-0 manual
3		Automatic/manual daylight-saving setting	See MS-CDF-020 - REGULATION EASY 5-0 manual
4		Time schedules setting	See MS-CDF-020 - REGULATION EASY 5-0 manual
5		Fans setpoints setting	See MS-CDF-020 - REGULATION EASY 5-0 manual
6		Temperature setpoints setting	See MS-CDF-020 - REGULATION EASY 5-0 manual
7		Communication ports wiring and setting	See MS-CDF-020 - REGULATION EASY 5-0 manual
8		Specific functions setting	See MS-CDF-020 - REGULATION EASY 5-0 manual
8.1		Night cooling function	See MS-CDF-020 - REGULATION EASY 5-0 manual
8.2		Fire protection	See MS-CDF-020 - REGULATION EASY 5-0 manual
8.3		Frost prevention function by reducing supply airflow rate	See MS-CDF-020 - REGULATION EASY 5-0 manual
9		Checking the correct operation and PIDs adjustment	See MS-CDF-020 - REGULATION EASY 5-0 manual
10		Backup of user settings*	See MS-CDF-020 - REGULATION EASY 5-0 manual

*Using the backup function at the end of the commissioning will save all the adjusted parameters and will allow to restore a useful setup in any time.

XV. MAINTENANCE

XV.1. Annual general checking

Check the ducts, flexible sleeves and anti-vibration pads and replace them if necessary.
 Check that all the components connected to the control unit are in place so that no vibrations can be transferred to external items.
 Check the electrical connections and the tightness of the terminals.

XV.2. Checking filters

Classification		Cleaning* (water + gentle detergent)	Extraction* Supply*
Filtration efficiency ISO 16890	Reference		
ePM10 - 50%	M5	Restricted (1 à 4 times)	YES
ePM1 - 55%	F7	NO	

*Filter cleaning must be carried out with care to avoid damaging the filter media.

Only M5 filters can be blown out and cleaned with care.



When carrying out maintenance and checking/replacing filters, the fitted panels should be held and handled in such a way that the manometers do not discharge their liquid.

Frequency (in months of operation)	
Every 3 months (to be adapted according to local conditions)	Every 12 months
Checking (Cleaning if necessary for M5 filters)	Filters replacement

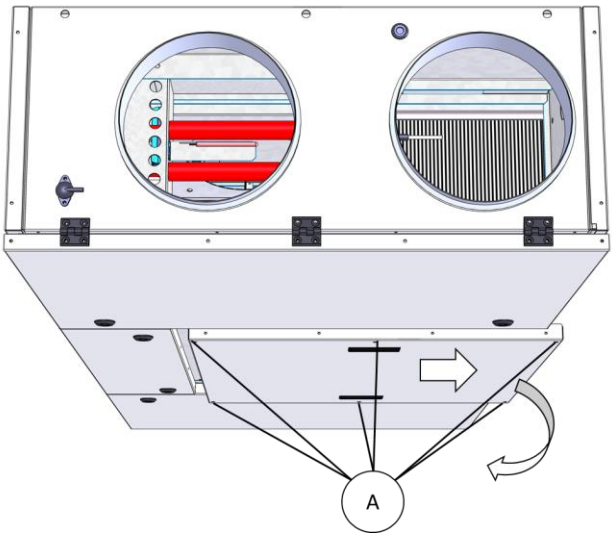
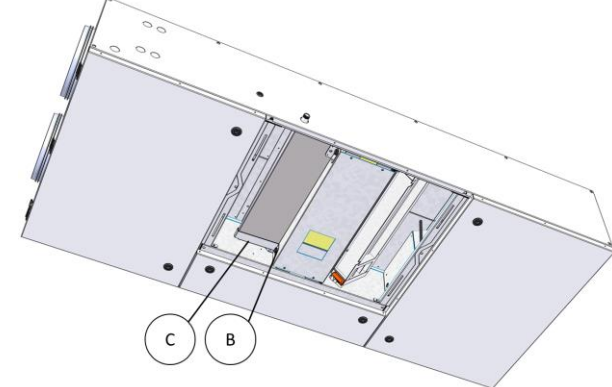
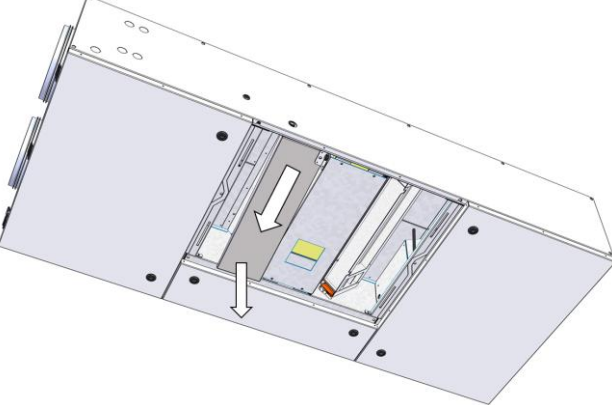

XV.3. Removal and refitting of the exchanger condensate tray

Step	Removal
D1	Stop the unit and cut off the power supply using the isolator switch on the side of the unit when the unit is in idle.
D2	Remove the draining condensate device connected to the condensate tray.

<p>D3</p>	<p>Remove the Poêlier* screws (A) placed on the perimeter of the lower access panel that features a restrain device then pull the panel forward about 3cm and tilt it.</p> <p>*A wide flathead screwdriver is needed.</p> <div data-bbox="194 577 858 707" style="border: 1px solid black; padding: 5px;">  <p>The weight of the lower access panel exceeds 25kg for the FLATPOWER 1800 and 2500 models.</p> </div>	
<p>D4</p>	<p>Remove the knurled heads screw (B) and the support tab (C) while supporting the tray.</p>	
<p>D5</p>	<p>Extract the condensate tray.</p>	
<p>Step</p>	<p>Refitting</p>	
<p>R1</p>	<p>Proceed in the reverse order to removal, taking care to ensure that the connection between the condensate drip tray and the siphon pipework is watertight.</p>	
<p>R2</p>	<p>Fill the condensate drip tray with water to fill the siphon (if gravity drain). Check the proper working of the condensate lift pump if present.</p>	
<p>R3</p>	<p>Start the machine. Check that there is no abnormal noise and that the performance and setpoints (pressure, volume flow, temperature, etc. depending on the version) are achieved.</p>	

The condensate tray can be cleaned and disinfected by soaking and rinsing with clean water, if necessary, with bleach.

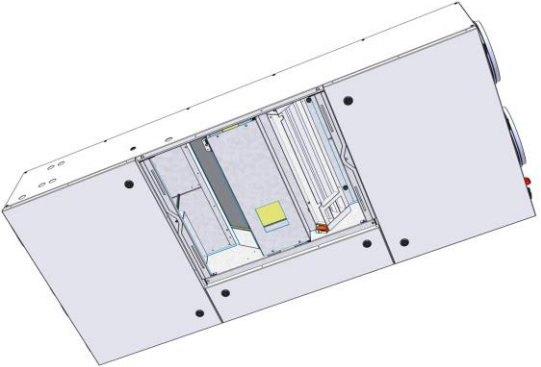
XV.4. Removal and refitting of the heat exchanger

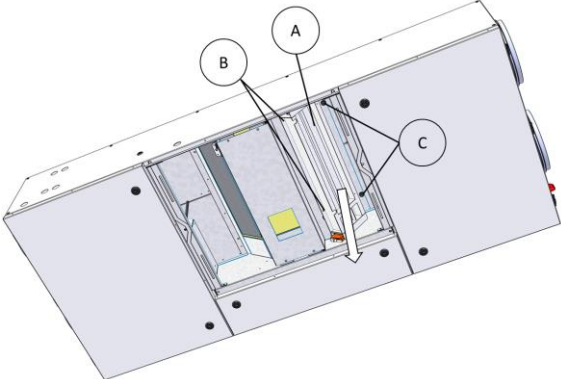
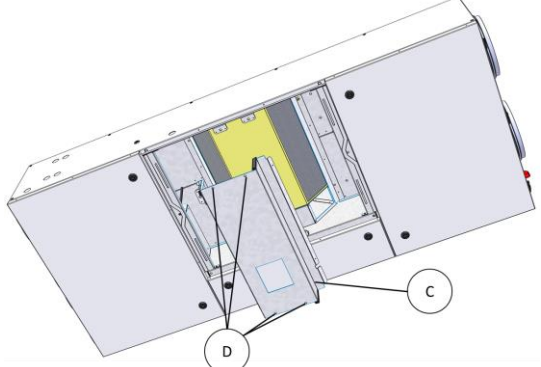
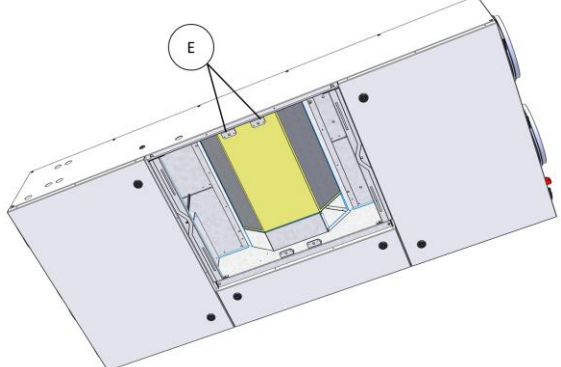
Step	Removal	
D1	<p>Remove the condensate tray (see XV.3 Removal and refitting of the exchanger condensate tray).</p> <p>Note: the unit must have been shut down by the HMI on/off button and the post-ventilation sequence fully finalized before the power supply is switched off so that the bypass damper is in its idle position. This ensures correct indexing between the shaft of the damper actuator and the shaft of the bypass damper during the refitting operation (see refitting step R2).</p>	
D2	<p>Remove the lower fixing screws (B). Then remove the upper knurled screws (C) and extract the bypass damper from its housing.</p> <div data-bbox="231 1021 895 1151" style="border: 1px solid black; padding: 5px;">  <p>The bypass damper is no longer held in position. A holding device may be required.</p> </div>	
D3	<p>Remove the base (C) by removing the Poëlier fixing screws (D).</p> <p>*A wide flathead screwdriver is needed.</p>	
D4	<p>Remove the support brackets (E).</p>	

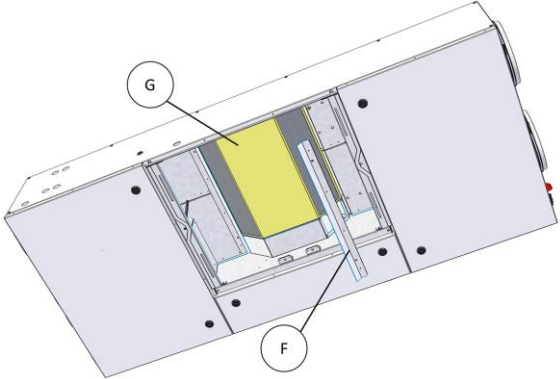
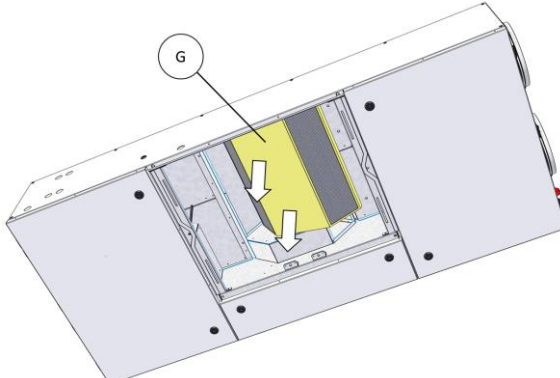
<p>D5</p>	<p>Remove the holding bracket (E) of the heat exchanger (G) supporting it.</p> <div style="border: 1px solid black; padding: 5px; margin-top: 10px;">  <p>The heat exchanger is no longer held in position. A holding device may be required. The maximum weight of the heat exchanger is less than 20kg for all the units.</p> </div>	
<p>D6</p>	<p>Remove the heat exchanger (G) by rotating it and sliding down.</p>	
<p>Step</p>	<p>Refitting</p>	
<p>R1</p>	<p>Proceed in reverse order to removal. Check for the integrity of seals on various parts removed and around the heat exchanger housing. Replace any defective seals.</p>	
<p>R2</p>	<p>Note 1: Replace the actuator on the shaft of the bypass damper respecting the angular indexing and the orientation of the actuator. Close the bypass damper by turning the shaft clockwise (the larger blades are now closed) until it stops. Check that the actuator is in closed position (shaft at clockwise stop), and slide it into the bypass damper shaft. If the actuator is not correctly fitted to the damper, the energy recovery system will not work properly and the unit will be noticeably uncomfortable.</p> <p>Note 2 : Observe the direction of the base: the base (E) must be located on the access door side of the control compartment.</p>	
<p>R3</p>	<p>Refit the condensate tray (see XV.3 Removal and refitting of the exchanger condensate tray).</p>	
<p>R4</p>	<p>Start the machine. Check that there is no abnormal noise and that the performance and setpoints (pressure, volume flow, temperature, etc. depending on the version) are achieved.</p>	

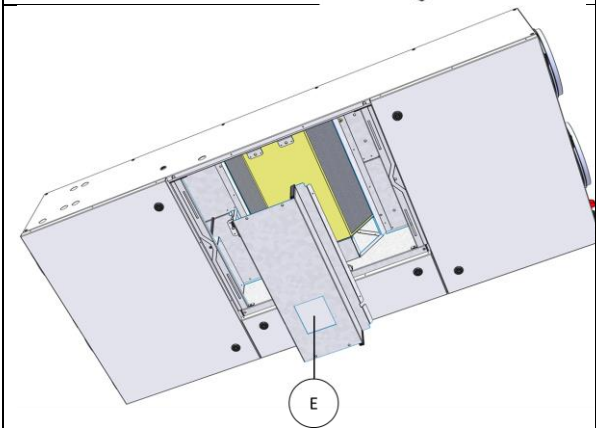

The exchanger can be cleaned by rinsing with clean water, if necessary using a spray. Allow sufficient time for drainage and drying to prevent water droplets from entering the supply air system.

FLATPOWER

Ceiling Energy Recovery Unit

XV.5. Removal and refitting of CO/DXR coil condensate tray

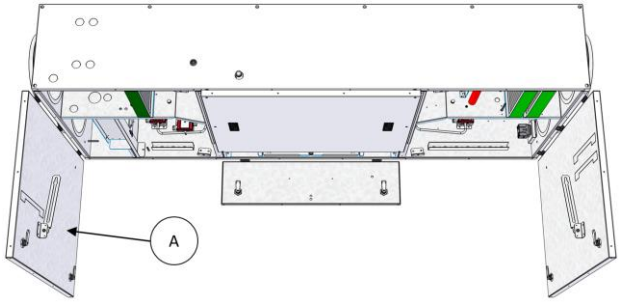
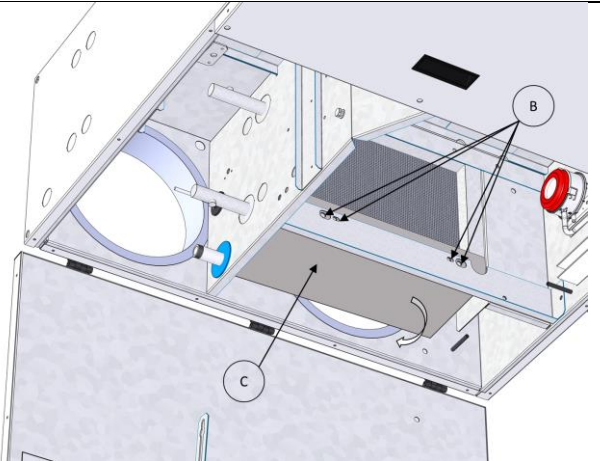
Step	Removal	
D1	Stop the unit and cut off the power supply using the isolator switch on the side of the unit.	
D2	Open the door (A) to access the coil.	
D3	Remove the condensate drain device connected to the condensate tray.	
D4	Remove the screws (B) (M6 hex head) from the condensate tray bracket while supporting the tray.	
D5	Remove the tray (C) by rotating and sliding it down. The maximum weight of the condensate tray is lower than 10kg on all units.	
Step	Refitting	
R1	Proceed in reverse order to the removal process.	
R2	Fill the condensate drip tray with water to fill the siphon (if gravity drain).	
R3	Observe the sealing at the connection between the condensate tray connection and the siphon pipework. Check the proper working of the condensate lift pump if present.	
R4	When closing the door, re-engage the opening tie rod.	
R5	Start the machine. Check that there is no abnormal noise and that the performance and setpoints (pressure, volume flow, temperature, etc. depending on the version) are achieved.	

The condensate tray can be cleaned and disinfected by soaking and rinsing with clean water, if necessary with bleach.

XVI. TROUBLESHOOTING - MAINTENANCE

When the ventilation unit is malfunctioning, it is recommended that you first:

- Check the tightness and connection of the terminal blocks and electrical plugs/connectors,
- Check the setting and consistency of the control parameters and setpoints,
- Check the presence and operation of a remote BMS.

XVI.1. Connection and setting of the filter control pressure switch

Pressure switches for monitoring the clogging of filters allow the degree of clogging in filters to be checked by measuring the pressure drop between the inlet (upstream) and the outlet (downstream) of the filter. When the pressure drop (pressure difference) of the filter element exceeds the setting of the pressure switch, the NO contact of the pressure switch closes. The factory setting of the filter pressure switch is 150 Pa for M5 filters and 200 Pa for F7 filters.

If an additional filter is installed for the intake air (double filter stage) in addition to the standard filter, the pressure switch must be set to 300 Pa.

Tube (+) is connected to the pressure taps upstream of the filter, tube (-) is connected downstream of the filter.

Refer to the wiring diagram for details on the electrical connection of the pressure switch.

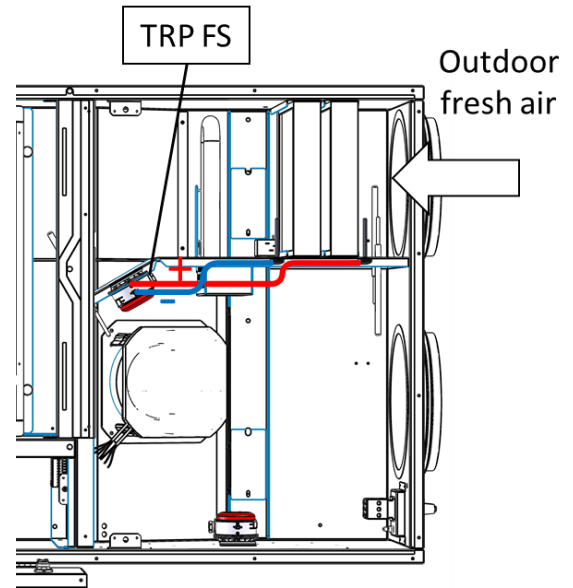

XVI.2. Connection and setting of the fan feedback pressure switches (ECO and DIVA versions)

The fan feedback pressure switches check at any time the pressure difference between fan inlet and outlet. This pressure difference indicates whether the fan is working properly or not.

FLATPOWER 600-900

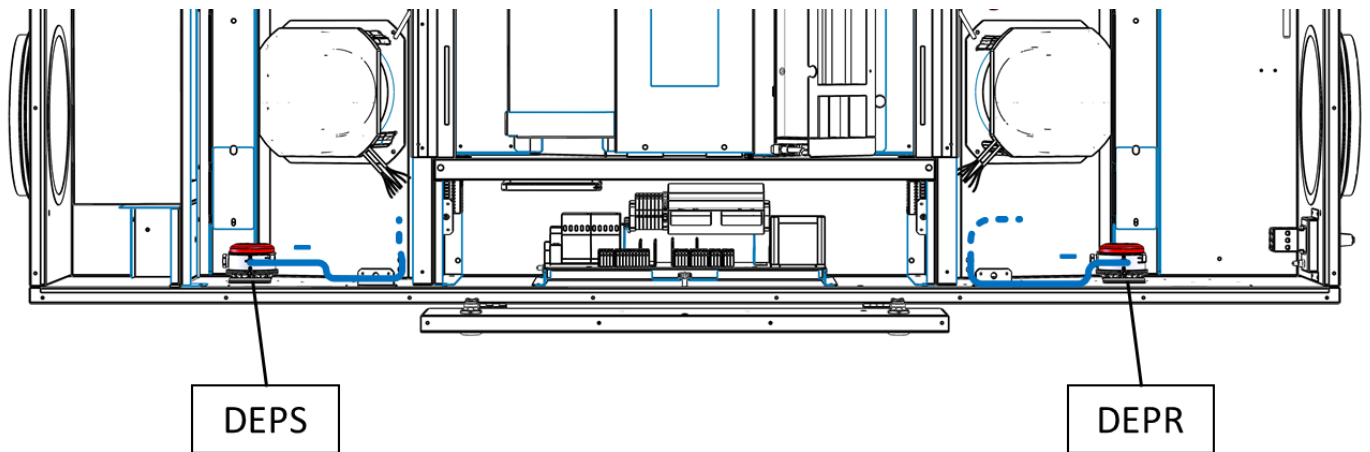

Tube (-) is connected upstream of the fan. There is no tube (+).

FLATPOWER 1300-1800-2500

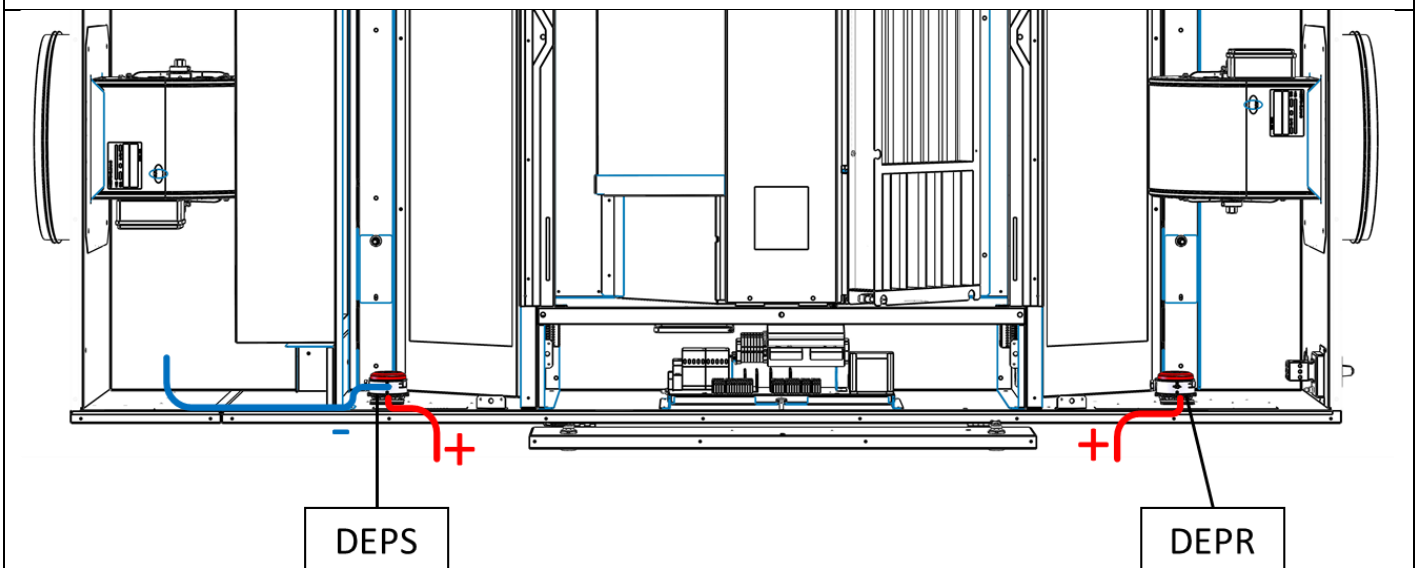

Tubes (+) are in relation with the outside of the unit (atmospheric pressure).
On DEPS, tube (-) is connected to the fan compartment. There is no tube (-) on DEPR.

The factory setting for the pressure switches is 25 Pa.

Refer to the wiring diagram for details on the electrical connection of the pressure switches.

XVI.3. Connection and setting of the pressure transducers (LOBBY)

The pressure transducers convert the relative air pressure measured at the air supply and extract of the unit into an analogue 0-10V signal which is transmitted to the controller.

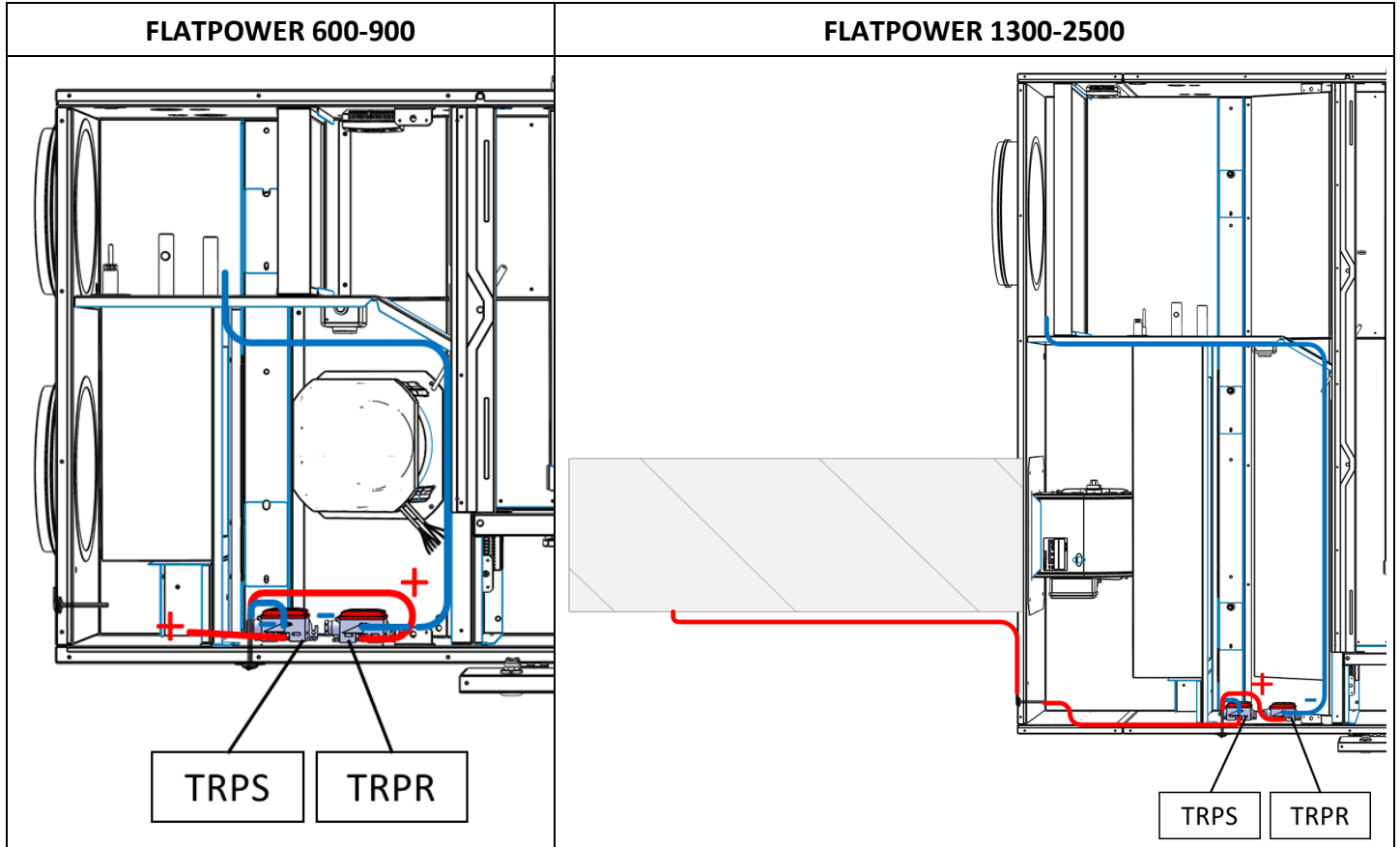

Tube (-) on TRPS and tube (+) on TRPR are connected to the outside of the unit (atmospheric pressure)

Pressure transducers cannot be adjusted. The signal is also used by the controller to check that the fans are working properly. The threshold is 25 Pa.

The factory setpoint is 130 Pa.

Refer to the wiring diagram (see XVII.3 Control wiring diagram – Pressure transducers and CO2) for details of the electrical connection of the pressure transducers.

FLATPOWER LOBBY		Setting the position of the pressure transducer dip switches
Range	600...2500	
TRPS	0-1600Pa / 0-10V	<p style="text-align: center;">ON</p> <p style="text-align: center;">The dip switches are in the OFF position (position 0)</p>
TRPR		

XVI.4. Connection of pressure transducers (MAC2)

The pressure transducers convert the differential air pressure measured into an analogue 0-10V signal, which is transmitted to the controller. This signal is then converted by the controller into a volume signal.

FLATPOWER 600 - 900

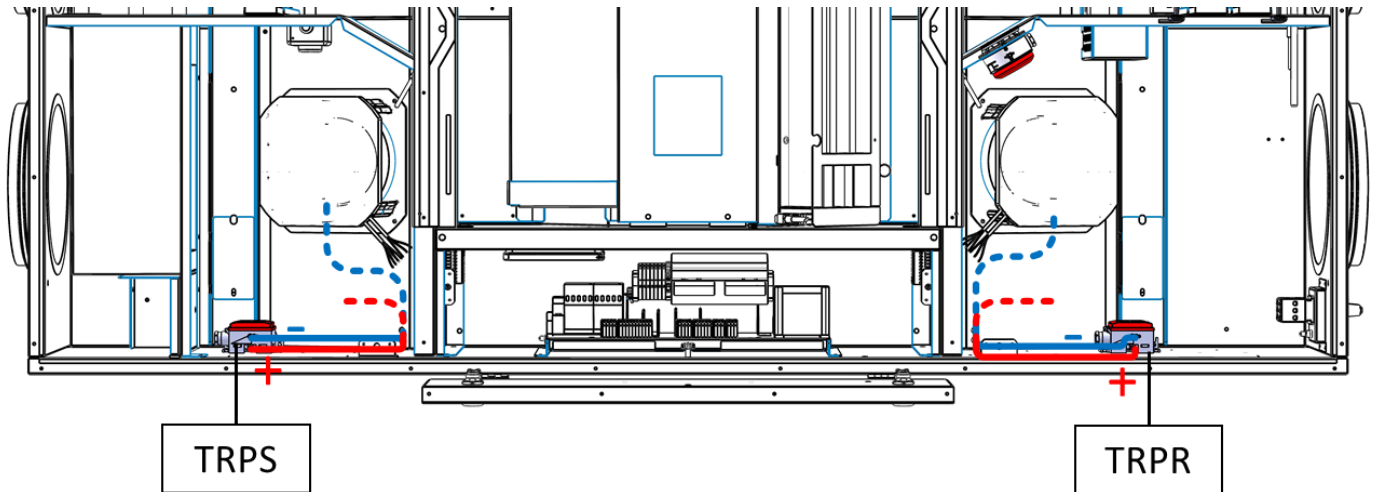

Tube (-) is connected is connected to a specific tap directly on the fan.
Tube (+) is connected to the compartment upstream of the fan.

FLATPOWER 1300 – 1800 - 2500

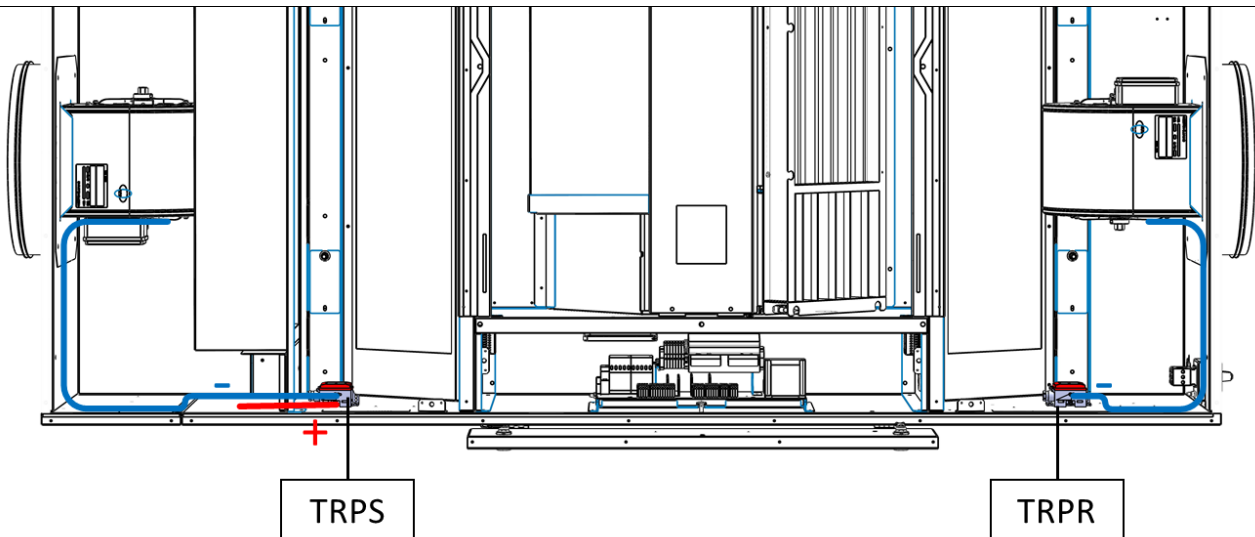

Tube (-) is connected is connected to a specific tap directly on the fan.
On TRPS, tube (+) is connected into the fan compartment. There is no tube (+) on TRPR.

FLATPOWER

Ceiling Energy Recovery Unit

The signal is also used by the controller to check that the fans are working properly (run and deviation monitoring). The threshold is different for each unit model:

Unit (MAC2)	Reduced operation volume (m3/h)	Normal operation volume (m3/h)	Operat. feedback threshold Supply + extract fans (m3/h)	Deviation threshold Supply + extract fans (m3/h)
600	250	500	155	150
900	350	700	225	210
1300	550	1100	500	330
1800	750	1500	550	450
2500	1000	2000	650	600

Refer to the wiring diagram (see XVII.3 Control wiring diagram – Pressure transducers and CO2) for details of the electrical connection of the pressure transducers.

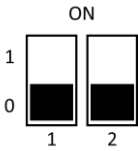
Range	FLATPOWER MAC2		Setting the position of the pressure transducer dip switches
	600	900...2500	
TRPS	0-1600Pa / 0-10V	0-300Pa / 0-10V	<div style="text-align: center;">  <p>The dip switches are in the OFF position (position 0)</p> </div>
TRPR			

XVI.5. Overheating safety thermostats THS and THSD

When overheating has been detected by the overheating safety thermostats THS or THSD, it is necessary to reset them by pressing the white reset knob after removing the protective cap screwed on the thermostat body itself.

Before resetting the thermostat, it is necessary to know the cause of the overheating and to remedy it in order to avoid any damage to the equipment. There may be overheating of the electric coil, for example, due to a faulty solid-state relay and/or fan, or due to a power failure when the coil was at full power (check for alarms).

The bulbs of the overheating safety thermostats are placed directly:

- On the electric heating coil (BE) for the THS
- On the frost protection coil for the THSD.

FLATPOWER

Ceiling Energy Recovery Unit

THSD

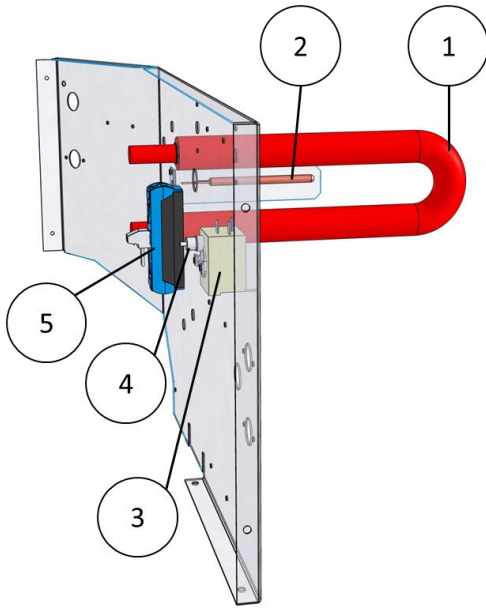

THS

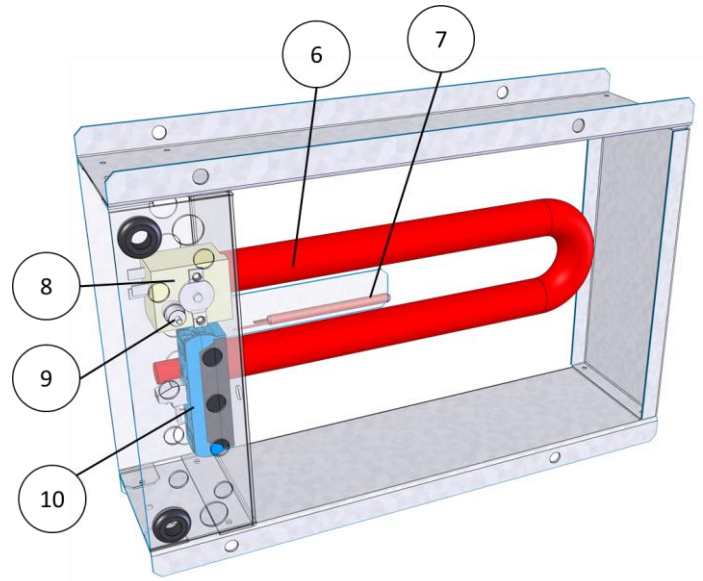

- (1) Heater
- (2) Bulb of overheating safety thermostat THSD
- (3) Body of overheating safety thermostat THSD
- (4) Knob for manual reset of the thermostat THSD
- (5) Solid State Relais KSD (KSD/KSD1/KSD2)

- (6) Heater
- (7) Bulb of overheating safety thermostat THS
- (8) Body of overheating safety thermostat THS
- (9) Knob for manual reset of the thermostat THS
- (10) Solid State Relais KS (KS/KS1/KS2)

XVI.6. Frost protection thermostat THA

The frost protection thermostat THA is located in the CO coil compartment integrated to the unit. The bulb is located immediately downstream of the CO coil.

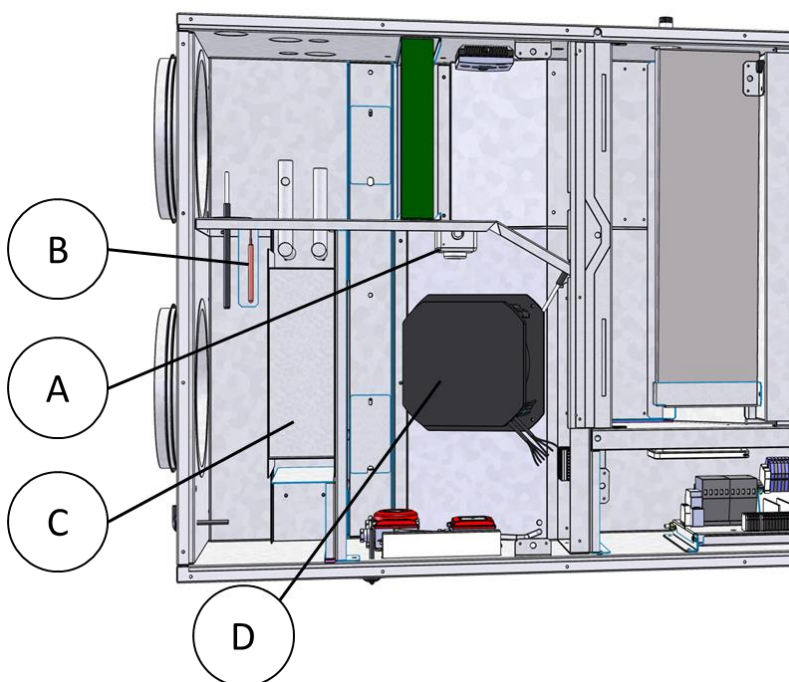

- (A) Frost protect. Thermostat THA
- (B) Bulb of thermostat THA
- (C) Changeover coil CO
- (D) Supply air fan VAS

XVI.7. Replacing the internal memory battery

The appearance of the low battery alarm (alarm #78) indicates that the battery powering the internal memory and Real Time Clock (RTC) is too low and may fail to operate in the event of a power failure. The procedure for replacing the battery is described below. A condenser takes over when the battery is removed. The battery should be replaced within approximately 10 minutes after the power supply is cut off. If the battery replacement takes less than 10 minutes, it will not be necessary to reload the programme and the clock will continue to operate normally. If necessary, the controller must be reprogrammed.

It is a CR2032 battery.

Press the clips on either side of the housing with a small screwdriver to release the cover from the base. Hold the base and remove the cover.

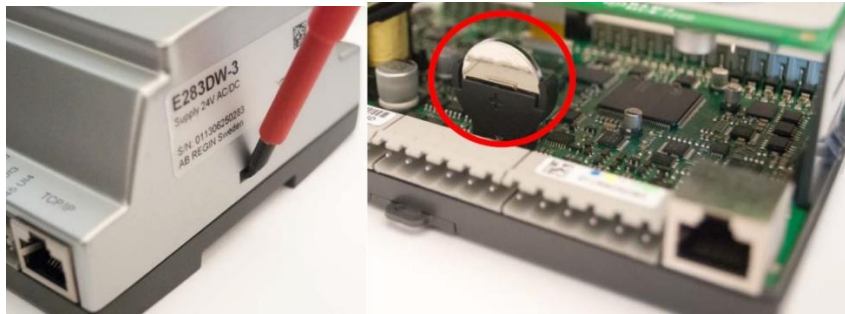

Hold the battery and gently pull it upwards until it comes out of the battery holder. Replace the new battery by pressing firmly on it to slide it into its holder.

Note: Pay attention to the direction of the battery to ensure correct polarity.

XVII. WIRING DIAGRAMS

FLATPOWER

Ceiling Energy Recovery Unit

XVII.2. Power wiring diagram –400V AC 3-phases power supply

FLATPOWER	Versions					
	FIRST	SMART	PREMIUM BE	PREMIUM CO	INFINITE BE	INFINITE CO
1800					✓	
2500					✓	

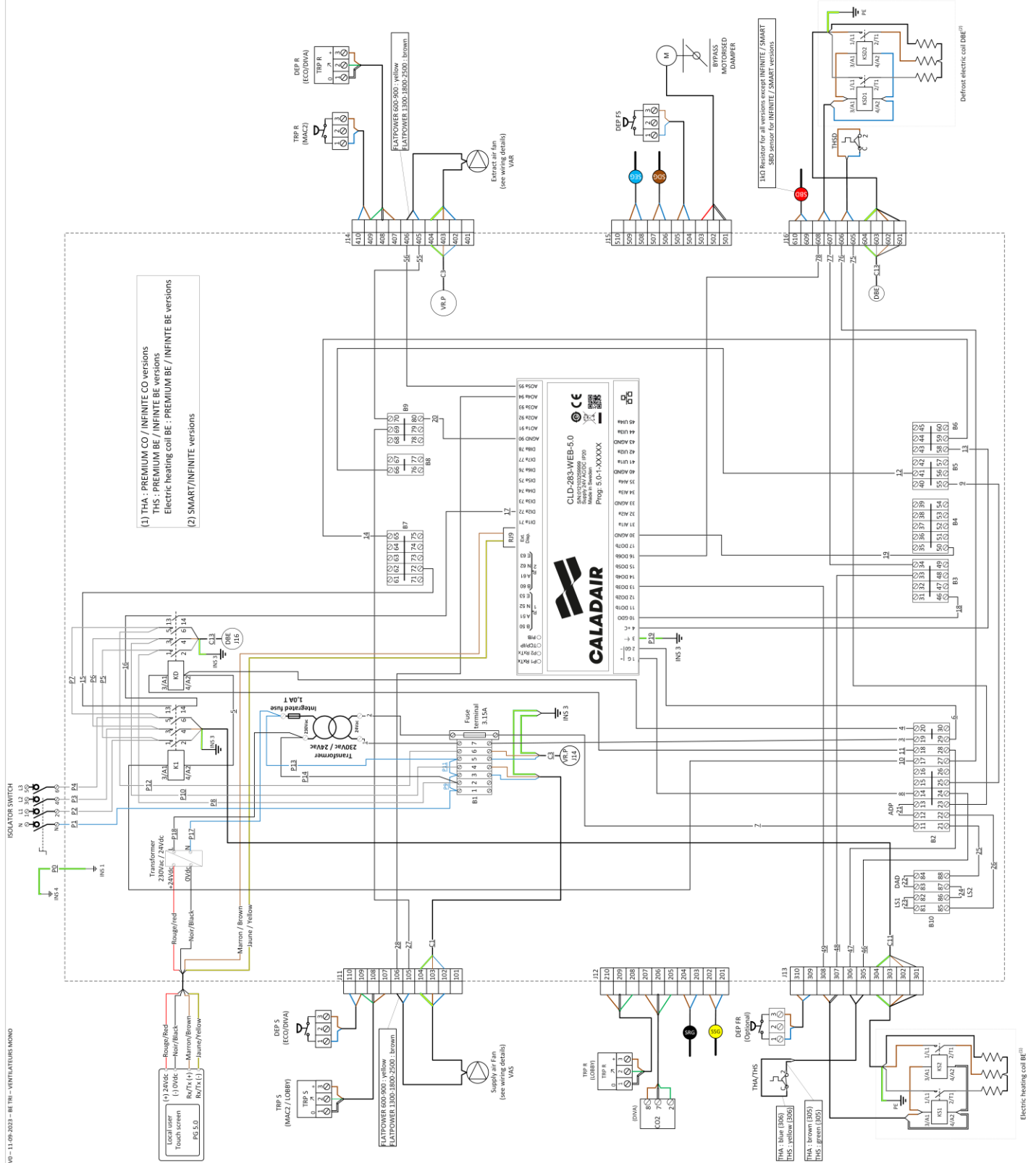

XVII.3. Control wiring diagram – Pressure transducers and CO2 sensor

All models

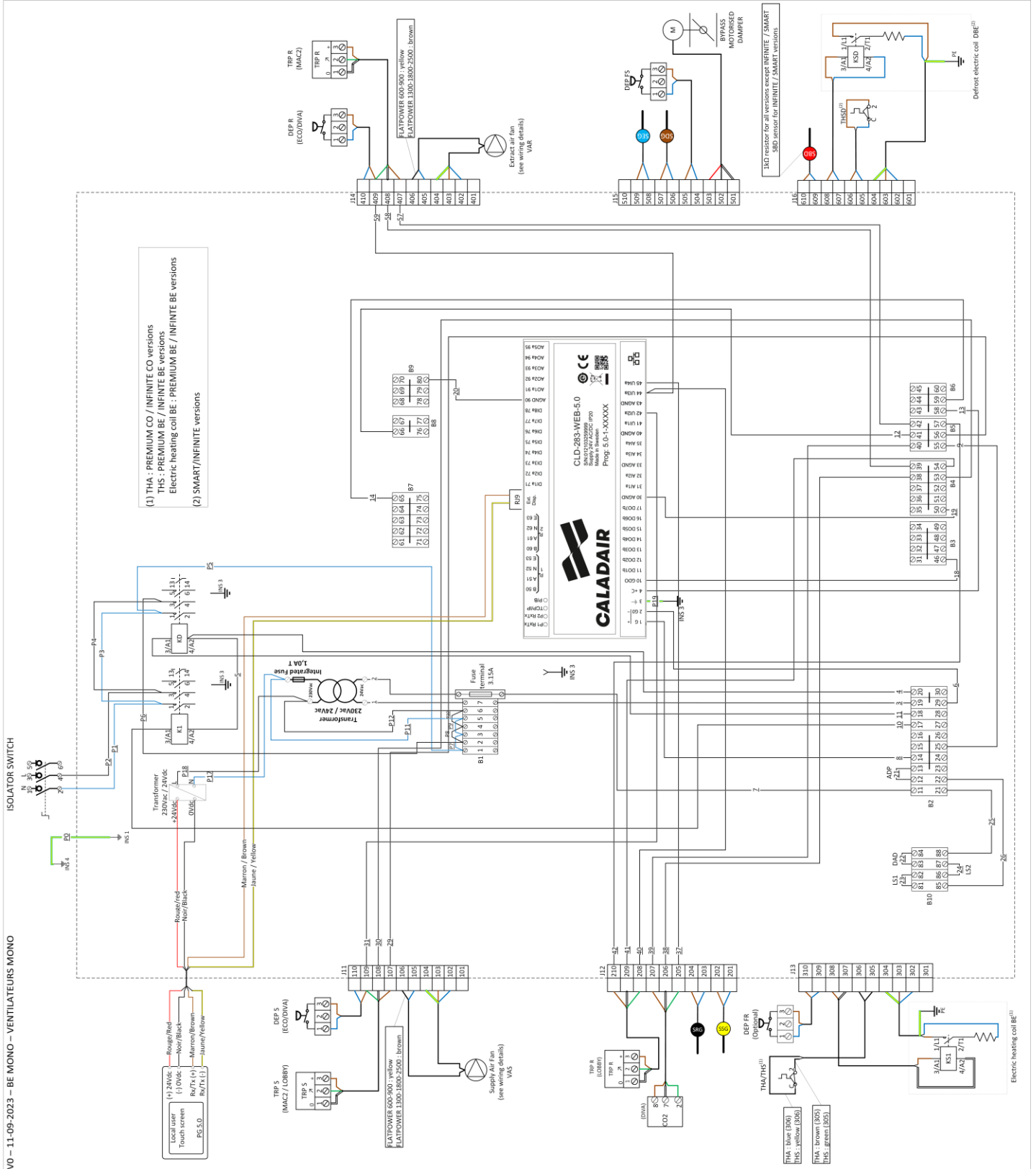

VO - 11-09-2023 - BE MONO - VENTILATEURS MONO

XVII.4. Control wiring diagram – Pressure switches and bypass damper actuator

All models

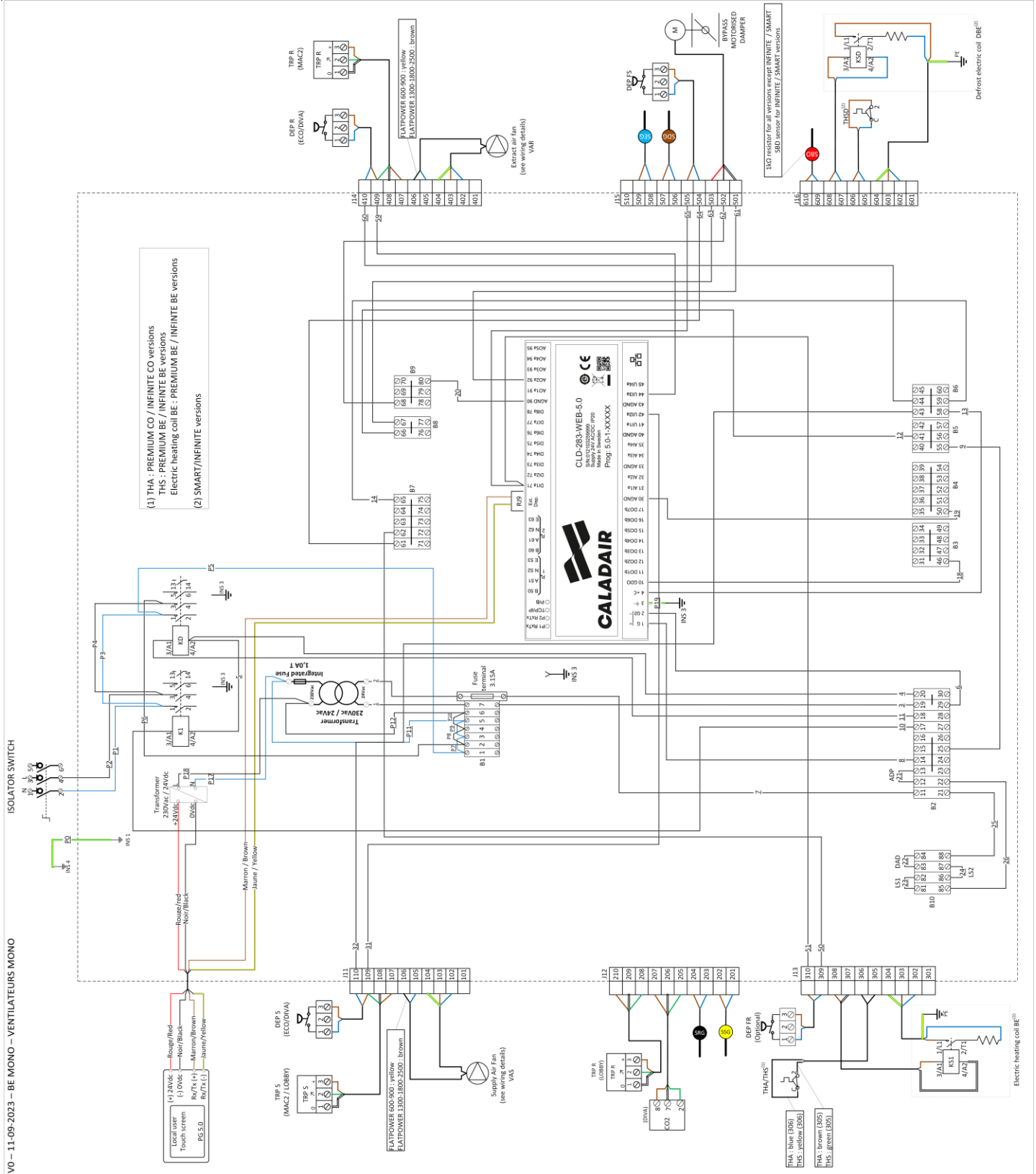

XVII.6. Wiring diagram - Fan motors

FLATPOWER 600 - 900

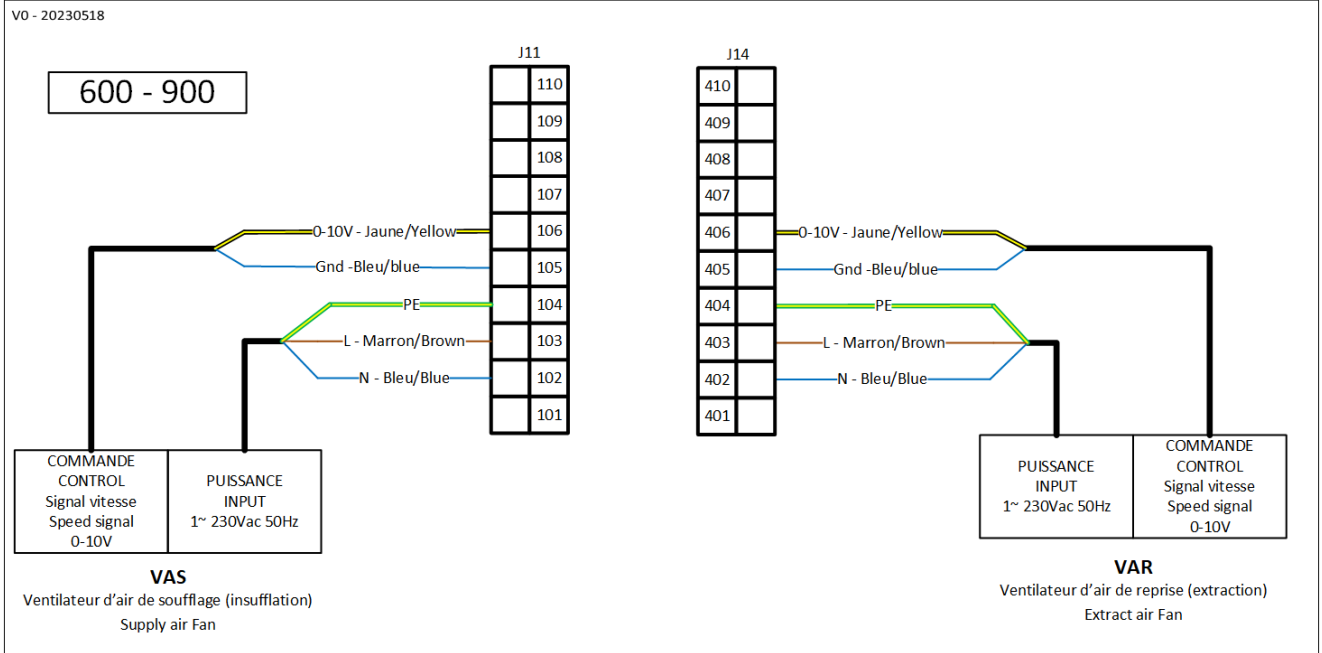

FLATPOWER 1300 - 1800 - 2500

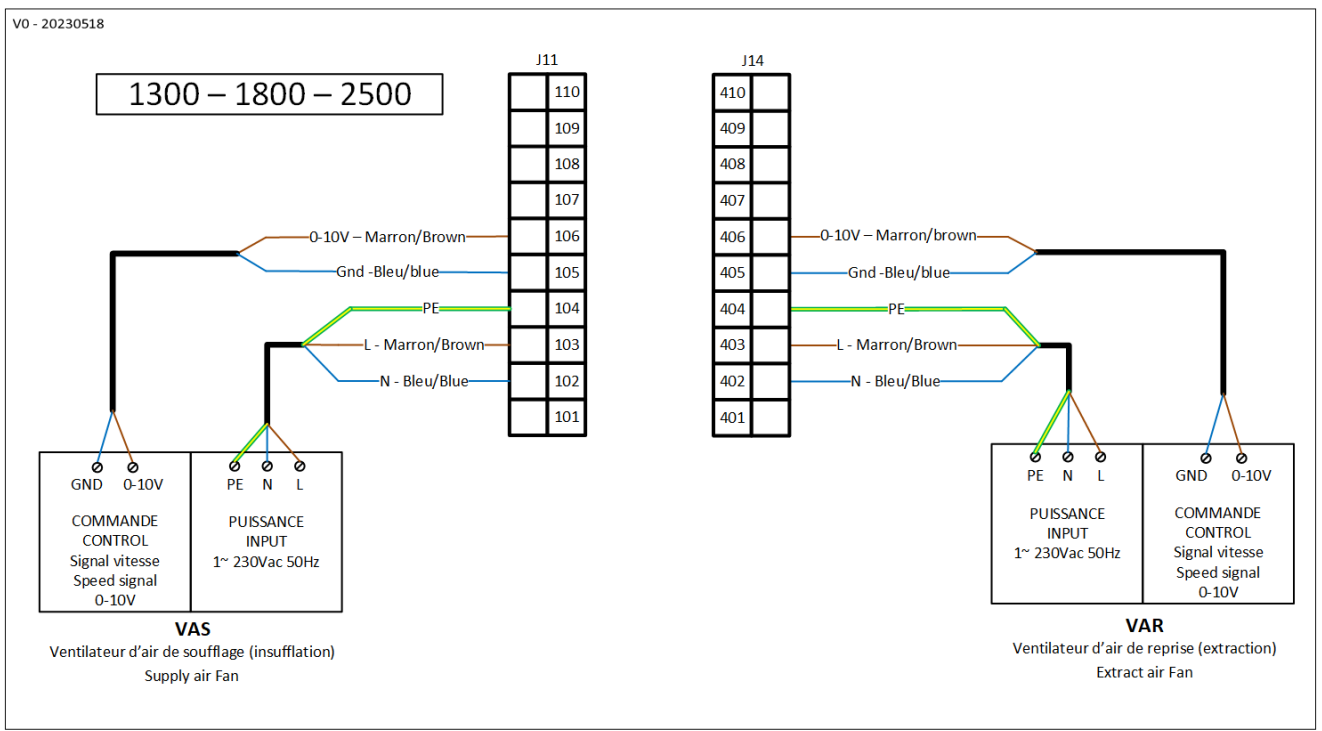

XVIII. GENERAL WIRING DIAGRAM OF OPTIONAL CUSTOMER'S EQUIPMENT

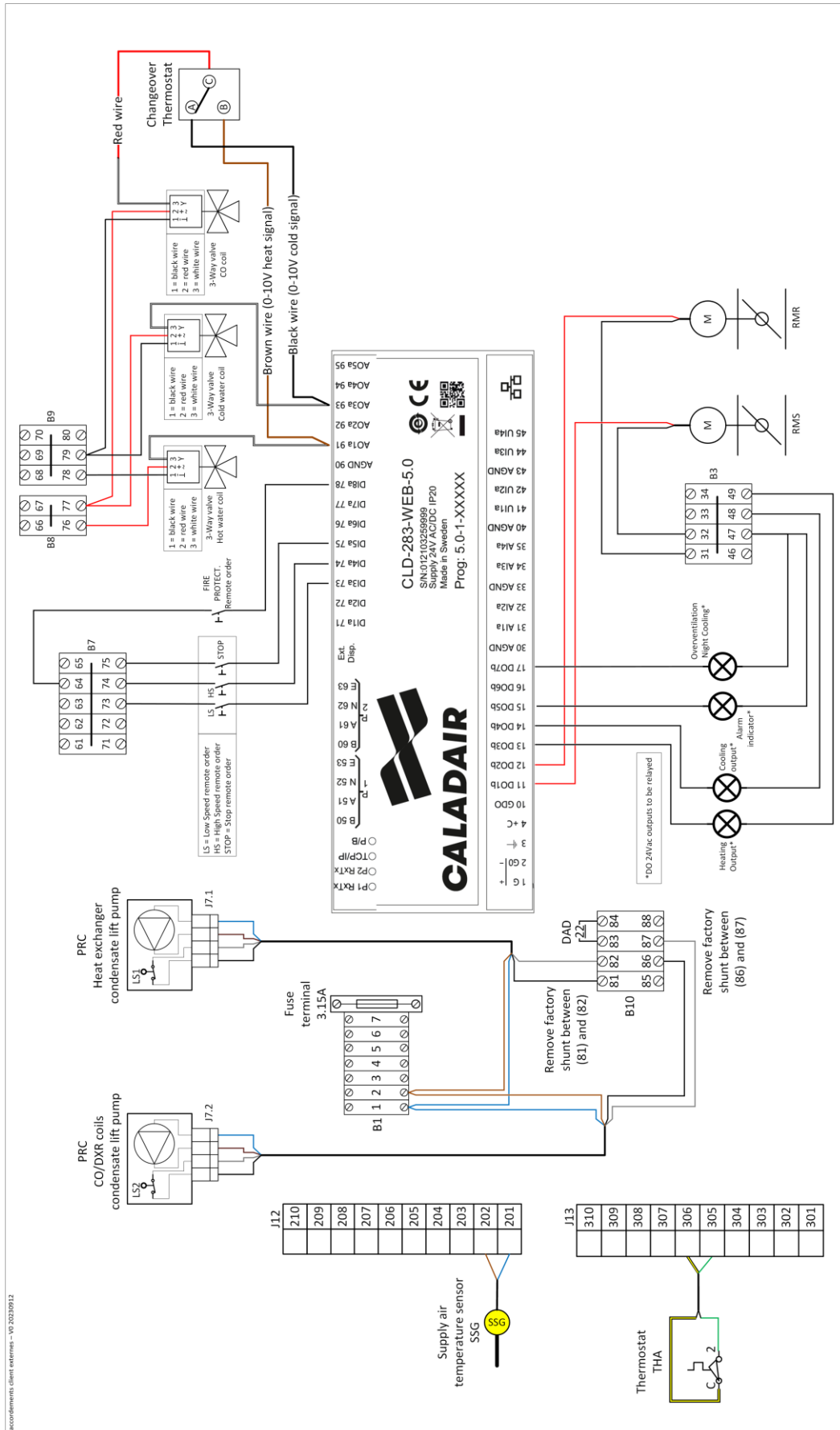

Recommandés client externes - VP 20230912

FLATPOWER

Ceiling Energy Recovery Unit

OPTIONAL EQUIPMENT (to be wired on site by the installer)

LS	Remote control of low-speed forced operation (reduced operation) by NO dry contact
HS	Remote control of high-speed forced operation (normal operation) by NO dry contact
STOP	Remote control of unit shutdown via NO dry contact
FIRE PROTECTION	Remote control of unit via NO dry contact to trigger the fire function
ADP	Remote firefighter stop by NC dry contact (B2 terminal block, not shown)
DAD	Autonomous trigger detector by NC dry contact
ALARM INDICATOR OUTPUT	Polarised 24V AC digital on/off output for alarm signal (to be relayed – 100mA max.)
OVERVENTILATION (NIGHT COOLING)	Polarised 24V AC digital on/off output for active night cooling signal (to be relayed – 100mA max.)
HEATING OUTPUT	Polarised 24V AC digital on/off output for active heating need (to be relayed – 100mA max.)
COOLING OUTPUT	Polarised 24V AC digital on/off output for active cooling need (to be relayed – 100mA max.)
RMS	Output for supply shutoff damper control (polarised at 24V AC)
RMR	Output for extract shutoff damper control (polarised at 24V AC)
3WV Hot water coil	0-10V control signal for the 3-way valve of the hot water heating coil (BC)
3WV Cold water coil	0-10V control signal for the 3-way valve of the cold water cooling coil (BF)
3WV CO coil	0-10V control signal for the 3-way valve of the changeover coil (CO)
HEAT EXCHANGER PRC + LS1	Power supply of the heat exchanger condensate lift pump with embed NC dry contact level switch LS1.
CO / DXR COILS PRC + LS2	Power supply of the CO/DXR coils condensate lift pump with embed NC dry contact level switch LS2.
Thermostat THA	Frost protection thermostat for remote cold-water coil
Supply air temperature sensor SSG	Remote supply air temperature sensor for remote coil
Changeover thermostat	Changeover thermostat for Changeover coil CO

XIX. EASY 5.0 CONTROL

Refer to specific manual MS-CDF-020 - Easy 5.0 controller.

XX. SEASON CONTROL

XX.1. General

The SEASON control is a simplified and streamlined solution for controlling the ventilation unit. In contrast to the Easy 5.0 control, it does not have an intelligent electronic controller, a local touch control PG 5.0 or a remote room touch control EDT2.

The SEASON control includes as standard:

- Individual fan speed setting via adjustable potentiometer,
- Heat recovery management by adjustable thermostat, including the functions:
 - Frost protection of the heat exchanger by bypassing the fresh (outdoor) air flow
 - Cold and heat recovery
- Fan operation feedback via pressure switch (NO/NC dry contacts)
- Clogging filters monitoring with pressure switches (NO/NC dry contacts).

The SEASON control does not allow the management of heating or cooling coils.
The bypass damper operates in on/off mode.

XX.2. Overview and constitution

The overview and construction of the SEASON version is very similar to the basic ECO version. The differences are mainly in the electrical board and the control components (temperature sensors, controller).
The SEASON version does not embed coil.

The other components common to the standard range equipped with the Easy 5.0 control are presented in chapter VII.1 General overview of the unit

XX.3. Electrical compartments and user controls

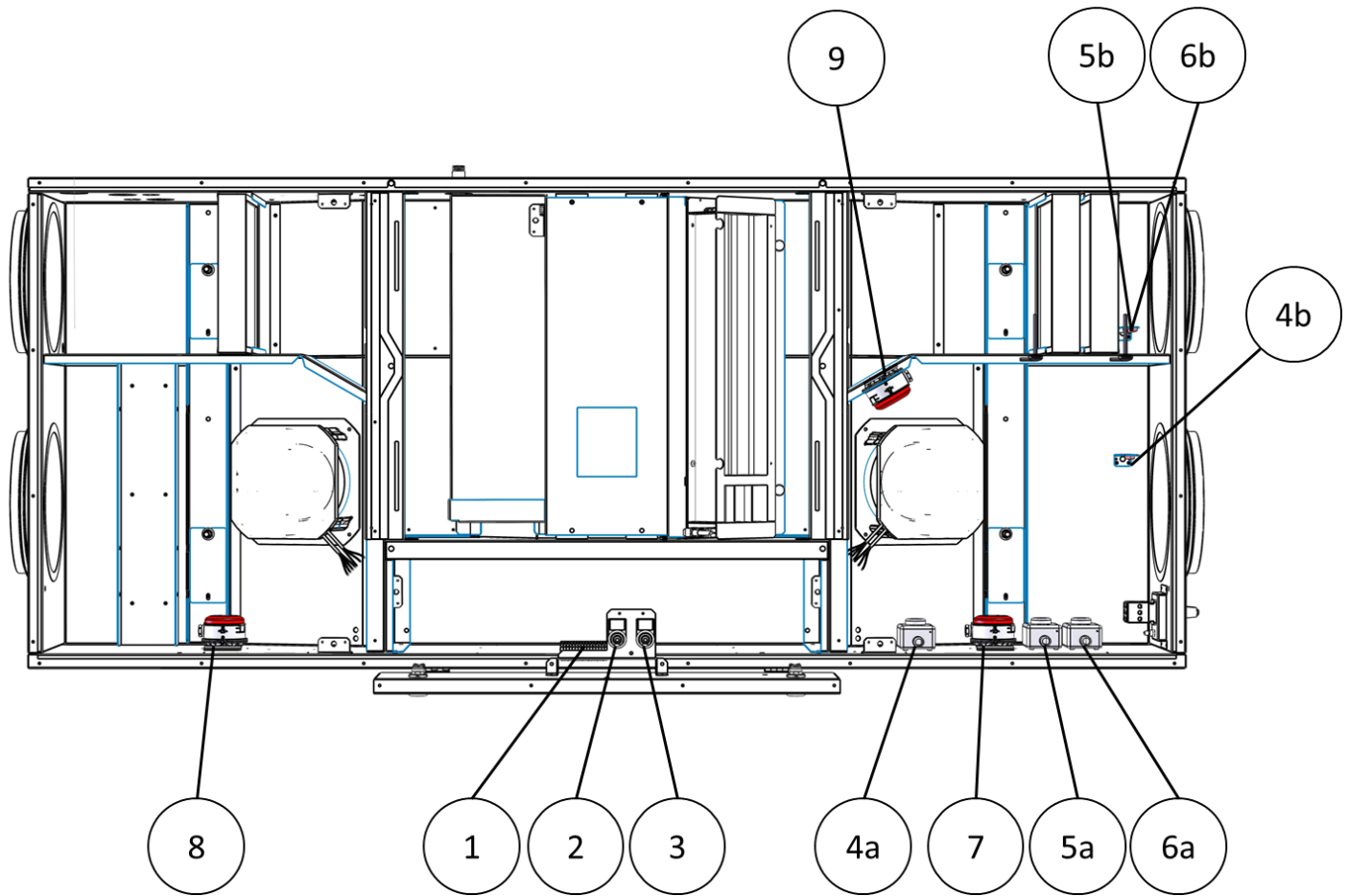

Mark	Name	Component
1		Electric terminal block
2	POT VAS	Speed setpoint potentiometers for supply air fan (VAS)
3	POT VAR	Speed setpoint potentiometers for extract air fan (VAR)
4a	TH3	Thermostat TH3 (frost protection)
4b	BTH3	Bulb of thermostat TH3
5a	TH2	Thermostat TH2 (cold recovery)
5b	BTH2	Bulb of thermostat TH2
6a	TH1	Thermostat TH1 (heat recovery)
6b	BTH1	Bulb of thermostat TH1
7	DEP R	Pressure switch for operation feedback of the extract air fan (VAR)
8	DEP S	Pressure switch for operation feedback of the supply air fan (VAS)
9	DEP FS	Pressure switch to monitor the clogging of the supply air filter

XX.4. General operating principle

When the power is switched on (isolating switch in ON position), the supply air fan and the extract air fan start after a few seconds to reach the set speed requested by the potentiometer position.

The bypass damper is activated when the power is switched on depending on the fresh (outdoor) air temperature, the exhaust temperature and the setting of the (adjustable) thermostats.

	Exhaust temperature***	Fresh (outdoor) air temperature**		
	< 5°C	< 18°C	18°C...24°C	> 24°C
Position du volet bypass*	Open	Closed (heat recovery)	Open	Closed (cold recovery)

*Open = the intake air flow does not pass through the exchanger / closed = the entire intake air flow passes through the exchanger

**Values for the factory settings of the thermostats to be adapted as required. Maintain a temperature difference of at least 6°C between the 2 thermostats.

***The thermostat placed at the exhaust (TH3) must be set at a temperature $\geq 5^{\circ}\text{C}$.

XX.5. User setting commands

XX.5.a. Thermostat TH1 (heat recovery)

The TH1 thermostat bulb is placed in the intake air flow (= outdoor temperature).

The factory setting of the thermostat is +18 °C:

Outdoor temperature < 18°C	Outdoor temperature > 18°C
Contact closed between terminals (C) and (1)	Contact open between terminals (C) and (1)

XX.5.b. Thermostat TH2 (cold recovery)

The TH2 thermostat bulb is placed in the intake air flow (= outdoor temperature).

The factory setting of the thermostat is +24 °C:

Outdoor temperature < 24°C	Outdoor temperature > 24°C
Contact open between terminals (C) and (2)	Contact closed between terminals (C) and (2)

XX.5.c. Thermostat TH3 (frost protection)

This thermostat ensures the frost protection function of the plate heat exchanger.

The bulb is placed in the exhaust air flow.

The factory setting of the thermostat is +5 °C:

Exhaust air temperature < 5°C	Exhaust air temperature > 5°C
Contact open between terminals (C) and (2)	Contact closed between terminals (C) and (2)

XX.6. Connecting and setting external user devices

At any time, the user can check the operating status of the fans and the state of clogging of the supply air filter through the use of 3 pressure switches:

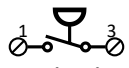
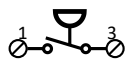
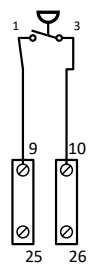
Device	Factory setting	Electrical connection to be made by the installer
Pressure switch for operation feedback of the supply air fan	25 Pa	<p style="text-align: center;">DEP S</p>  <p style="text-align: center;">The connection is to be made directly on the component.</p>
Pressure switch for operation feedback of the extract air fan	25 Pa	<p style="text-align: center;">DEP R</p>  <p style="text-align: center;">The connection is to be made directly on the component.</p>
Pressure switch for filter clogging	150 Pa for M5 filters 200Pa for F7 filters	<p style="text-align: center;">DEP FS</p>  <p style="text-align: center;">The connection is to be made between terminals (25) and (26).</p>

XX.7. Troubleshooting and maintenance

As the SEASON control system is very simple, the risk of breakdowns is relatively limited and confined to the main components.

Fault	Possible causes
The supply air fan is not working	<p>The 0-10V control signal potentiometer is in position 0 or is defective (control signal at the motor input below 1V).</p> <p>The 0-10V control signal wire is defective or the signal polarity is reversed.</p> <p>The power supply wiring is defective.</p> <p>The motor is defective.</p>
The extract air fan is not working	<p>The 0-10V control signal potentiometer is in position 0 or is defective (control signal at the motor input below 1V).</p> <p>The 0-10V control signal wire is defective or the signal polarity is reversed.</p> <p>The power supply wiring is defective.</p> <p>The motor is defective.</p>
The bypass damper is not working (the unit blows air at a temperature close to the outdoor temperature at low/high outdoor temperatures)	<p>The outdoor temperature is in the range where the bypass is inactive (normal case).</p> <p>Control thermostats TH1, TH2, TH3 are incorrectly set or defective.</p> <p>The actuator wiring is defective, the actuator is not powered.</p> <p>The actuator is defective.</p>

XX.8. General wiring diagram of the SEASON control system

XX.8.a. FLATPOWER SEASON 600-900

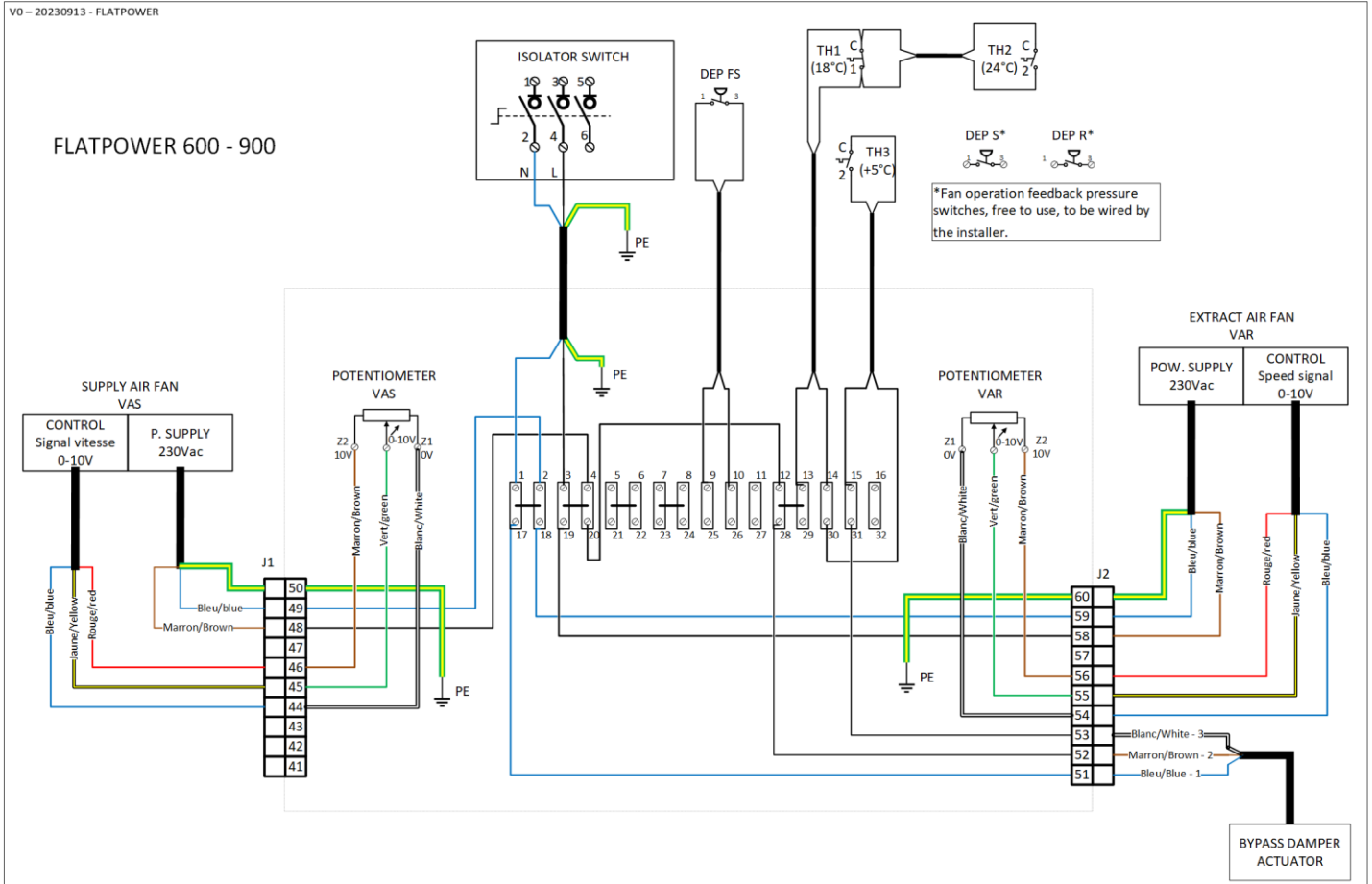

Note :

The power supply for the bypass actuator is provided between terminals (1) and (2) of the actuator. When the power is supplied and that:

- The potential is absent in terminal (3) of the actuator, the actuator is open, the air is diverted from the exchanger and there is no energy recovery,
- The potential is present at terminal (3) of the actuator, the actuator is closed, the air flows through the exchanger and energy recovery is active (100%).

XX.8.b. FLATPOWER SEASON 1300 – 1800 – 2500

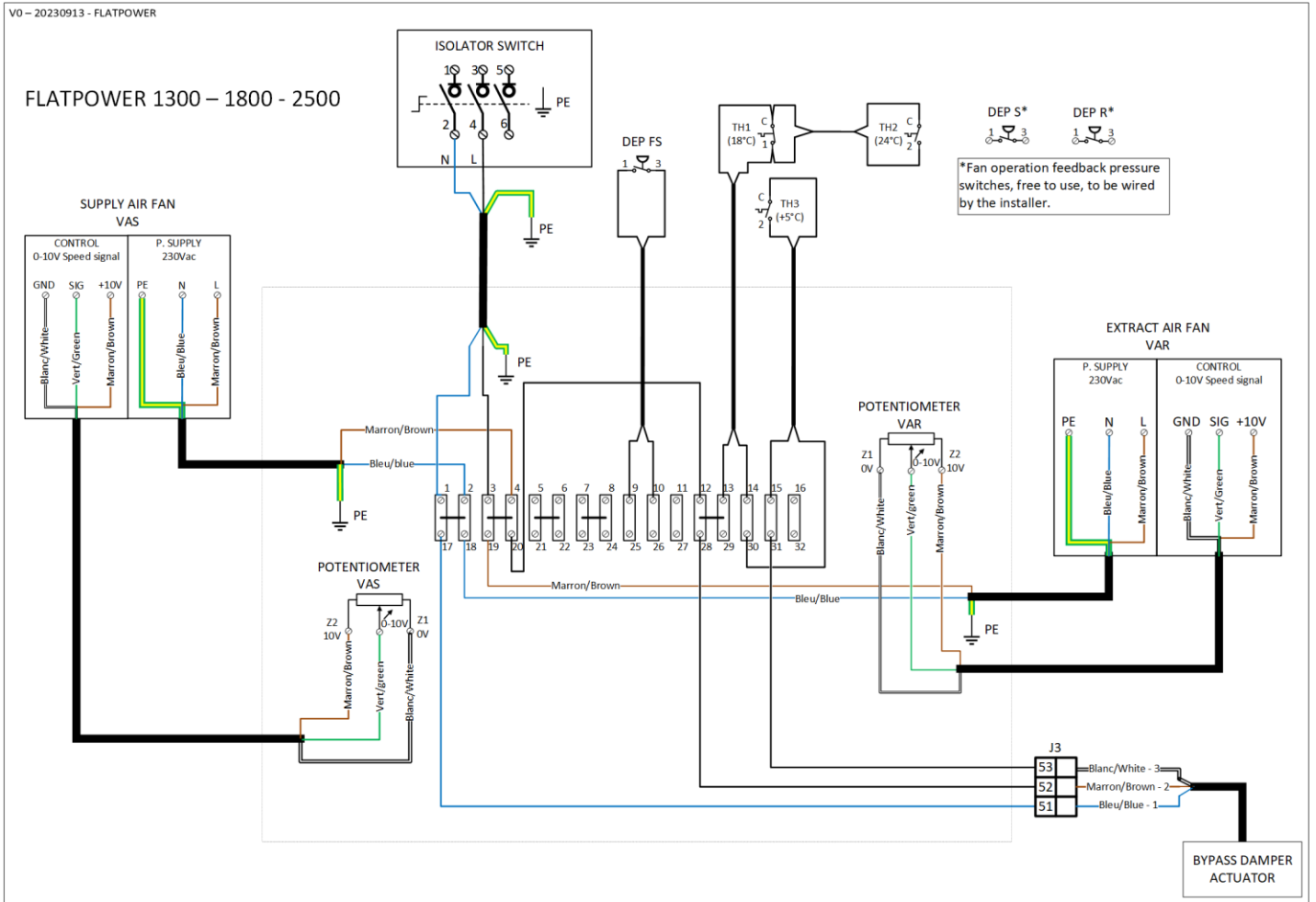

Note :

The power supply for the bypass actuator is provided between terminals (1) and (2) of the actuator. When the power is supplied and that:

- The potential is absent in terminal (3) of the actuator, the actuator is open, the air is diverted from the exchanger and there is no energy recovery,
- The potential is present at terminal (3) of the actuator, the actuator is closed, the air flows through the exchanger and energy recovery is active (100%).

XXI. AERAULIC PERFORMANCE CURVES

FLATPOWER 600

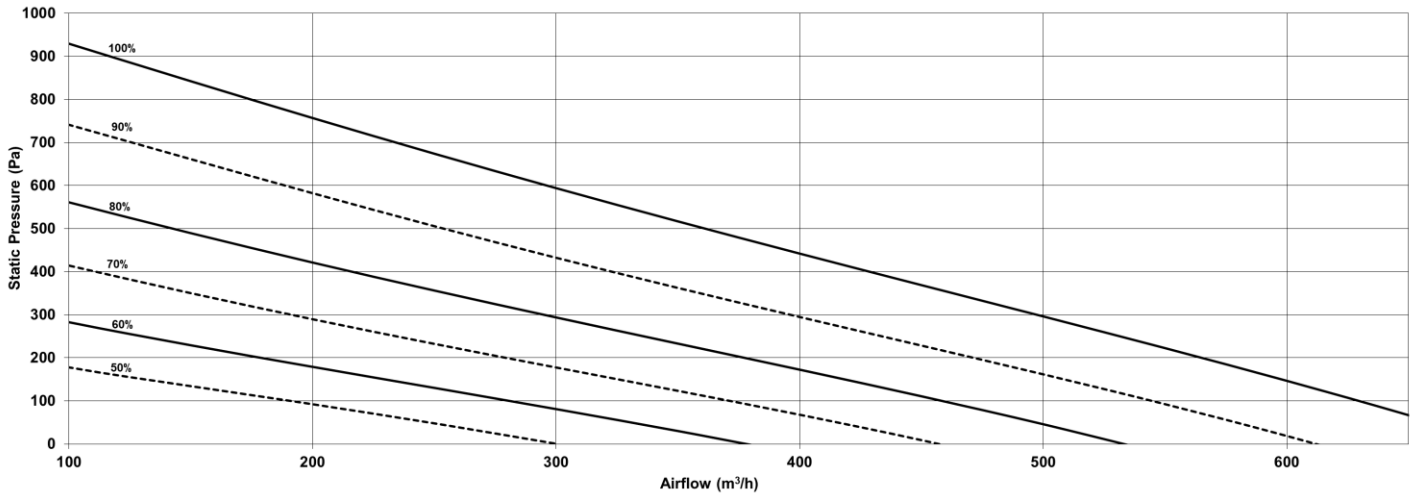

FLATPOWER 900

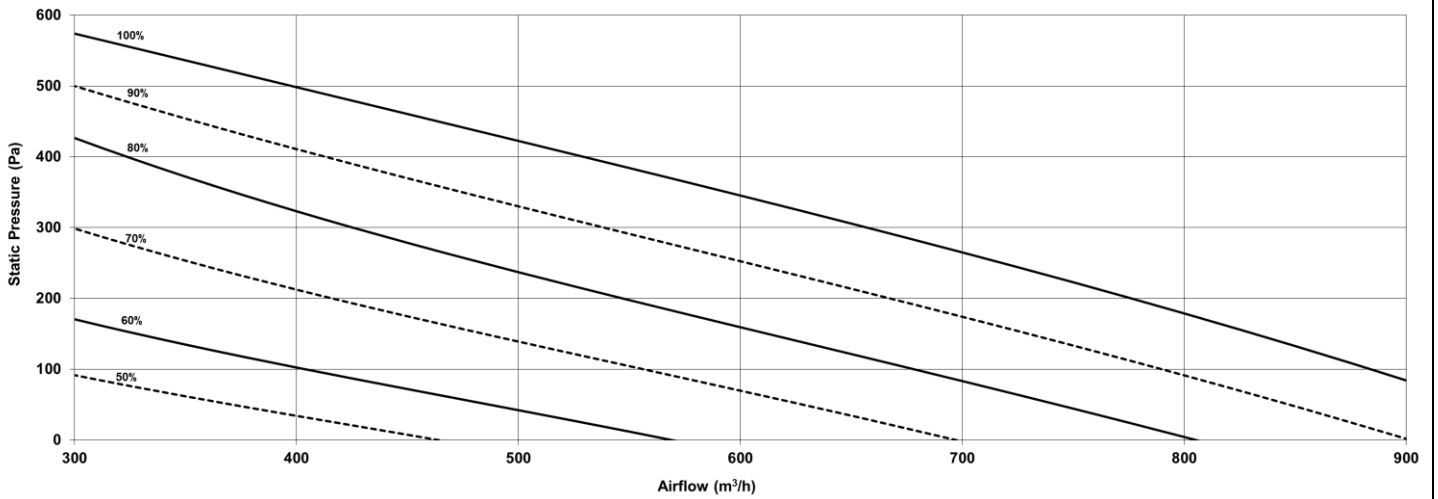

FLATPOWER 1300

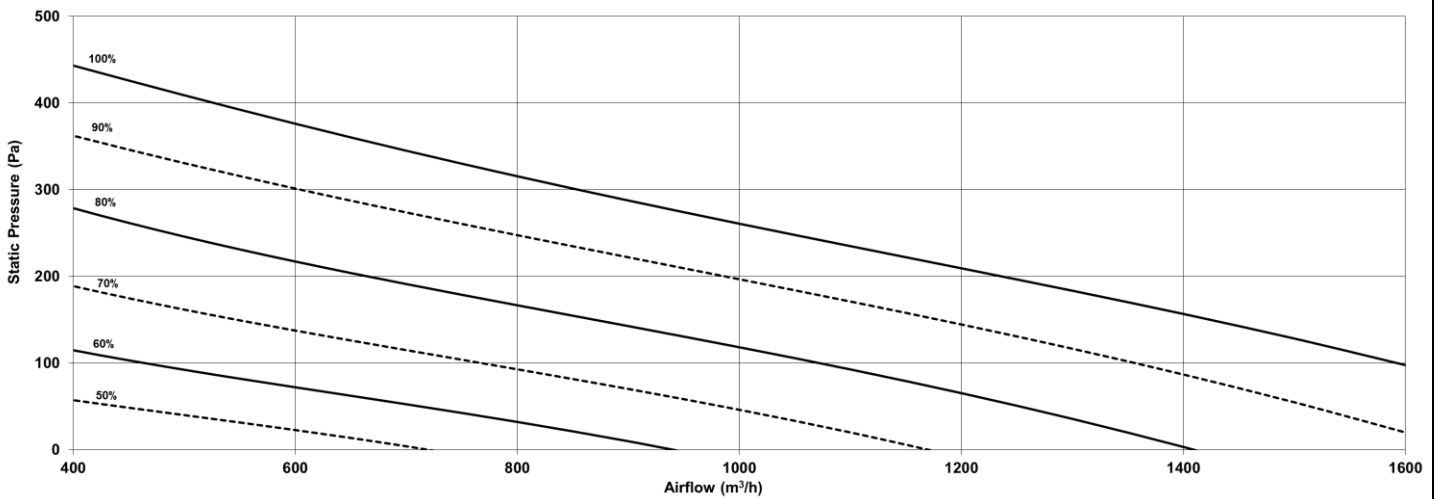

FLATPOWER

Ceiling Energy Recovery Unit

FLATPOWER 1800

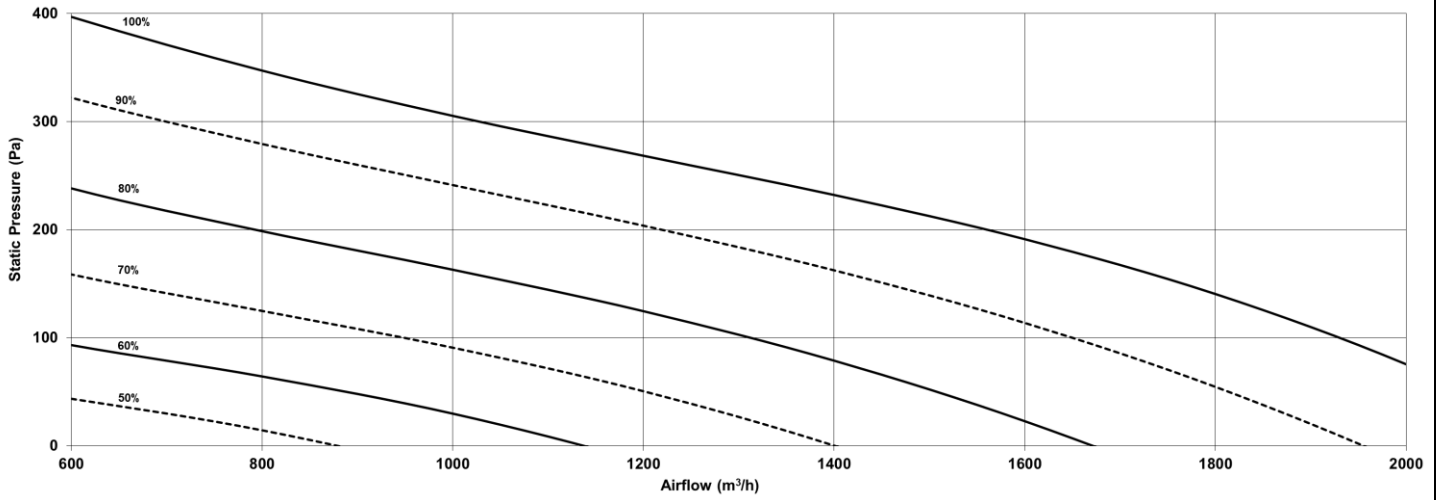

FLATPOWER 2500

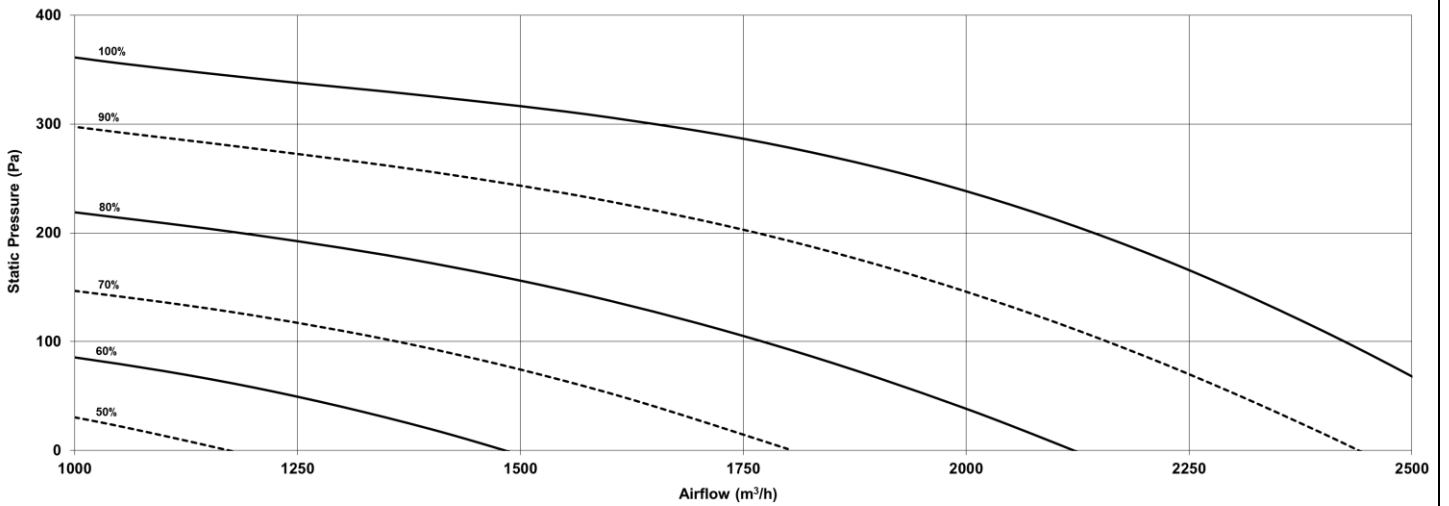

XXII. COMMISSIONING REPORT

Site			
Adress			
Date/...../.....	Technician / company	
Equipment reference			
Manufacturing number			
Version	FIRST / SMART PREMIUM BE / PREMIUM CO / PREMIUM DXR INFINITE BE / INFINITE CO / INFINITE DXR		
	ECO / LOBBY / MAC2 / DIVA		
Power supply voltage Vac		
Temperature control mode		Constant supply air temperature	
		Constant extract air temperature	
		Supply air temperature compensation	
		Extract air temperature compensation	
Temperature setpoints			
Ventilation setpoints	Supply	Reduced operation : % / Pa / m3/h	Normal operation: % / Pa / m3/h
	Extract	Reduced operation : % / Pa / m3/h	Normal operation: % / Pa / m3/h
CO2 setpoints (DIVA version)	Reduced operation: ppm	Normal operation: ppm	

Date	Stakeholder	Observations

FLATPOWER

Ceiling Energy Recovery Unit